

**Machine-Roomless  
Integrated Machine and  
Bedplate Structure  
(NSAA Passenger and Service  
Duties with Rear Counterweight)**

**Spare Parts Leaflet**

**06-AAA20238Y**

January 22, 2020 / Page 1 of 4

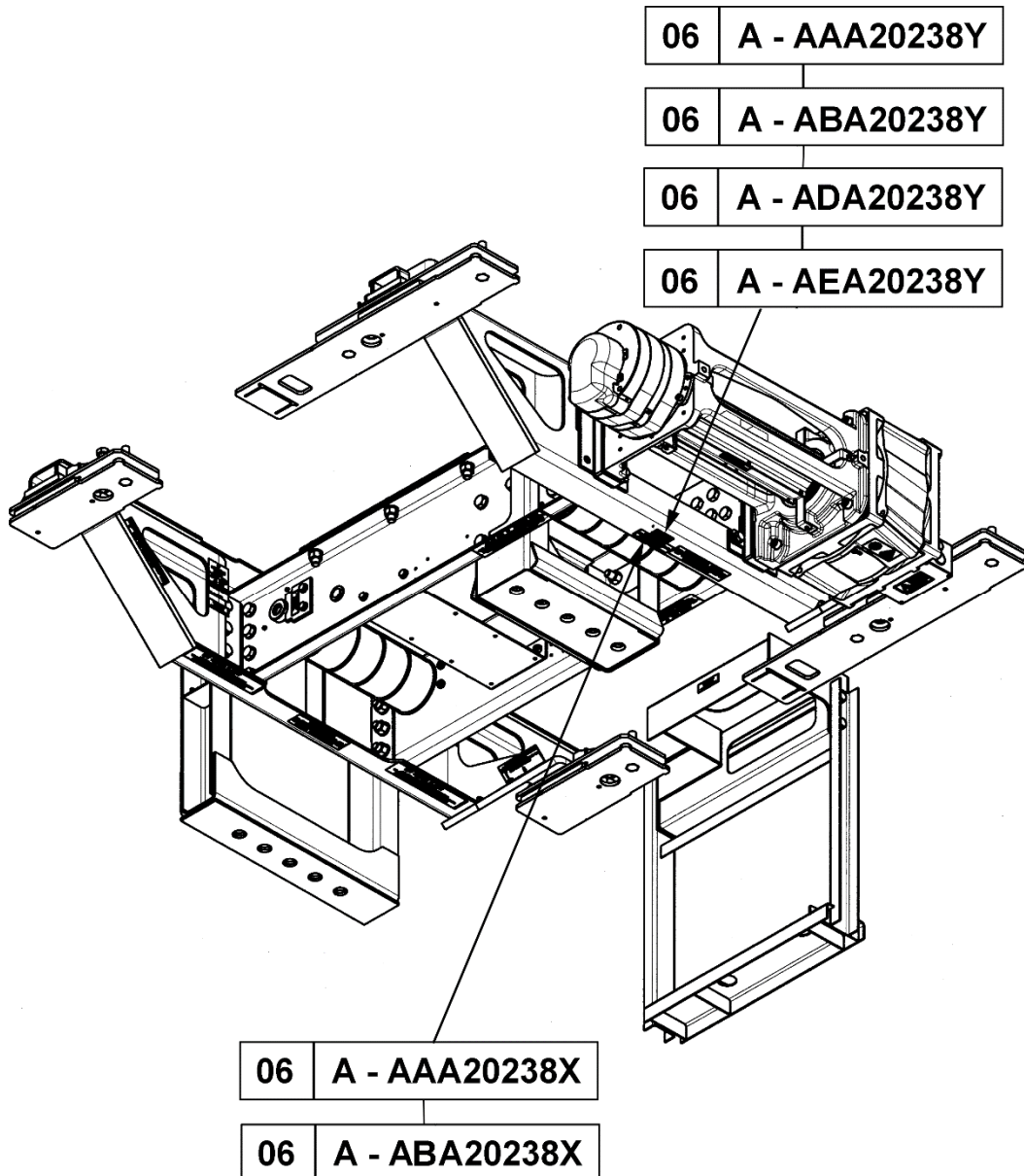

**OTIS**

This document does not contain any technical data subject to EAR or ITAR

**SERVICE ENGINEERING**  
**Otis Elevator Company**  
**Bloomfield, Connecticut USA**

Unpublished Work—© Otis Elevator Co.; 2020

**Leaflet Description**

This SPL lists the lowest replaceable units (LRUs) for the machine mounting structure used with NSAA hospital duties using a side counterweight and passenger duties with rear counterweights.

**Leaflet Revisions**

<b>Date Revised</b>	<b>Subject Matter Expert</b>	<b>Reason for Revision</b>
September 21, 2011	Richard Blakelock	New SPL
October 19, 2011	Richard Blakelock	Corrected callouts on p. 3
January 22, 2020	Gary Mendrala	Updated vintage information

**Related Drawings**

<b>Drawing No.</b>	<b>Title</b>	<b>Drawing No.</b>	<b>Title</b>
AAA20238X	Assembly, Machine Mounting Structure (MMS) for NSAA Extended Duties	AAA20780W	Sheave Assembly
ABA20238X		AEA20238Y	MMS Bedplate Assembly
AAA20780C	Sheave Assembly	AAA20220BG	Optimized Gen2 5.2T Machine ASME Series
AAA20220BE	Optimized Gen2 4.1T and 5.0T Machine ASME Series	AAA20780AS	Sheave Assembly

**Related Documents**

<b>Document ID</b>	<b>Title</b>
SPL 06-AAA20220AN	<i>Gen2® 5T AC Permanent Magnet Gearless Machine: ANSI-Compliant (Extended Duty &amp; Next Generation High Rise)</i>
SPL 06-AAA20220AS	<i>Gen2® 5T AC Gearless Machine: ANSI- and EN81-Compliant (regenerative drive)</i>
SPL 06-AAA20220BE	<i>Optimized Gen2 4.1T and 5.0T Machine ASME Series</i>
SPL 06-AAA20220BG	<i>Optimized Gen2 5.2T Machine ASME Series</i>
SPL 06-AAA20220AV	<i>AC Gearless Machine, 1.5 T &amp; 2.5 T (Regenerative)</i>

**Subject Matter Expert**

<b>Name</b>	<b>Department</b>
Gary Mendrala	OSC Service Engineering

**About Spare Parts Leaflets...**

This document lists the lowest replaceable units (LRUs) for the standard version of the product. The LRUs are chosen by a team of Otis associates representing engineering and manufacturing.

While goal of this document is to make parts identification as easy as possible, the document cannot be all-inclusive. Elevator and escalator contracts classified as "special" or "custom" are not addressed here. For such contracts, please refer to specified information, the contract folder, TIPs, Field Education Articles, Construction Letters, etc. for further information.

If you have any suggestions about this document, please contact the subject matter expert listed on this page.

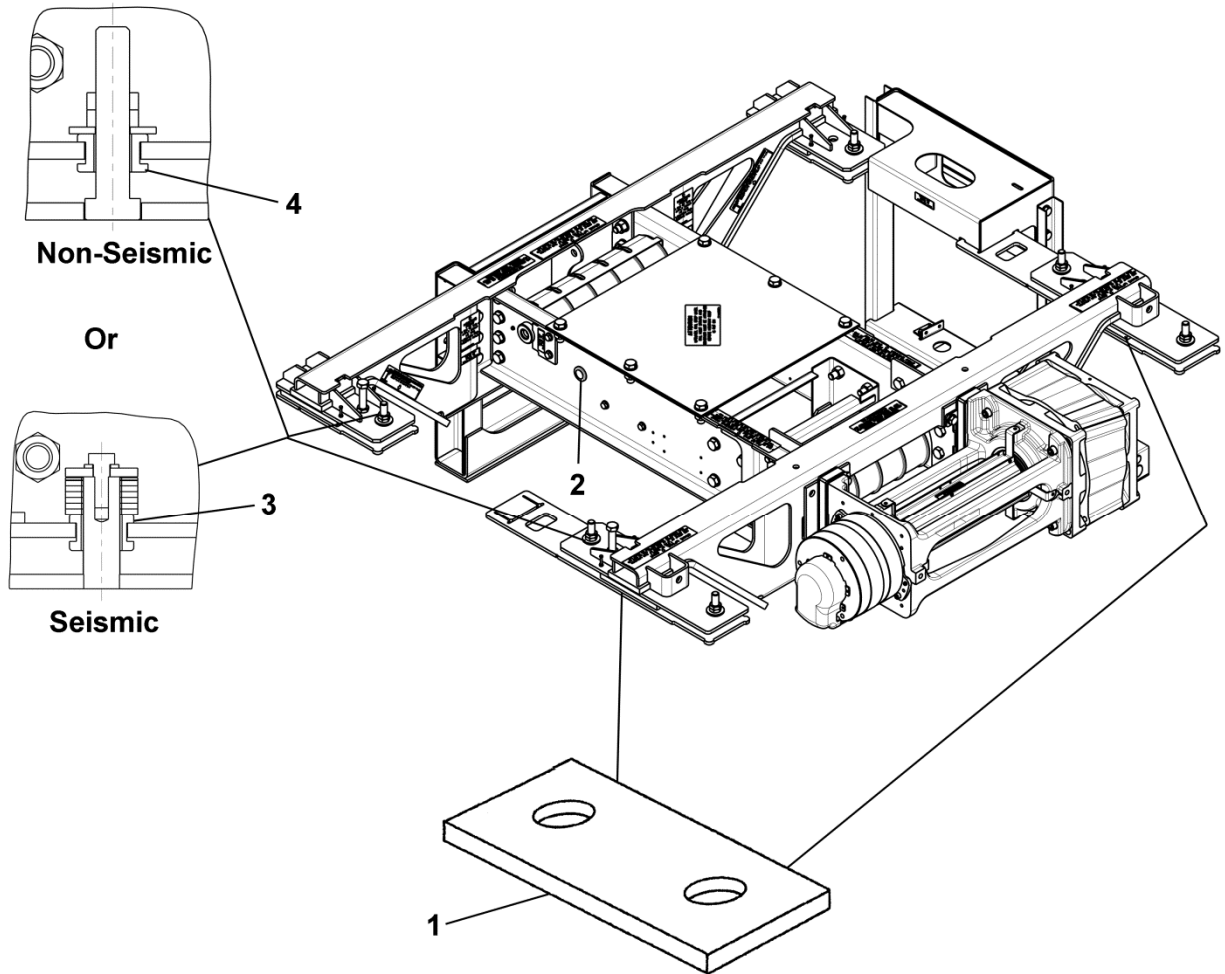

<b>AAA20238Y ABA20238Y</b>		
<b>REF. No.</b>	<b>PART No.</b>	<b>DESCRIPTION</b>
1	AAA310VT1	Block, Sound Isolation, 6 x 3 in.
2	334H42	Bushing, Rubber, 1.75 in. $\varnothing$ , 1.0 in. Wide
3	334H43	Bushing, Rubber, 2.5625 in. $\varnothing$ , 0.875 in. Wide
4	334H44	Bushing, Rubber, 1.625 in. $\varnothing$ , 0.875 in. Wide

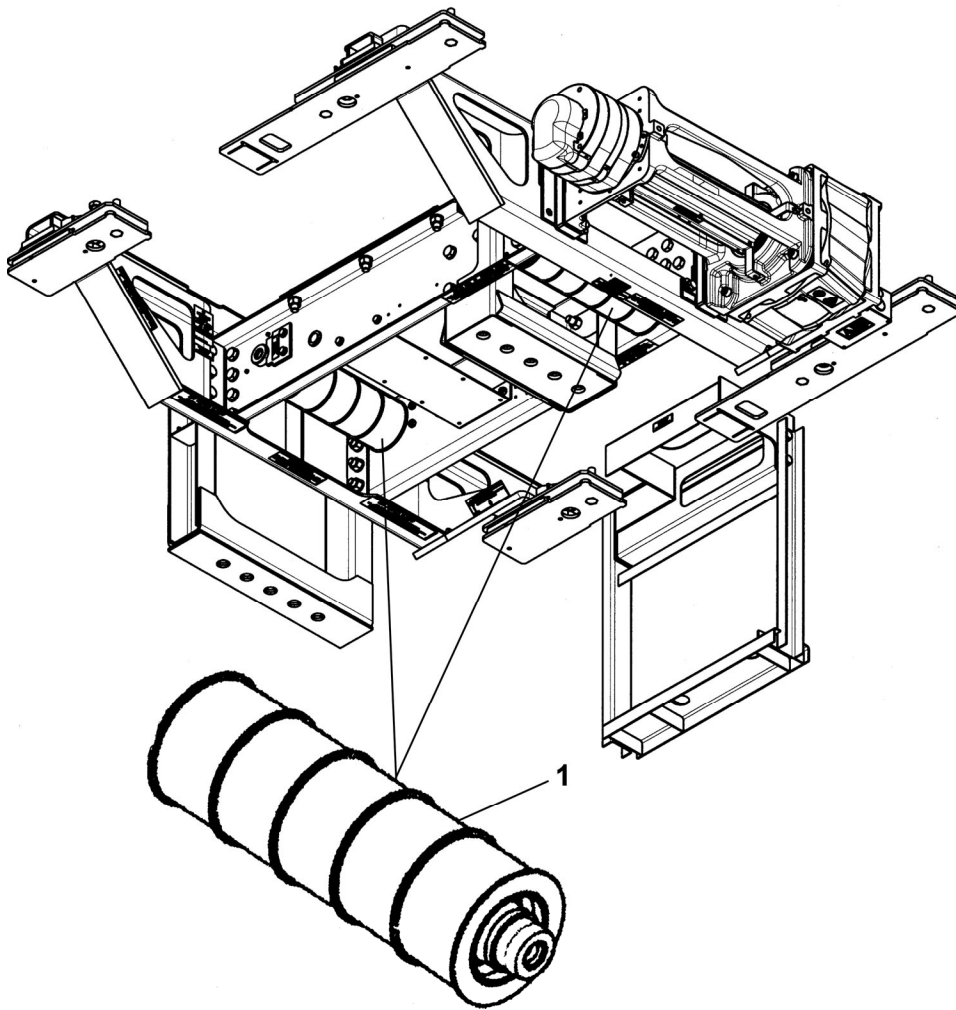

	<b>AAA20238Y</b> <b>ABA20238Y</b>	
<b>REF. No.</b>	<b>PART No.</b>	<b>DESCRIPTION</b>
1	AAA20780C5 AAA20780W4 AAA20780AS1	Assembly, Sheave
*	AAA349C1	Compound, Anti-Fretting