

Hydraulic Machine Tank Assembly (HydroFit® MRL)

Spare Parts Leaflet

06-AAA20390AG

August 22, 2018 / Page 1 of 12

	
HYDRAULIC MACHINE	
MODEL No.	
VOLTS	H. P.
PHASE	HERTZ
COMPONENT VINTAGE No.	
AAA20390AG	
COMPONENT CODE 06	

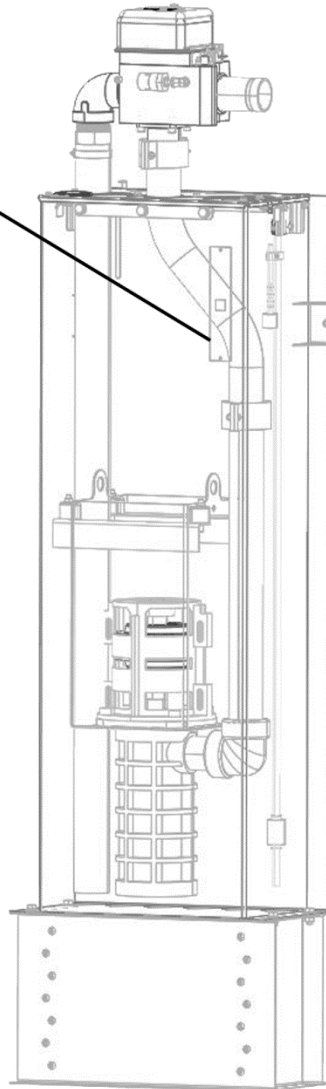

OTIS

This document does not contain any
technical data subject to EAR or ITAR

SERVICE ENGINEERING
Otis Elevator Company
Bloomfield, Connecticut USA

Unpublished Work—© Otis Elevator Co.; 2018

Leaflet Description

This leaflet provides information for replacement parts for Otis HydroFit® machine roomless submersible pump and motor hydraulic machines. This includes the 4500(H), 5000(H), and 5000(A) duties.

Leaflet Revisions

Date Revised	Subject Matter Expert	Reason for Revision
May 8, 2013	Art McClement	New SPL
August 22, 2018	Troy Chicoine and David Nelson	Added new p. 12 with hydraulic muffler assembly information

Related Drawings

Drawing No.	Title	Drawing No.	Title
AAA20390AG	Hydraulic Machine Assembly and Arrangement	---	---
---	---	---	---

Related Documents

Document ID	Title
OMM 6.3-A	<i>Hydraulic Elevator Maintenance</i>
SWP 17.0.1-A	<i>Safety Alerts</i>
TIP 28.3-7	<i>Replacing Pump and Motor on Hydraulic MRL Elevators</i>

Subject Matter Expert

Name	Department
Troy Chicoine	OSC Service Engineering

About Spare Parts Leaflets...

This document lists the lowest replaceable units (LRUs) for the standard version of the product. The LRUs are chosen by a team of Otis associates representing engineering and manufacturing.





While goal of this document is to make parts identification as easy as possible, the document cannot be all-inclusive. Elevator and escalator contracts classified as “special” or “custom” are not addressed here. For such contracts, please refer to specified information, the contract folder, TIPs, Field Education Articles, Construction Letters, etc. for further information.

If you have any suggestions about this document, please contact the subject matter expert listed on this page.

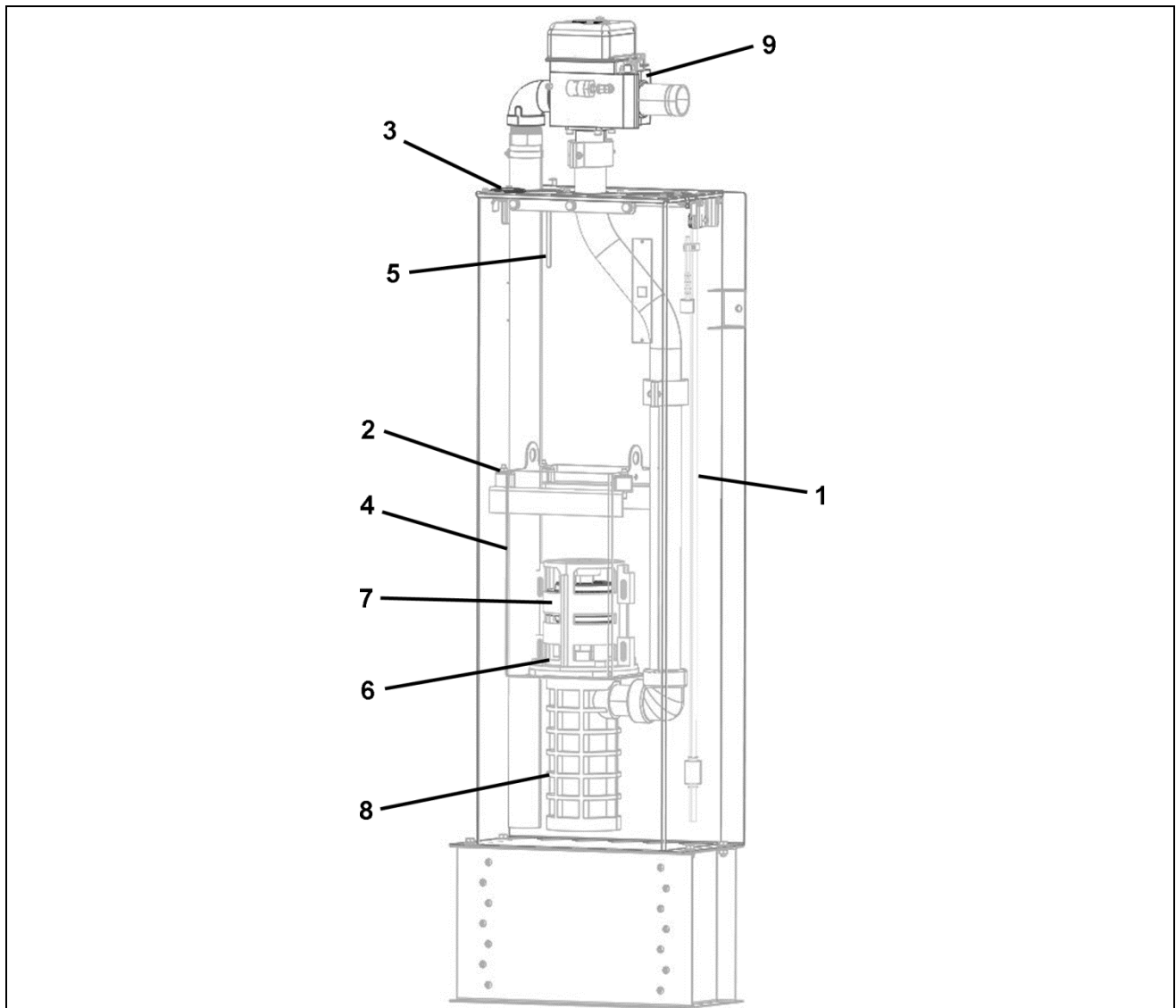
Hydraulic Machine

06-AAA20390AG



REF. No.	PART No.	DESCRIPTION
1	---	Assembly, Hydraulic Sensor Tree  p. 9
2	AAA310XB1	Block, Vibration-Damping Mounts
3	334H27	Bushing, Insulating
4	AAA325AC1	Cup, Hydro Motor Inner Tank (Partially Shown)
5	AAA269BJ1	Dipstick
6	AAA376HN1	Gasket, Pump—Motor
7	---	Motor, Type AAA20350F  p. 6
8	---	Pump, Type AAA20330A  p. 5
9	---	Valve, Hydraulic Control  p. 7

*Part not shown.

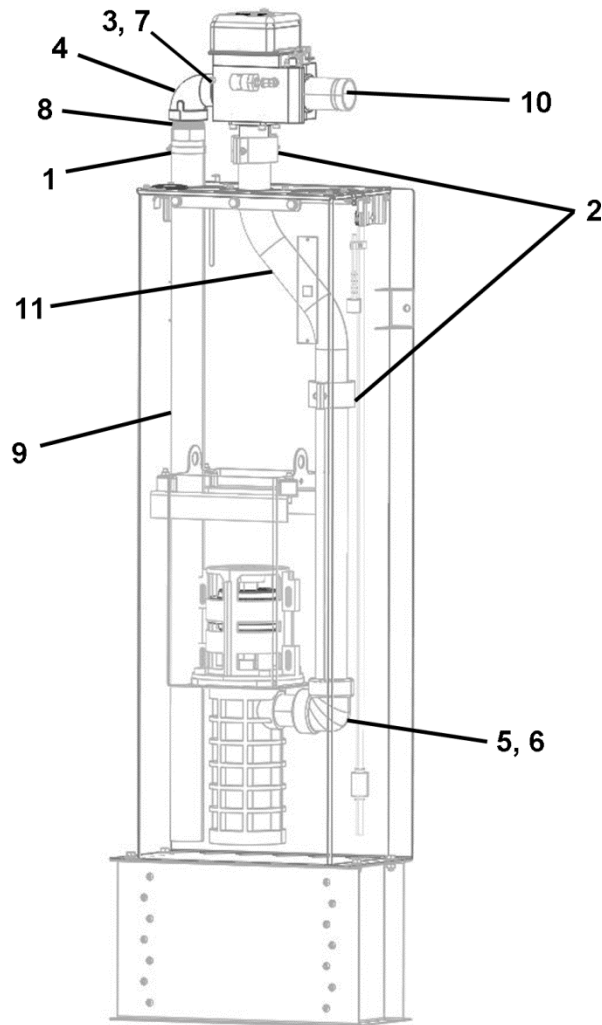

AAA20390AG			
REF. No.	PART No.	DESCRIPTION	LENGTH (mm) in.
1	336KL2	Clamp, Hose	---
2	441AS16	Coupling, Victaulic, 2 in.	---
3	AAA441GP1	Coupling, Pipe, 2 in. NPT Both Ends	---
4	377DJ9	Fitting, 90° Elbow, 2 x 2 in. NPT, Male x Female	---
5	AAA441GH2	Fitting, Pipe, 90° Elbow, 2 x 2 in. NPT, Female x Female	---
6	441AP165	Fitting, Pipe, 2 in. NPT Both Ends	(140) 5.5
7	441AP166	Fitting, Pipe, 2 in. NPT Both Ends	(50.8) 2.0
8	AAA441GQ1	Fitting, Pipe, 2 in. Male NPT to 2 in. Barbed Adapter	(114) 4.5
9	AAA377GY3	Pipe, Neoprene, 2 in. ID, 4 ft. Pit	(1339) 52.75
	AAA377GY4	Pipe, Neoprene, 2 in. ID, 5–6 ft. Pit	(1644) 64.75
10	441AP11	Pipe, 2 in. Ext. NPT x 2 in. Victaulic Grooved	(254) 10.0
	441AP18	Pipe, 2 in. Ext. NPT x 2 in. Victaulic Grooved	(152) 6.0
11	AAA377GW1	Pipe, 5.88 in. Offset, 2 in. Victaulic Grooved Both Ends	(465) 18.3

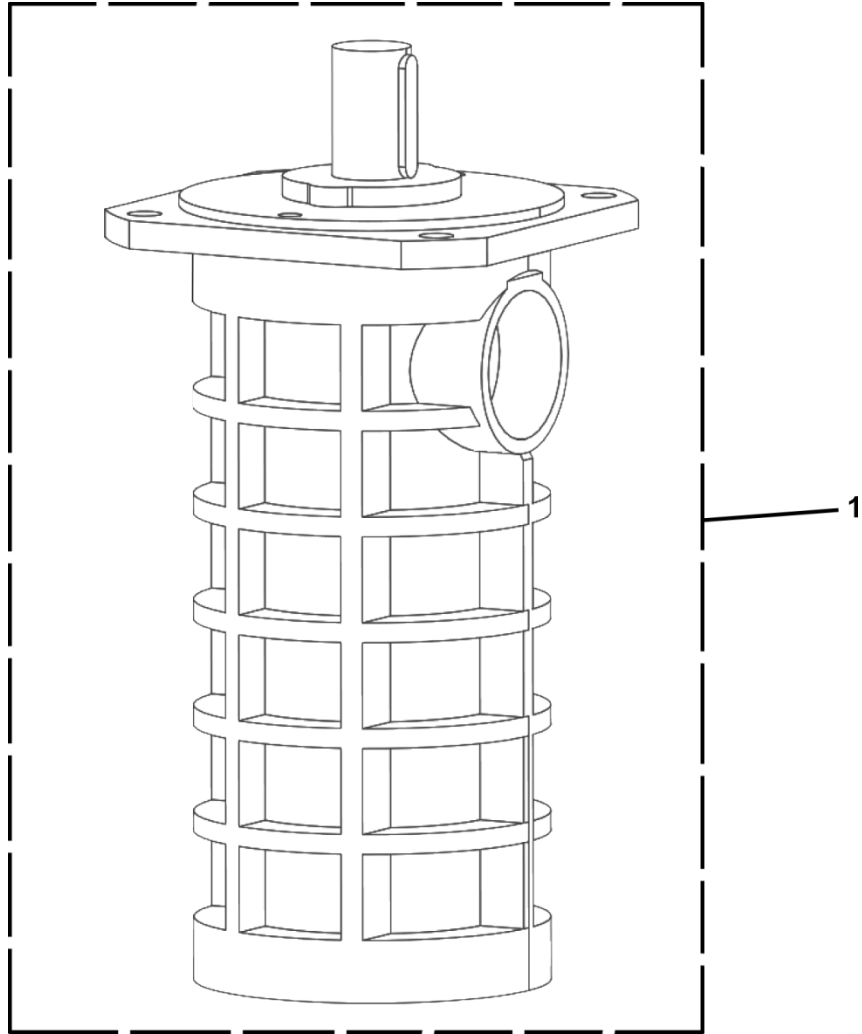

REF. No.	PART No.	MACHINE SIZE	FLOW RATE (GPM)
1	AAA20330A1	5615S-5625S	56
	AAA20330A2	7515S-7530S	75
	AAA20330A3	9420S-9440S	94
	AAA20330A4	12020S-12040S	120

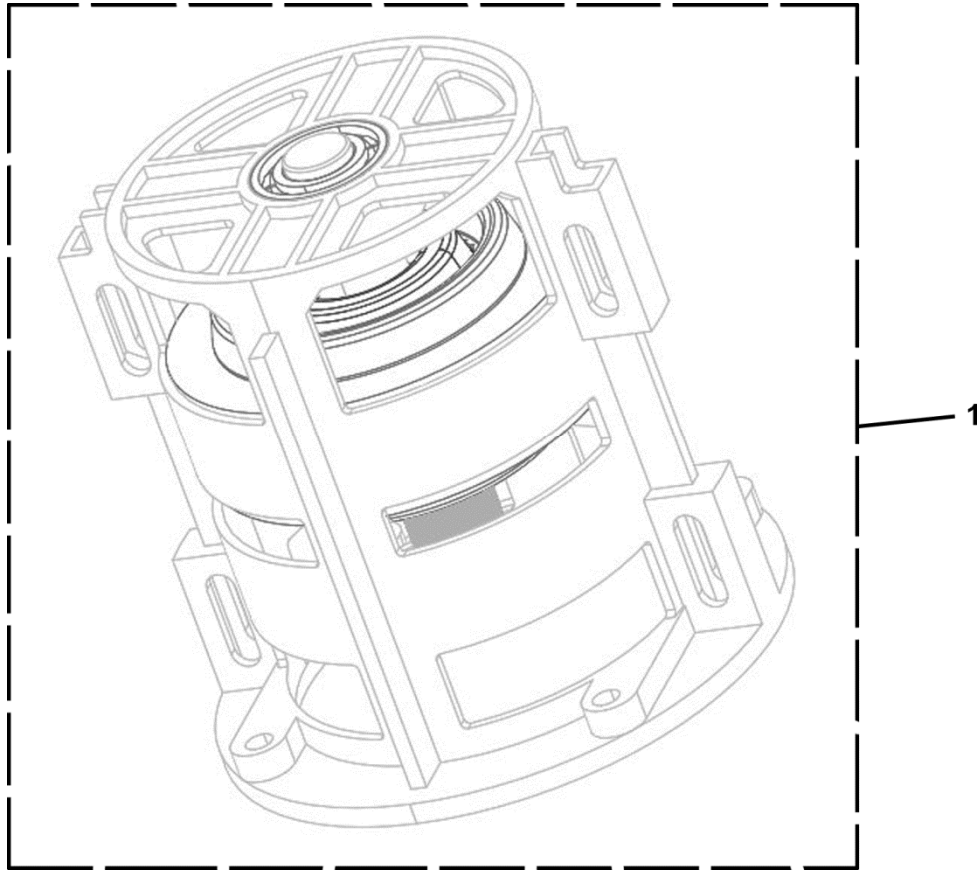

REF NO.	PART NO.			MACHINE SIZE	MOTOR HP
	MOTOR VOLTAGE				
	208 V	220/460 V	575 V		
1	AAA20350F1	AAA20350F2	AAA20350F3	5615S-7515S	15
	AAA20350F4	AAA20350F5	AAA20350F6	5620S-12020S	20
	AAA20350F7	AAA20350F8	AAA20350F9	5625S-12025S	25
	AAA20350F10	AAA20350F11	AAA20350F12	7530S-12030S	30
	AAA20350F13	AAA20350F14	AAA20350F15	9440S-14040S	40

Hydraulic Control Valve

06-AAA20390AG

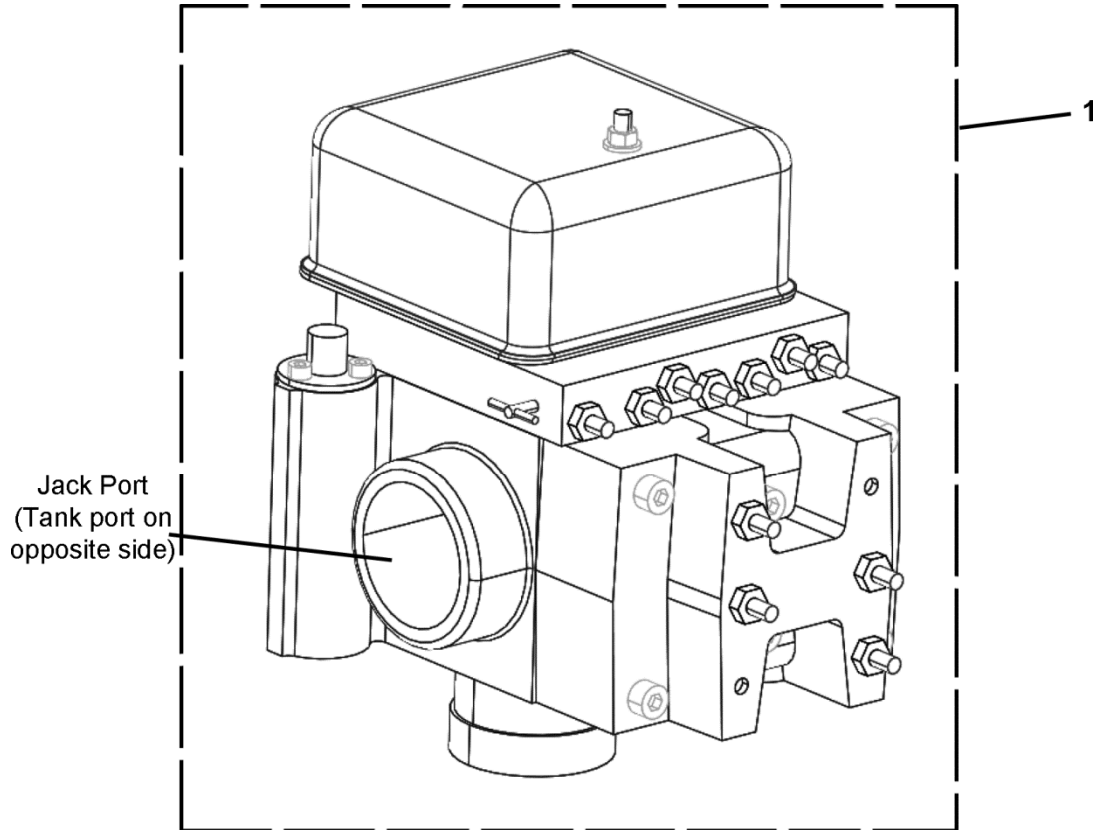

UC-4M Shown
(Tank and Jack Outlets
Opposite for UC-4)

REF. No.	PART No.	MACHINE SIZE	DESCRIPTION
1	271AP11	5615S-5625S	Maxton, UC-4M (E1) Pump Port, 2 in. Groove, Others 2 in. NPT
	AAA271DL13		Maxton, UC-4 (E1) Pump Port, 2 in. Groove, Others 2 in. NPT
	271AP12	7515S-9440S	Maxton, UC-4M (E2) Pump Port, 2 in. Groove, Others 2 in. NPT
	AAA271DL14		Maxton, UC-4 (E2) Pump Port, 2 in. Groove, Others 2 in. NPT
	271AP13	12020S-12040S	Maxton, UC-4M (STD) Pump Port, 2 in. Groove, Others 2 in. NPT
	AAA271DL15		Maxton, UC-4 (STD) Pump Port, 2 in. Groove, Others 2 in. NPT

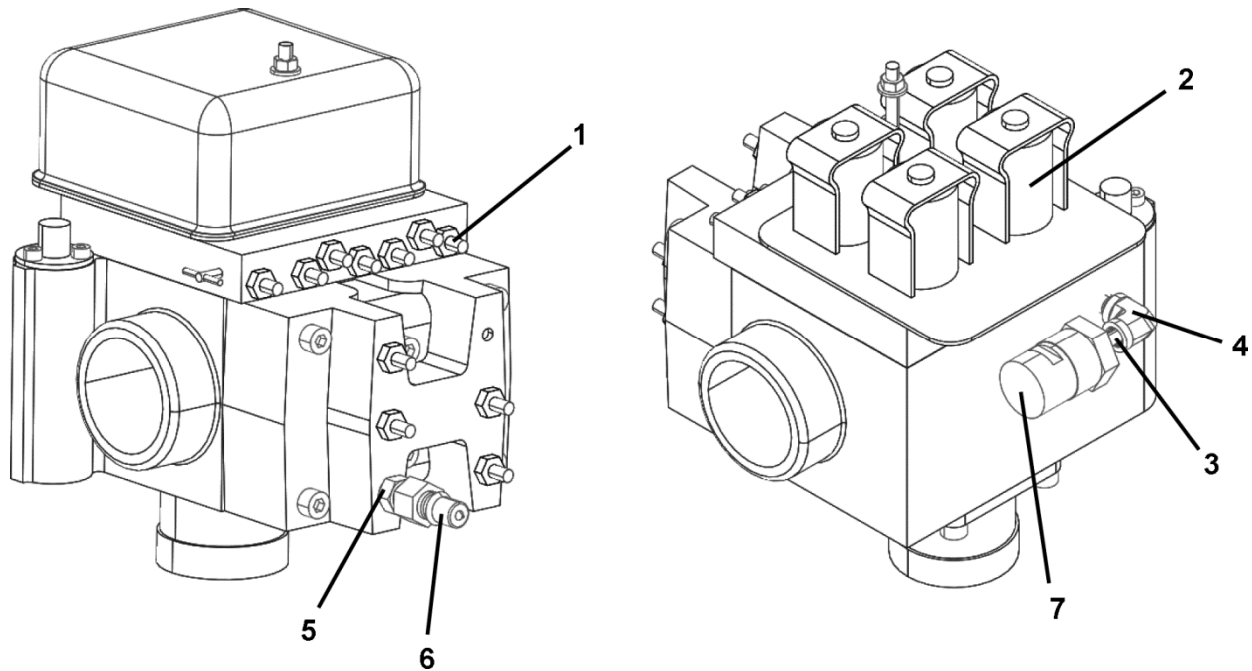

REF. No.	PART No.	DESCRIPTION
1	MAXT280070	Assembly, Adjuster Screw
2	MAXT208200	Coil, Individual, 115 VAC / 24 VDC, Red
3	441DK19	Fitting, Pipe (1/4-18 NPT x NPT Nipple)
4	AAA441GG2	Fitting, Pipe (1/8 in. Male x Female NPT 90° Elbow)
*	AAA20302A2	Kit, Seal
*	AAA20302A5	Kit, Solenoid
5	377DM3	Pipe, Hex Nipple (1/8 x 1/4 in. NPT)
6	377DR2	Pipe, Plug 2-Way Shut-off, Hansen Quick-Connect
7	AAA20300L2	Valve, Mounted Low Pressure Switch

* Part not shown.

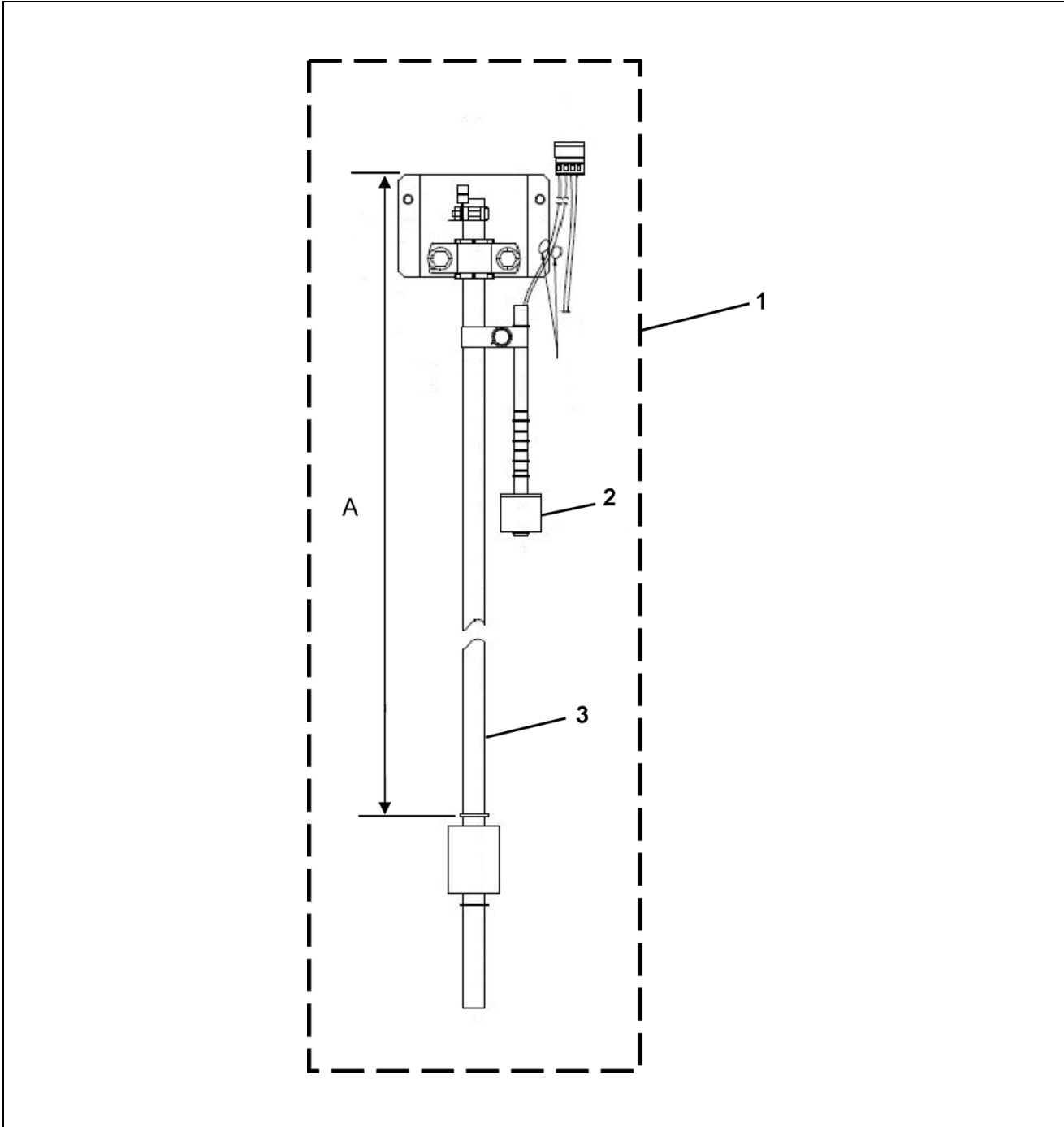

REF. No.	PART No.	DESCRIPTION	A (mm) in.
1	AAA20390AD1	Assembly, Hydraulic Sensor Tree	(1103.9) 43.5
	AAA20390AD2	Assembly, Hydraulic Sensor Tree	(1408.7) 55.5
2	AAA20390X1	Switch, Oil Level	---
3	AAA20390W7	Switch, Temperature, Used w/ AAA20390AD1	---
	AAA20390W8	Switch, Temperature, Used w/ AAA20390AD2	---

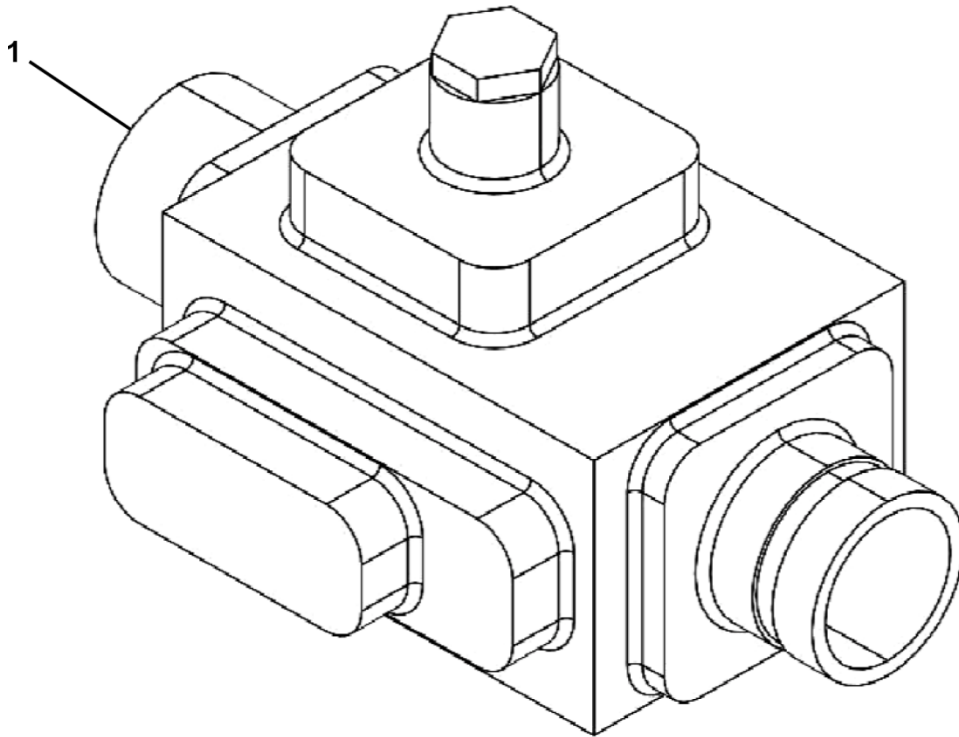

REF. No.	PART No.	DESCRIPTION
*	AAA20302A3	Seal Kit, Pipe Rupture Valve
1	AAA271DH3	Valve, Pipe Rupture, 2 in. Victaulic Ends, Less than 100 GPM
	AAA271DH1	Valve, Pipe Rupture, 2 in. Victaulic Ends, More than 100 GPM
	AAA271DH7	Valve, Pipe Rupture, 2 in. NPT One End, 2 in. Victaulic Other End, Less than 100 GPM (for Massachusetts)

* Part not shown.

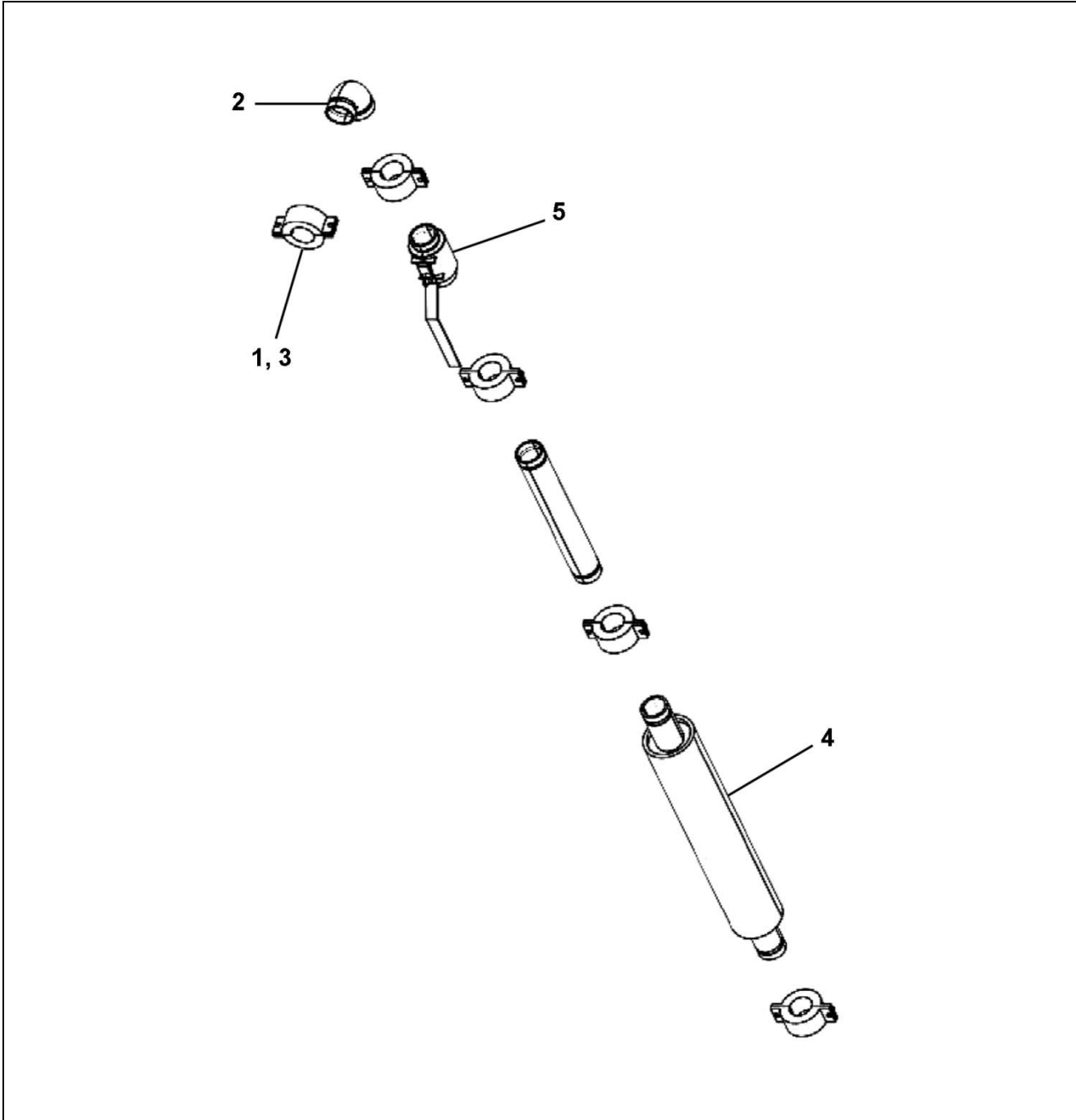

REF. No.	PART No.	DESCRIPTION
1	441AS3	Coupling, Victaulic Style 77 STD Size 2 in. (flexible)
2	441BC1	Elbow, Pipe Victaulic, 90°, 2 in.
3	AAA376GK3	Gasket, Victaulic, 2 in.
4	AAA726G1	Muffler
5	271AS6	Valve, Ball, 2 in., Victaulic Ends (working pressure < 1000 PSI)
*	VP-740650	Viclube, Gasket Lubricant, 4.5 oz. Tube

*Part not shown

AAA726K Hydraulic Muffler Assembly

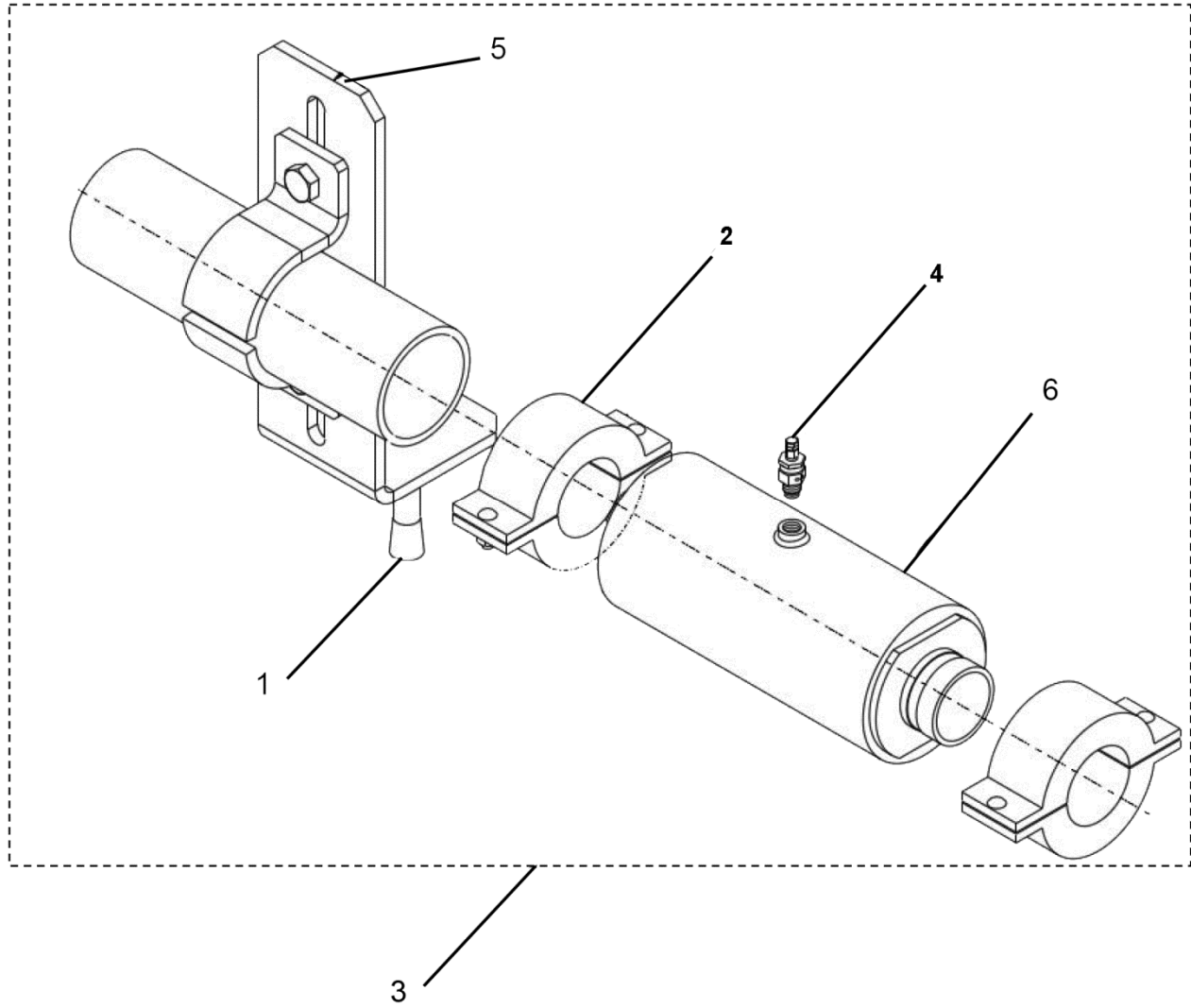

REF. No.	PART No.	DESCRIPTION
1	54E27	Anchor, Concrete, 1/2 in.
2	441AS3	Coupling, Grooved, 2 in.
3	AAA726K3	Kit, 100 GPM Silencer w/ Mounting Hardware
	AAA726K4	Kit, 220 GPM Silencer w/ Mounting Hardware
4	AAA726K500	Kit, Valve Stem
5	AAA471LF1	Pipe, Stand, 2 in.
6	AAA726K1	Silencer 2 in. X 2 in. GRV (100 GPM)
	AAA726K2	Silencer 2 in. X 2 in. GRV (220 GPM)