

5T EN Brake for Gen2 System

Spare Parts Leaflet

07-TAA20236H

Nov. 2003 / Page 1 of 5

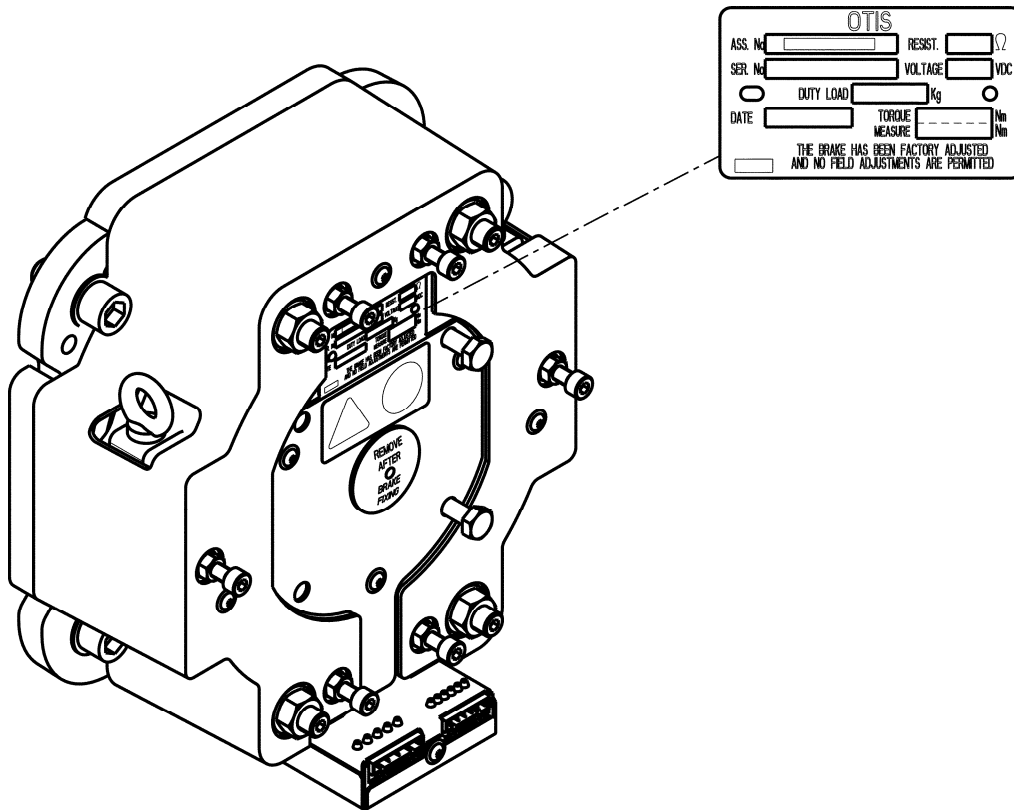

OTIS

Safety First!

OTIS ENGINEERING CENTER
Madrid
Otis Elevator Company

Leaflet Description

This leaflet provides spare parts information for type TAA20236H disc brake. The disc brake was designed specially for the Gen2 machine roomless elevator system.

Leaflet Revisions

Date Revised	Subject Matter Expert	Reason for Revision
Nov. 2003	J. M. Aguado	New leaflet

Related Drawings

Drawing No.	Title	Drawing No.	Title
TAA20236H	Brake	---	---

Related Documents

Document ID	Title

Subject Matter Expert

Name	Department
J. M. Aguado	Global Proj. OEC-Madrid

About Spare Parts Leaflets...

This document lists the lowest replaceable units (LRUs) for the standard version of the product. The LRUs are chosen by a team of Otis associates representing engineering and manufacturing.

While goal of this document is to make parts identification as easy as possible, the document cannot be all-inclusive. Elevator and escalator contracts classified as "special" or "custom" are not addressed here. For such contracts, please refer to specified information, the contract folder, TIPs, Field Education Articles, Construction Letters, etc. for further information.

If you have any suggestions about this document, please contact the subject matter expert listed on this page.

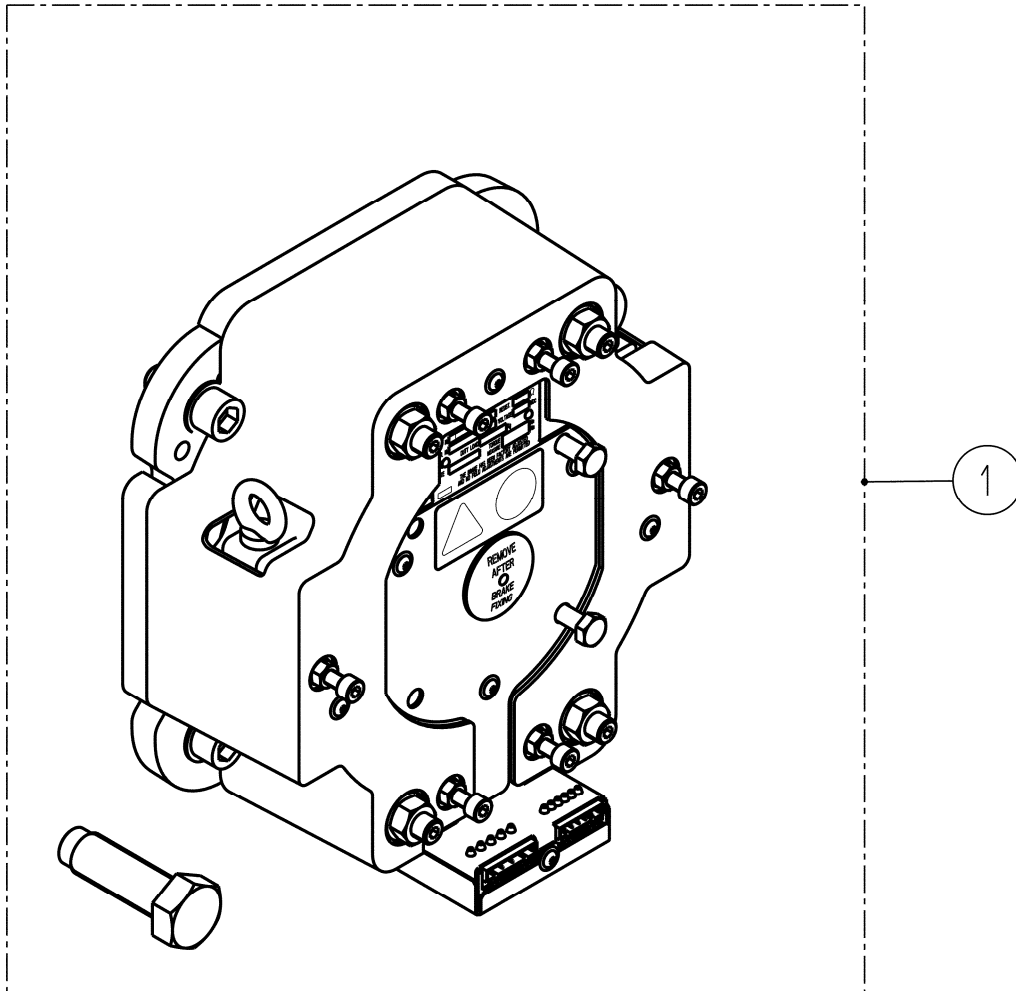

TAA20236H					
REF. No.	DUTY LOAD (kg)	SPEED (m/s)	VOLTAGE (v)	SENSORS	ARRANGEMENT
1	≤ 2000	≤ 1.78	20	WITH	TAA20236H1 + TAA124EK1 + TAA5300KY2
	≤ 1600				TAA20236H2 + TAA124EK1 + TAA5300KY2

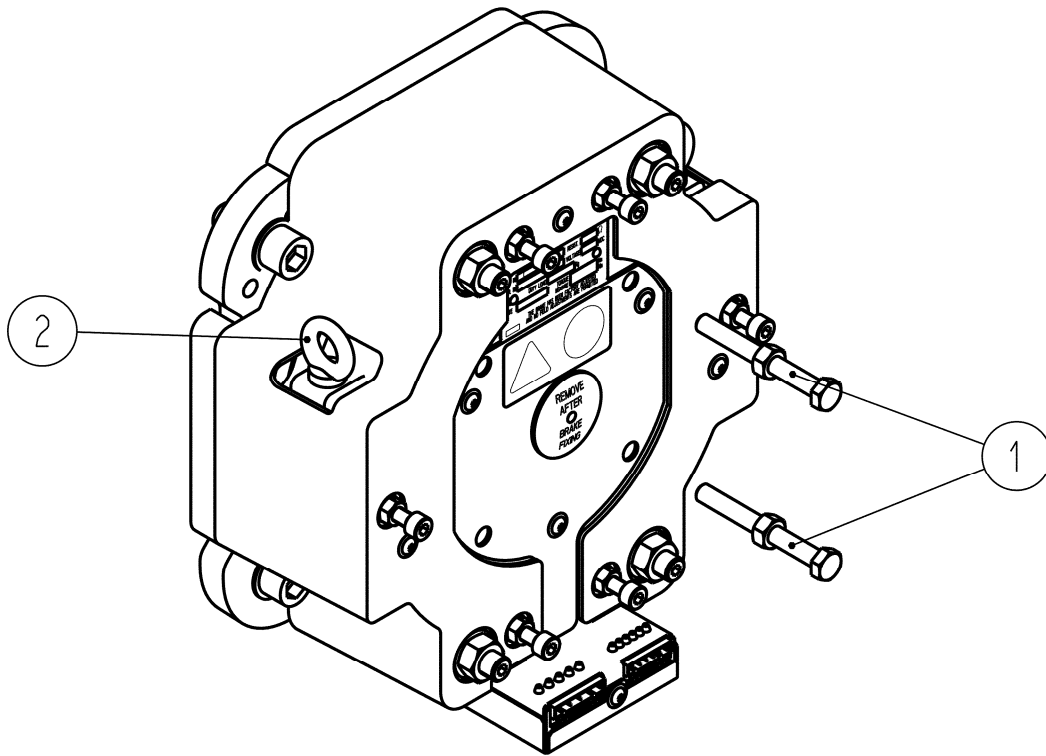

TAA20236H			
REF. No.	PART No.		DESCRIPTION
1	TAA5300KY1	TAA20236H1 ÷ 2	Screw + Nut
2	(2) DIN580 M8	TAA20236H1 ÷ 2	Lifting Bolt

5T EN Brake for Gen2 System

07-TAA20236H

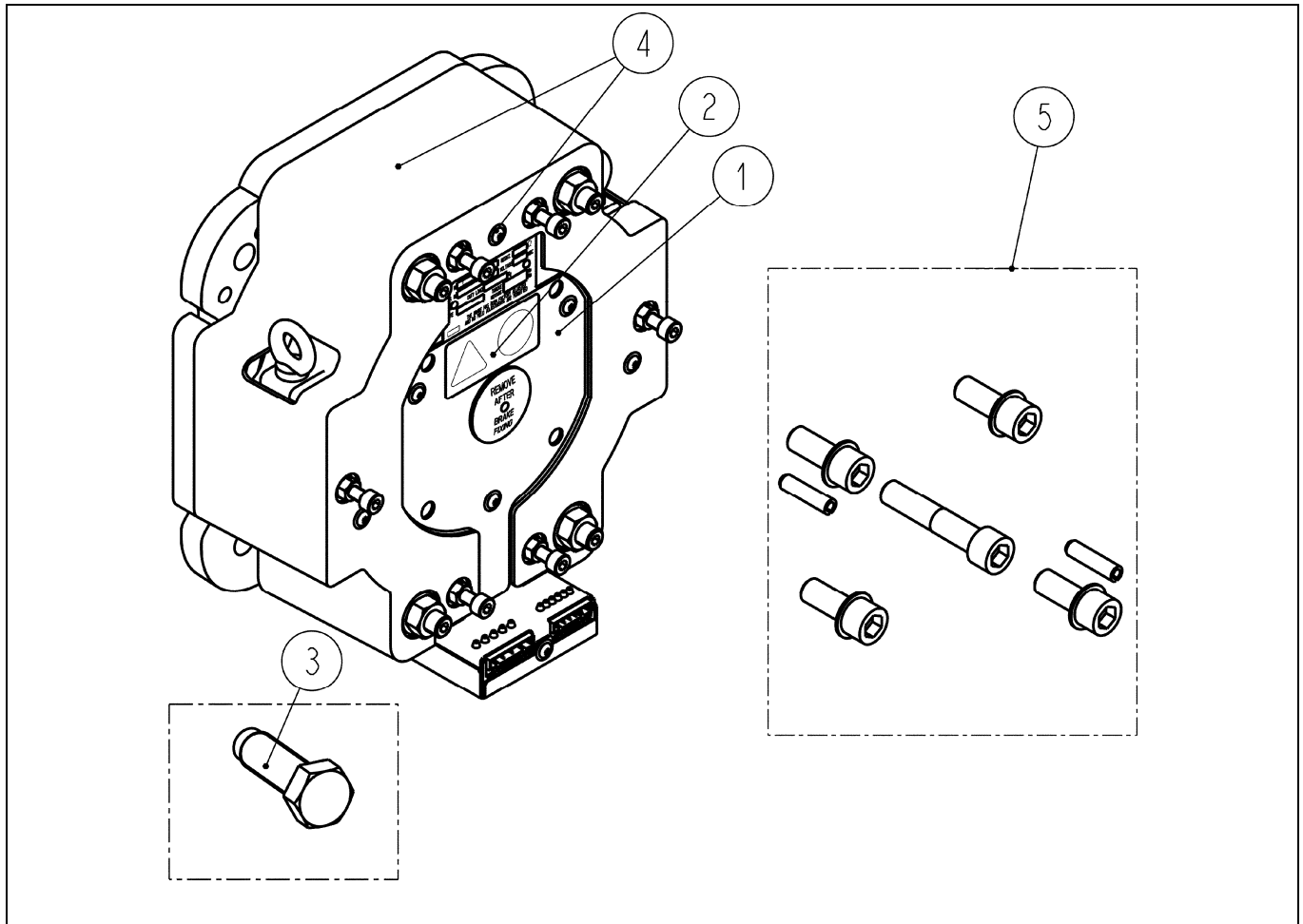

TAA20236H			
REF. No.	PART No.	W →	DESCRIPTION
1	TAA346PE1	TAA20236H1 ÷ 2	Cover
	(3) TAA124EJ1	TAA20236H1 ÷ 2	Screw
2	TAA102GW1	TAA20236H1 ÷ 2	Label
3	TAA124EK1	TAA20236H1 ÷ 2	Screw
4	TAA384JM1	TAA20236H1 ÷ 2	Guard
	(3) TAA124EJ1	TAA20236H1 ÷ 2	Screw
5	TAA5300KY2	TAA20236H1 ÷ 2	Hardware Kit for Assembling the Brake on the Machine. Consists of: (2) Pins ISO8752-10x40 (4) Washers TAA130AT4 (4) Screw ISO4762 M16x50-8.8 (1) Screw ISO4762 M16x80-10.9 (1) Washer DIN6796-16