

**CONTROLLER PART
MAIN SWITCH & RELAY
SIEMENS (SIRIUS 3R)**

**Spare Parts Leaflet
10-GAA613GL-GN
JUL 2009 / Page 1 of 16**

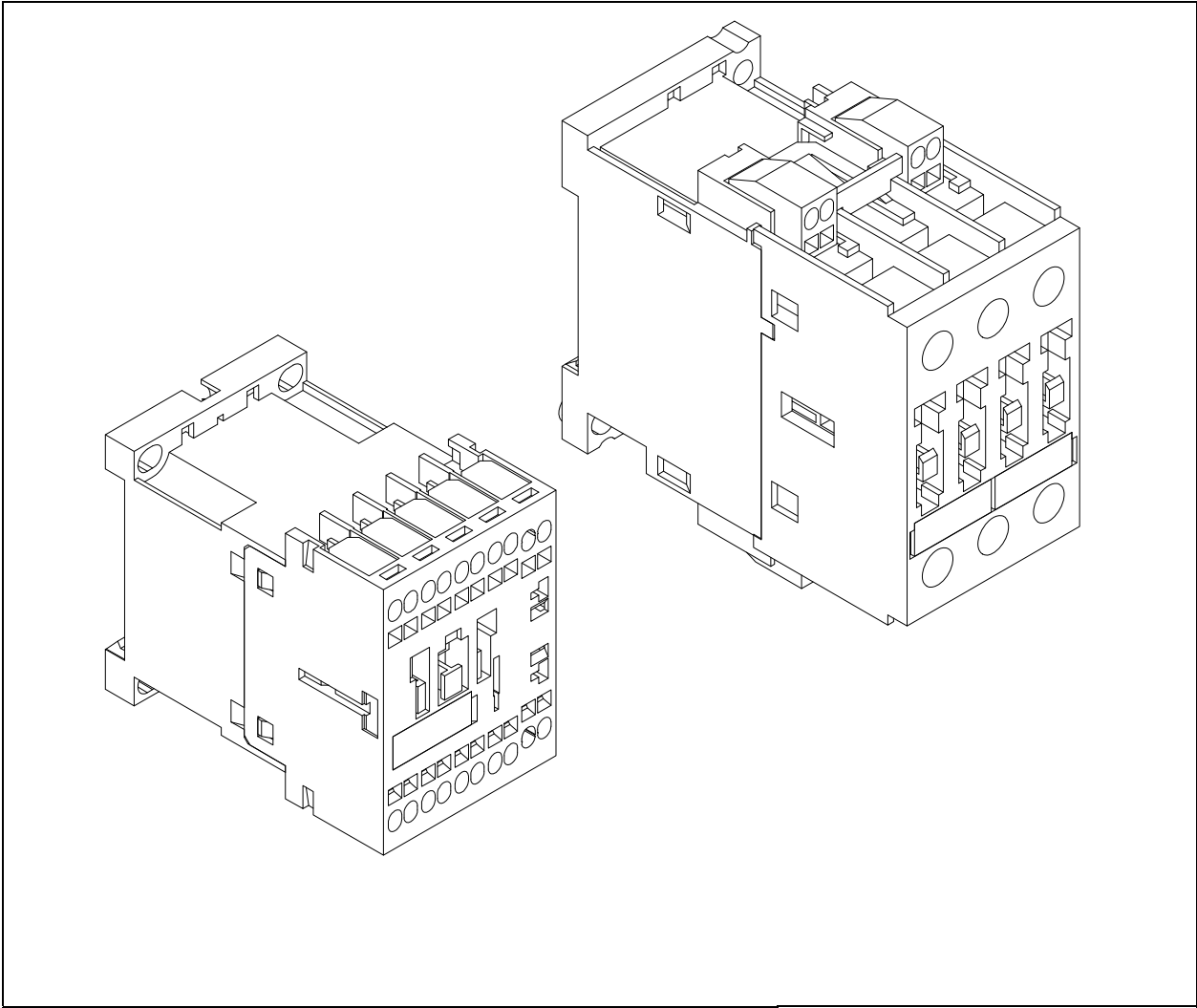

Unpublished Work—© Otis Elevator Co.; 2009

OTIS

Safety First!

**OEC BERLIN
Otis Elevator Company
Berlin, Germany**

10-GAA613GL-GN

History

Leaflet Description

The leaflet describes controller parts like main switches and relays from Siemens (Sirius 3R). The description includes :

- Type (3RT....)
- The rated coil voltage
- Number of contacts (NC, NO, MAIN)
- Rated power or current at 400 VAC
- RC-Network, diodes and over voltage suppressor

Leaflet Revisions

Date Revised	Subject Matter Expert	Reason for Revision
July, 2009	Mustapha Toutaoui	GAA638GF1 added

Related Drawings

Drawing No.	Title	Drawing No.	Title

Related Documents

Document ID	Title

Subject Matter Expert

Name	Department
Mustapha Toutaoui	Engineering center Berlin

About Spare Parts Leaflets...

This document lists the lowest replaceable units (LRUs) for the standard version of the product. The LRUs are chosen by a team of Otis associates representing engineering and manufacturing.

While goal of this document is to make parts identification as easy as possible, the document cannot be all-inclusive. Elevator and escalator contracts classified as "special" or "custom" are not addressed here. For such contracts, please refer to specified information, the contract folder, TIPs, Field Education Articles, Construction Letters, etc. for further information.

If you have any suggestions about this document, please contact the subject matter expert listed on this page.

CONTROLLER PART MAIN SWITCH & RELAY SIEMENS (SIRIUS 3R)

10-GAA613GL-GN

MAIN SWITCH

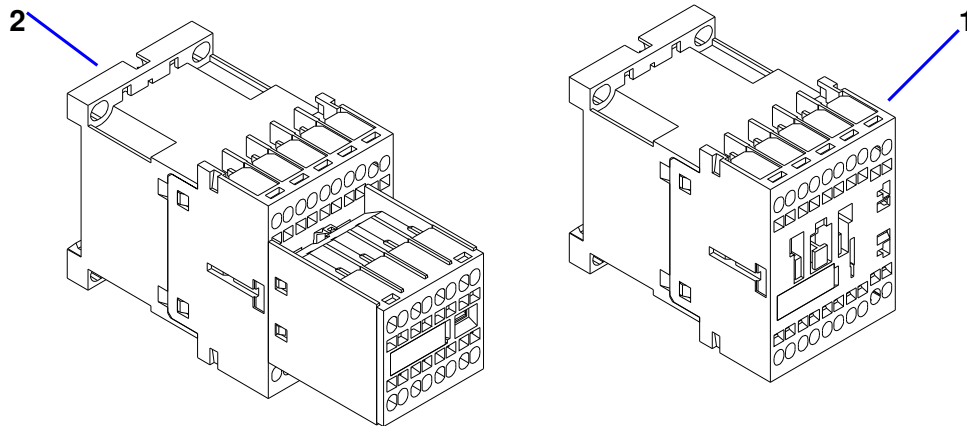

REF. No.	PART No.	DESCRIPTION						
		VINTAGE	TYPE	RATED COIL VOLTAGE	CONTACTS			RATED POWER AT 400 VAC
					NO	NC	MAIN	
1	GAA638DD1 *		3RT1017	110V; 50/60Hz	-	1	3	5.5 kW
	GAA638DG1 *			30VDC ±30% \ominus	1	-		4.0 kW
	GAA638CE1 *		3RT1015	110V; 50/60Hz	-	1	3.0 kW	
	GAA638DM1 *			48VDC				
	GAA638BH1 *			110V; 50/60Hz				
2	GAA638EX1 *			110V; 60Hz	2	2	3	4.0 kW
	GAA638BD1 *		3RT1016	48VDC				
	GAA638BD2 *			30VDC				
	GAA638BJ1 *			110V; 50/60Hz				
	GAA638BK1 *			110V; 60Hz				
	GAA638BK2 *			230V; 50/60Hz				
	GAA638BP1 *							
GAA638BP2 *								
	GAA638BY1 *		3RT1017					5.5 kW

10-GAA613GL-GN

CONTROLLER PART MAIN SWITCH & RELAY SIEMENS (SIRIUS 3R)

MAIN SWITCH

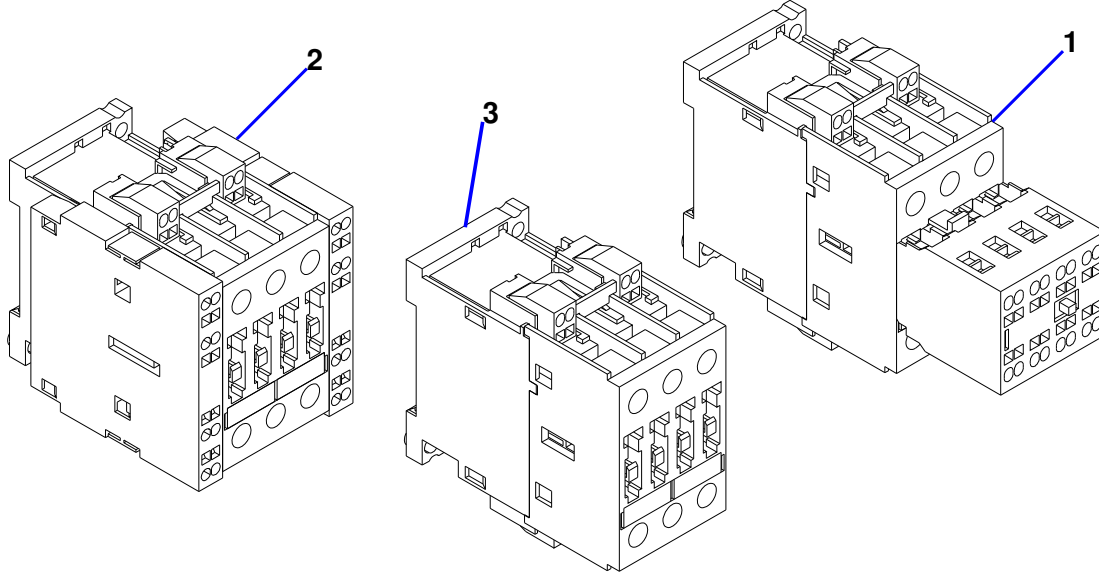

REF. No.	VINTAGE	DESCRIPTION											
	PART No.	TYPE	RATED COIL VOLTAGE	CONTACTS			RATED POWER AT 400 VAC						
				NO	NC	MAIN							
1	GAA638BE1 *	3RT1024	110V; 50Hz	2	2	3	5.5 kW						
	GAA638BE2 *		110V; 60Hz										
	GAA638BL1 *		48VDC										
	GAA638BM1 *	3RT1025	110V; 50Hz				2	2	3	7.5 kW			
	GAA638BM2 *		110V; 60Hz										
	GAA638CK1 *		48VDC										
	GAA638BN1 *	3RT1026	110V; 50Hz							2	2	3	11.0 kW
	GAA638BN2 *		110V; 60Hz										
	GAA638CL1 *		48VDC										

CONTROLLER PART MAIN SWITCH & RELAY SIEMENS (SIRIUS 3R)

10-GAA613GL-GN

MAIN SWITCH

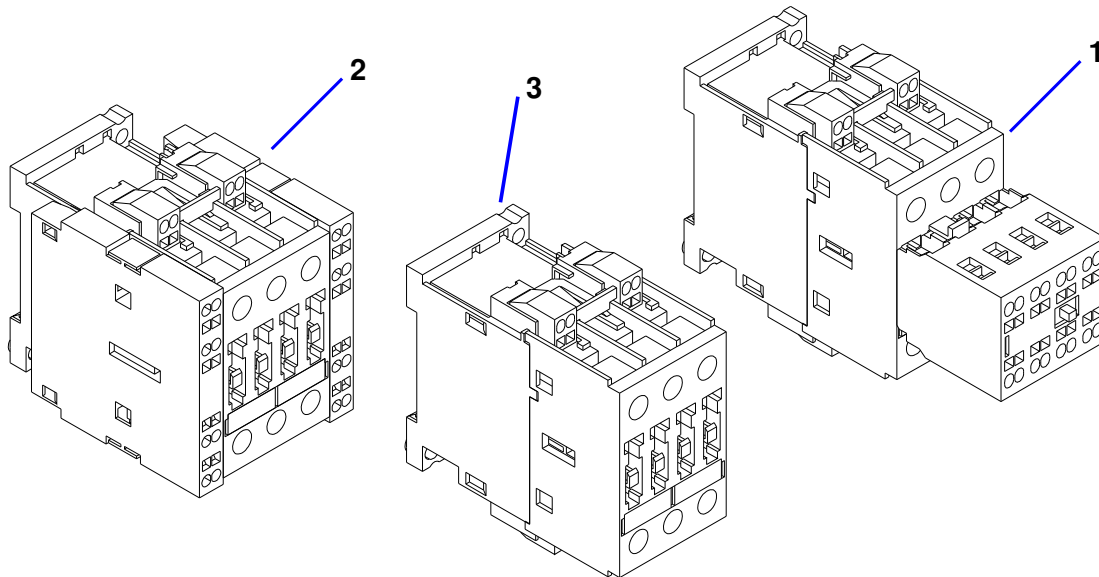

REF. No.	PART No.	DESCRIPTION					
		TYPE	RATED COIL VOLTAGE	CONTACTS			RATED POWER AT 400 VAC
				NO	NC	MAIN	
2	GAA638DA1 *	3RT1024	110V; 50Hz	2	2	3	5.5 kW
	GAA638DA2 *		110V; 60Hz				
	GAA638BZ1 *	3RT1025	230V; 50Hz				7.5 kW
	GAA638BZ2 *		230V; 60Hz				
	GAA638BZ3 *		230V; 50/60Hz				
	GAA638BZ4 *		110V; 50Hz				
	GAA638BZ5 *		110V; 60Hz				
	GAA638CA1 *	3RT1026	230V; 50Hz				11.0 kW
	GAA638CA2 *		230V; 60Hz				
	GAA638CA3 *		230V; 50/60Hz				
	GAA638CA4 *		110V; 50Hz				
GAA638CA5 *	110V; 60Hz						
3	GAA638DT1 *	3RT1024	110V; 50/60Hz				5.5 kW
	GAA638DV1 *	3RT1035					7.5 kW
	GAA638DW1 *	3RT1026					11.0 kW

10-GAA613GL-GN

CONTROLLER PART MAIN SWITCH & RELAY SIEMENS (SIRIUS 3R)

MAIN SWITCH

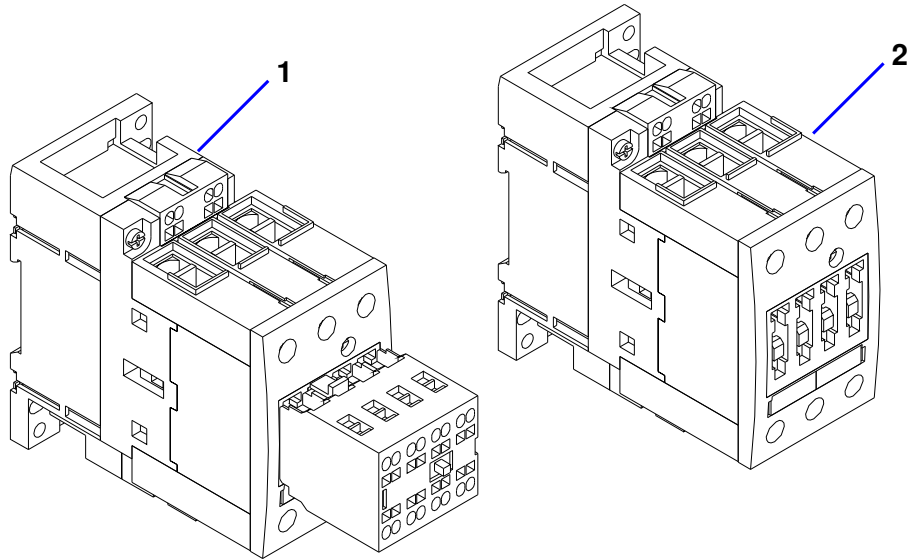

REF. No.	PART No.	DESCRIPTION											
		TYPE	RATED COIL VOLTAGE	CONTACTS			RATED POWER AT 400 VAC						
				NO	NC	MAIN							
1	GAA638BF1 *	3RT1034	110V; 50Hz	2	2	3	15.0 kW						
	GAA638BF2 *		110V; 60Hz										
	GAA638CM1 *		48VDC										
	GAA638CN1 *	3RT1035	110V; 50Hz				2	2	3	18.5 kW			
	GAA638CN2 *		110V; 60Hz										
	GAA638CP1 *		48VDC										
	GAA638CR1 *	3RT1036	110V; 50Hz							2	2	3	22.0 kW
	GAA638CR2 *		110V; 60Hz										
	GAA638CS1 *		48VDC										
2	GAA638DC1 *	3RT1034	230V; 50Hz	-	-								15.0 kW
	GAA638DC2 *		230V; 60Hz										
	GAA638DX1 *	3RT1035	110V; 50/60Hz										-
	GAA638DY1 *	3RT1036	110V; 50/60Hz				22.0 kW						

CONTROLLER PART MAIN SWITCH & RELAY SIEMENS (SIRIUS 3R)

10-GAA613GL-GN

MAIN SWITCH

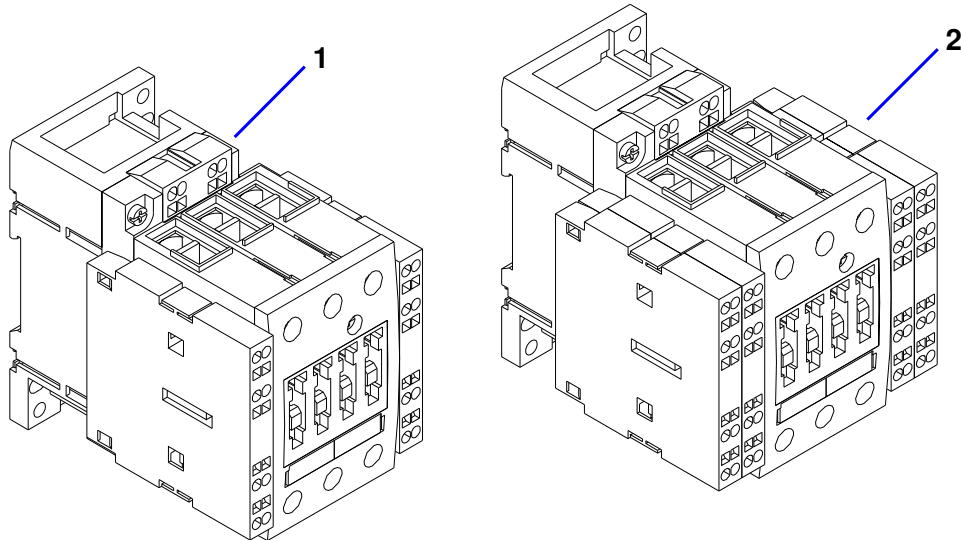

REF. No.	PART No.	DESCRIPTION												
		TYPE	RATED COIL VOLTAGE	CONTACTS			RATED POWER AT 400 VAC							
				NO	NC	MAIN								
1	GAA638CB1 *	3RT1034	230V; 50Hz	2	2	3	15.0 kW							
	GAA638CB2 *		230V; 60Hz											
	GAA638CB3 *		230V; 50/60Hz											
	GAA638CB4 *		110V; 50Hz											
	GAA638CB5 *		110V; 60Hz											
	GAA638CC1 *	3RT1035	230V; 50Hz				2	2	3	18.5 kW				
	GAA638CC2 *		230V; 60Hz											
	GAA638CC3 *		230V; 50/60Hz											
	GAA638DL1 *		110V; 50Hz											
	GAA638DL2 *	110V; 60Hz	3RT1036							230V; 50Hz	2	2	3	22.0 kW
	GAA638CD1 *	230V; 60Hz												
	GAA638CD2 *	230V; 50/60Hz												
	GAA638CD3 *	110V; 50Hz												
	GAA638CD4 *	110V; 60Hz												
	GAA638CD5 *													

CONTROLLER PART MAIN SWITCH & RELAY SIEMENS (SIRIUS 3R)

10-GAA613GL-GN

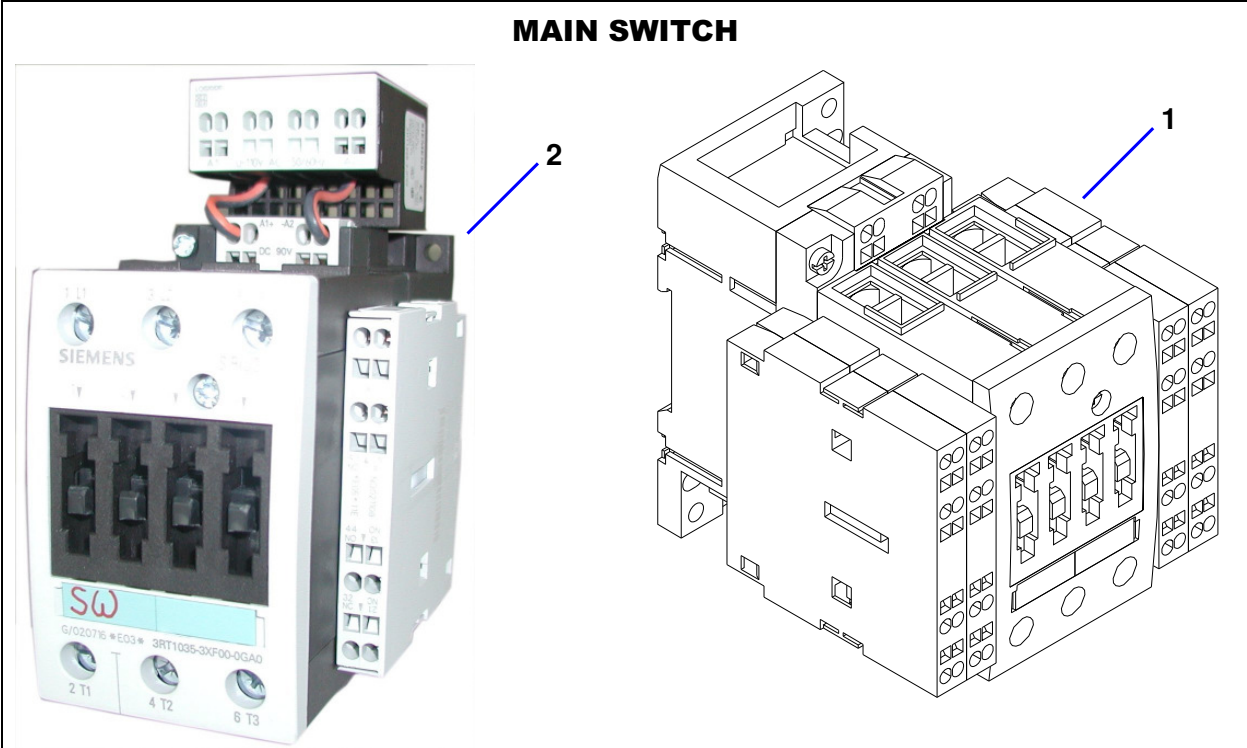

⊗) = 2 NORMAL CONTACTS + 1 CONTACT USED FOR ELECTRONIC CONTROL

REF. No.	VINTAGE		DESCRIPTION							
	PART No.	TYPE	RATED COIL VOLTAGE	CONTACTS			RATED POWER AT 400 VAC			
				NO	NC	MAIN				
1	GAA638EB1 *	3RT1034	110V; 50Hz	3 ⊗)	3 ⊗)	3	15.0 kW			
	GAA638EB2 *		110V; 60Hz							
	GAA638EA1 *	3RT1035	110V; 50Hz				2	2	3	18.5 kW
	GAA638EA2 *		110V; 60Hz							
2	GAA638EW1 *		110V; 60Hz							

10-GAA613GL-GN

CONTROLLER PART MAIN SWITCH & RELAY SIEMENS (SIRIUS 3R)

MAIN SWITCH

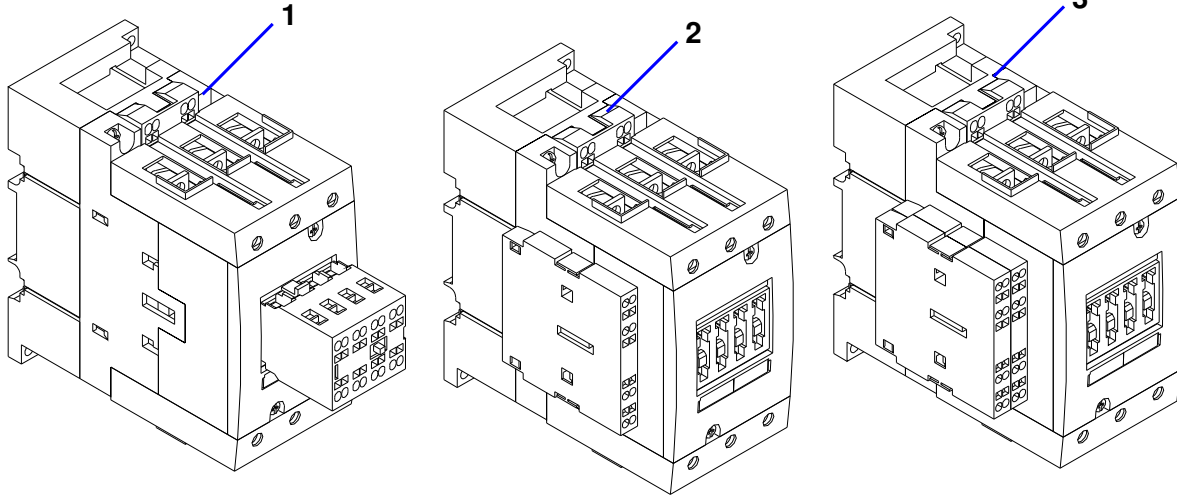

REF. No.	PART No.	DESCRIPTION					
		TYPE	RATED COIL VOLTAGE	CONTACTS			RATED POWER AT 400 VAC
				NO	NC	MAIN	
1	GAA638CT1 *	3RT1044	110V; 50Hz	2	2	3	30.0 kW
	GAA638CT2 *		110V; 60Hz				
	GAA638CV1 *		48VDC				
	GAA638CW1 *	3RT1045	110V; 50Hz				45.0 kW
	GAA638CW2 *		110V; 60Hz				
	GAA638CX1 *		48VDC				
	GAA638CY1 *	3RT1046	110V; 50Hz				30.0 kW
	GAA638CY2 *		110V; 60Hz				
GAA638CZ1 *	48VDC						
2	GAA638DN1 *	3RT1044	230V; 50Hz				
	GAA638DN2 *		230V; 60Hz				
	GAA638DN3 *		230V; 50/60Hz				
	GAA638DN4 *		110V; 50Hz				
	GAA638DN5 *		110V; 60Hz				

CONTROLLER PART MAIN SWITCH & RELAY SIEMENS (SIRIUS 3R)

10-GAA613GL-GN

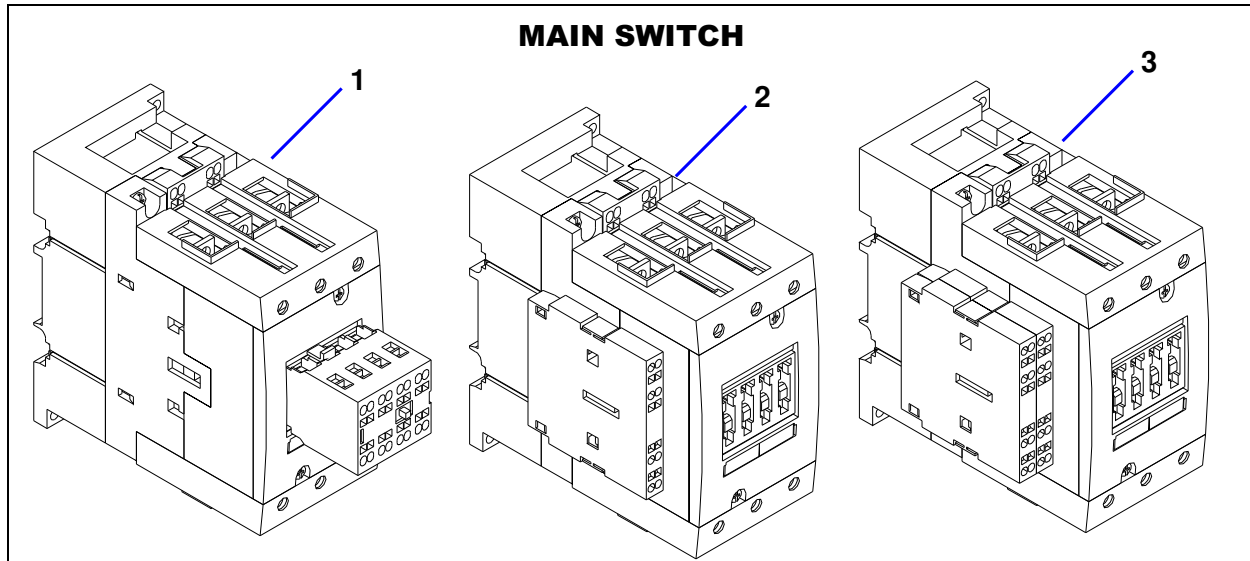

⊗) = 2 NORMAL CONTACTS + 1 CONTACT USED FOR ELECTRONIC CONTROL

REF. No.	VINTAGE	DESCRIPTION					
	PART No.	TYPE	RATED COIL VOLTAGE	CONTACTS			RATED POWER AT 400 VAC
				NO	NC	MAIN	
2	GAA638DP1 *	3RT1045	230V; 50Hz	2	2	3	37.0 kW
	GAA638DP2 *		230V; 60Hz				
	GAA638DP3 *		230V; 50/60Hz				
	GAA638DP4 *		110V; 50Hz				
	GAA638DP5 *		110V; 60Hz				
	GAA638DR1 *	3RT1046	230V; 50Hz				45.0 kW
	GAA638DR2 *		230V; 60Hz				
	GAA638DR3 *		230V; 50/60Hz				
	GAA638DR4 *		110V; 50Hz				
	GAA638DR5 *		110V; 60Hz				
3	GAA638DZ1 *	3RT1045	110V; 50Hz	3 ⊗)	3 ⊗)	37.0 kW	
	GAA638DZ2 *		110V; 60Hz				

10-GAA613GL-GN

CONTROLLER PART MAIN SWITCH & RELAY SIEMENS (SIRIUS 3R)

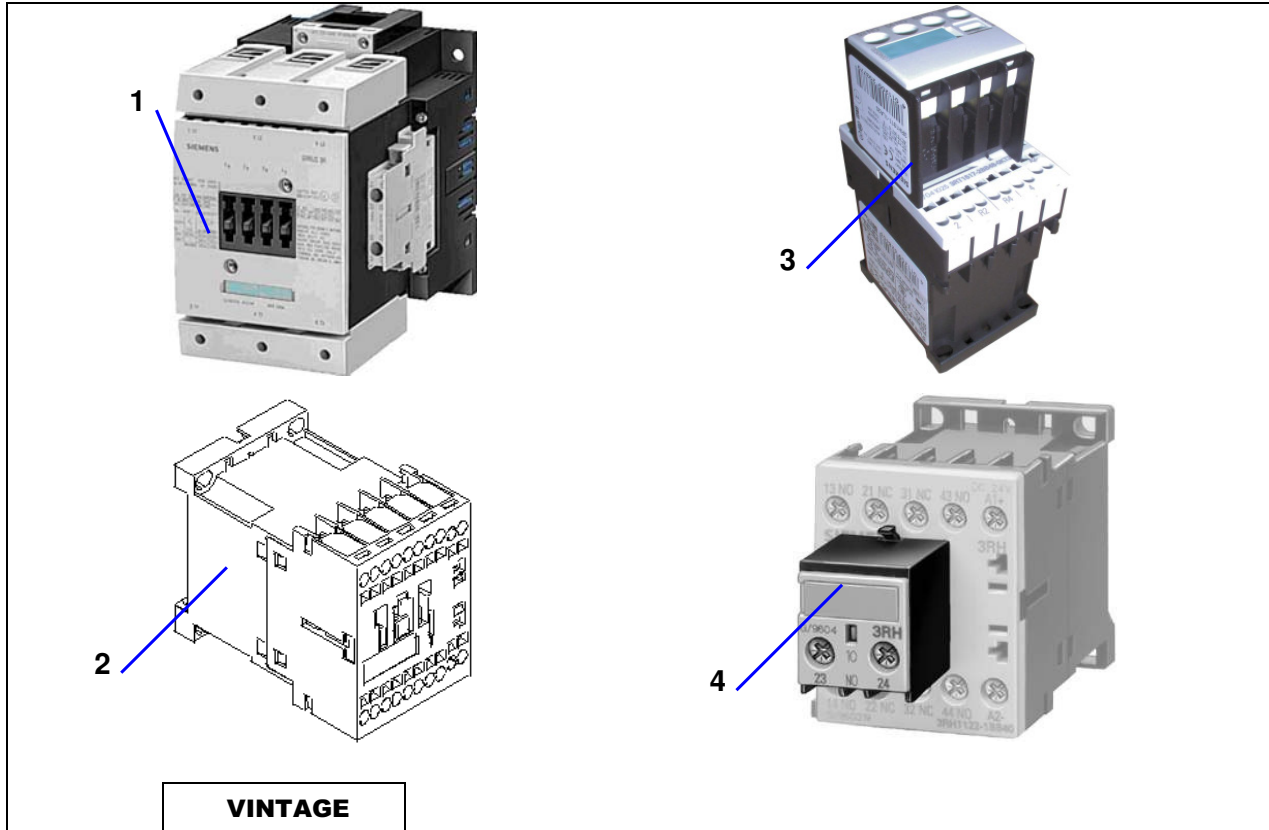

REF. No.	PART No.	DESCRIPTION					RATED POWER AT 400 VAC
		TYPE	RATED COIL VOLTAGE	CONTACTS			
				NO	NC	MAIN	
1	GAA638EG1	3RT1054	220-240V 40-60Hz & DC	2	2	3	55 kW
	GAA638EH 1	3RT1055					75 kW
	GAA638EJ1	3RT1056					90 kW
2	GAA638FB1	3RT1316	110 VAC	-	-	4	3 kW
	GAA638FB2		48 VDC				
	GAA638FF1	3RT1017	24 VDC	0	1	3	5,5 kW
3	GAA638FD1	3RT1517	24 VDC	2	0	2 NO 2 NC	5,5 kW
	GAA638FD2		24 VDC	2	2		
	GAA638FD3		110V; 50/60 Hz	0	0		
	GAA638FD4		24 VDC	3	1		
4	GAA638FH1	3RT1015	110V; 50/60 Hz		2	3	3,3 kW
	GAA638FJ1	3RT1017	24 VDC		2	3	3,3 kW
-	GAA638GA1	3RT1026	24 VDC	1	1	3	11 kW

CONTROLLER PART MAIN SWITCH & RELAY SIEMENS (SIRIUS 3R)

10-GAA613GL-GN

RELAY (1)

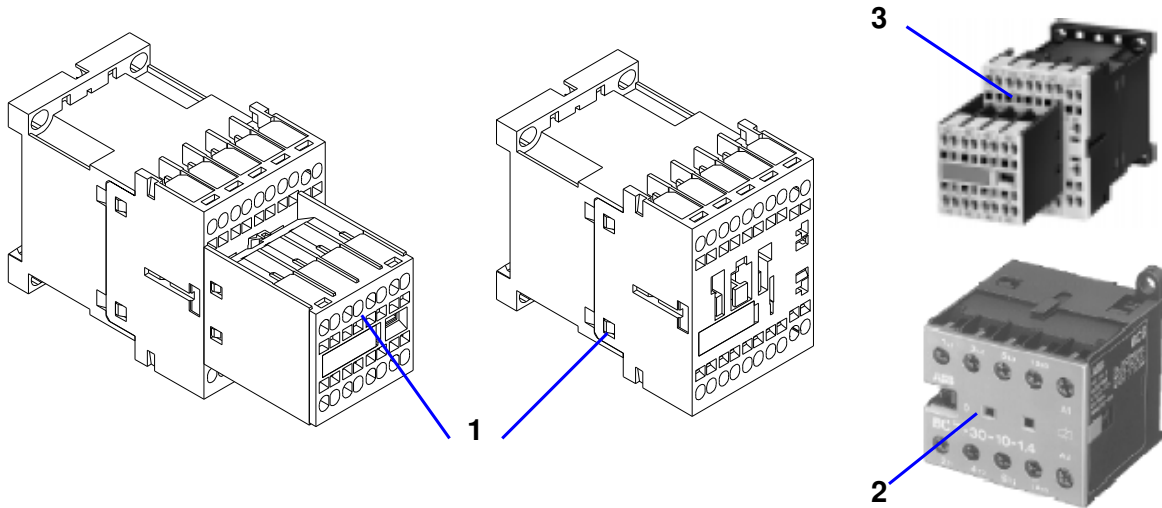

REF. No.	VINTAGE	DESCRIPTION						
	PART No.	TYPE	RATED COIL VOLTAGE	CONTACTS		RATED CURRENT AT 400 VAC		
				NO	NC			
1	GAA613HS1	3RH1380	110V; 50/60Hz	8	-	3,0 A		
	GAA613GL3	3RH1362		6	2			
	GAA613GL4	3RH1344	220V; 50/60Hz	4	4			
	GAA613GY1		30VDC					
	GAA613GZ3		48VDC					
	GAA613GZ1		24VDC					
	GAA613GZ2	3RH1362	48VDC	6	2			
	GAA613HD2		30VDC					
	GAA613HD1		110V; 60Hz					
	GAA613HD3	3RH1344		4	4			
	2	GAA613JH1	GJH 1211001 R8224	110V, 40-450Hz	2		2	
		GAA329AS1	DUST COVER					
3	GAA613GN1	3RH1131- 2BB40	24VDC	3	1			

10-GAA613GL-GN

CONTROLLER PART MAIN SWITCH & RELAY SIEMENS (SIRIUS 3R)

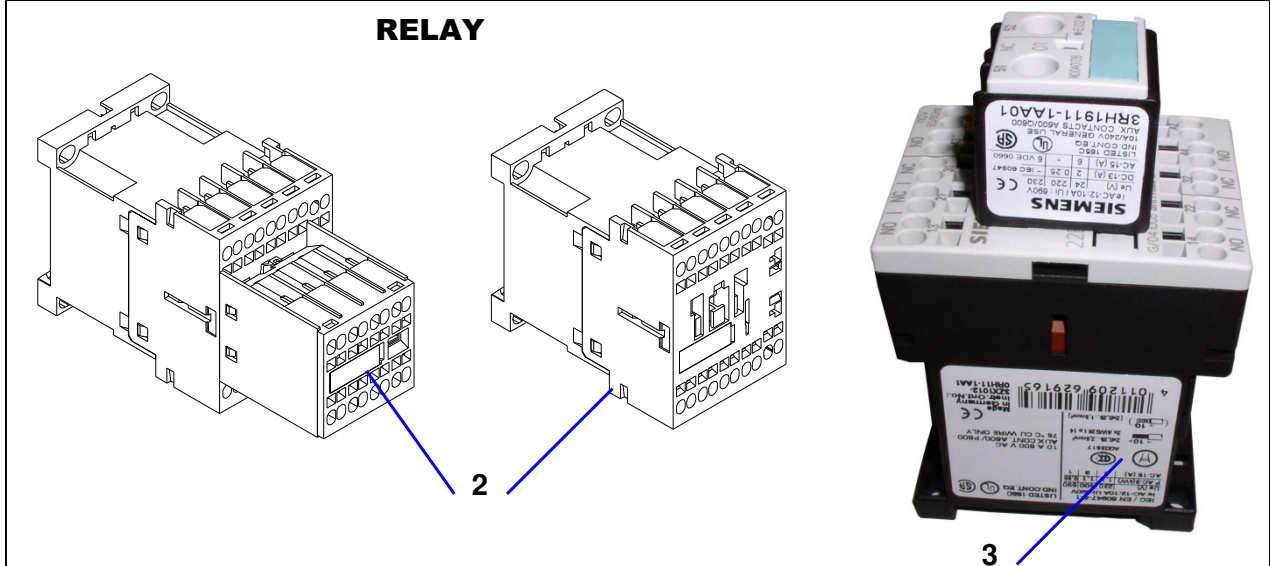

⊗) = WITH RECTIFIER

REF. No.	PART No.	DESCRIPTION				RATED CURRENT AT 400 VAC
		TYPE	RATED COIL VOLTAGE	CONTACTS		
				NO	NC	
2	GAA613GM1 *	3RH1140	110V; 50/60Hz	4	-	3,0 A
	GAA613GM2 *	3RH1122		2	2	
	GAA613GT1 *	3RH1131	110V; 60Hz 24VDC 110VDC	3	1	
	GAA613GT2 *					
	GAA613GN1 *					
	GAA613GV1 *	3RH1122	230V; 50/60Hz 110V; 60Hz 24VDC 48VDC	2	2	
	GAA613GR1 *					
	GAA613GR2 *					
	GAA613GS2 *					
	GAA613GS1 *	3RH1140	110 V ; 50/60 Hz	4	-	
	GAA613GN2 *					
	GAA613HR1 *	3RH1122	110 V ; 50/60 Hz ⊗)	2	2	
	GAA613HR2 *	3RH1131		3	1	
GAA613HR3 *	3RH1140	4		-		
3	GAA613GM3 *	3RT1823	110V; 50/60Hz	2	3	

CONTROLLER PART MAIN SWITCH & RELAY SIEMENS (SIRIUS 3R)

10-GAA613GL-GN

RELAY WITH MECH. LATCHING



INTERFACE RELAY

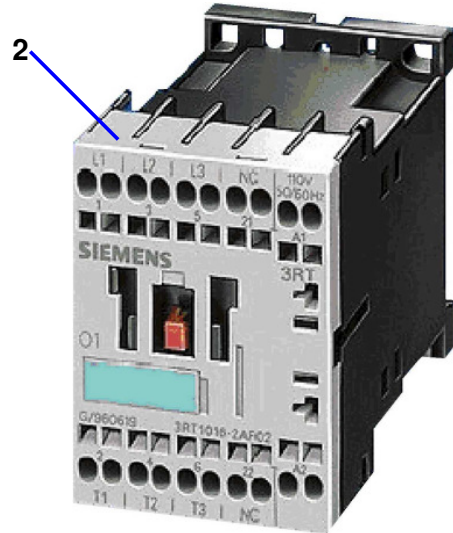

REF. No.	VINTAGE		DESCRIPTION			
	PART No.	TYPE	RATED COIL VOLTAGE	CONTACTS		RATED CURRENT AT 400 VAC
				NO	NC	
1	GAA613HF1 *	3RH1453	230 V ; 50/60 Hz	5	3	3,0 A
2	GAA613HN1 *	3RH1122	24VDC; 1.4W W Diode	2	2	
	GAA613HN2 *					
	GAA613HE4 *	3RH1131	24VDC; 2.3W	3	1	
	GAA613HE1 *	3RH1122	30VDC ± 30 %	2	2	
	GAA613HE2 *	3RH1131		3	1	
	GAA613HE3 *	3RH1140		4	-	

10-GAA613GL-GN

**CONTROLLER PART MAIN
SWITCH & RELAY SIEMENS
(SIRIUS 3R)**

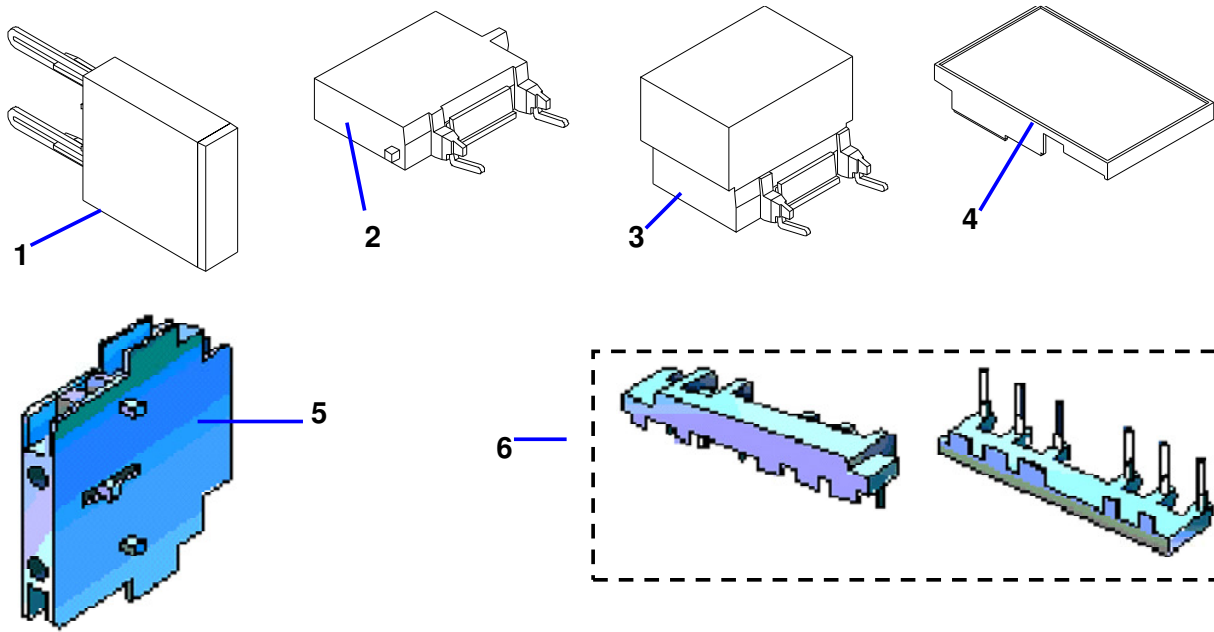

VINTAGE			
REF. No.	PART No.	RATED COIL VOLTAGE	DESCRIPTION
1	GAA605H12	48-127 VAC 70-150 VDC	RC-NETWORK
2	GAA605H13		
3	GAA605H14		
1	GAA605H18	127-240 VAC 150-250 VDC	
2	GAA605H19		
3	GAA605H20		
1	GAA605H15	12-250 VDC	DIODE (INTERFERENCE SUPPRESSOR)
	GAA605H16		DIODE & Z-DIODE COMBINATION (SHORT FALL DELAY TIME)
2	GAA605H17	30-250 VDC	
1	GAA605H22	180-255 VAC	OVERVOLTAGE SUPPRESSOR
	GAA605H24	DC 24V	Diode assembly
2	GAA605H25	48-127 VAC 70-150 VDC	Varistor
3	GAA605H26		Varistor
4	GAA329AL1	DUST CAP	
5	GAA638EP3	INTERLOCK	
6	GAA638EP1	USED FOR 3RT102...	SET OF BRIDGES
	GAA638EP2	USED FOR 3RT103...	