

# SPL 10-YX9707S - NAO 506SL Escalator, Electronic Controller Control Cabinet

Unpublished Work - © Otis Elevator Company. Any unauthorized reproduction, disclosure, or distribution of copies or content by any person of any portion of this work may be a violation of Copyright Law of the United States of America. All rights reserved.

February 1991

Page 1

10	YX9707S	
Y	VINTAGE	G 01
REV.	EN	

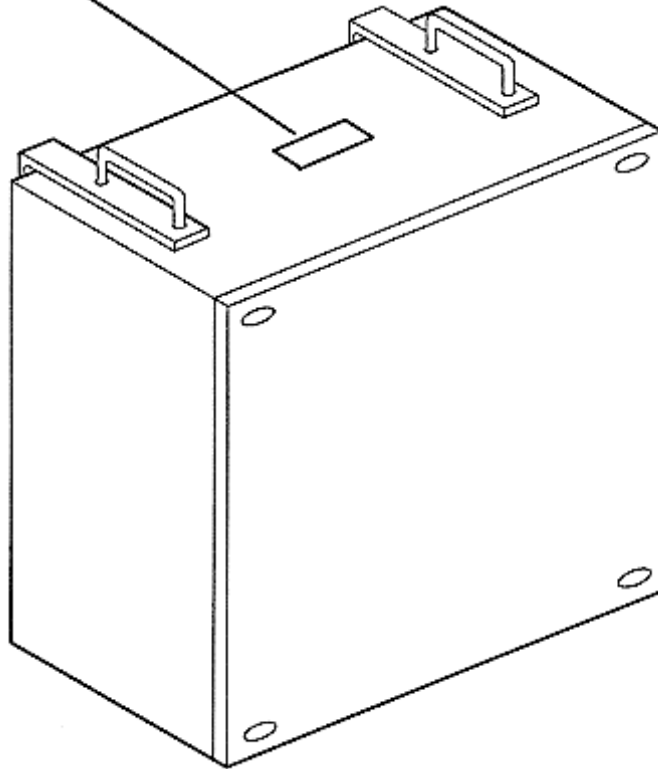

SPL 10-YX9707S - NAO 506SL Escalator, Electronic Controller Control Cabinet

Page 2 - NAO 506SL ELECTRONIC CONTROLLER CONTROL CABINET

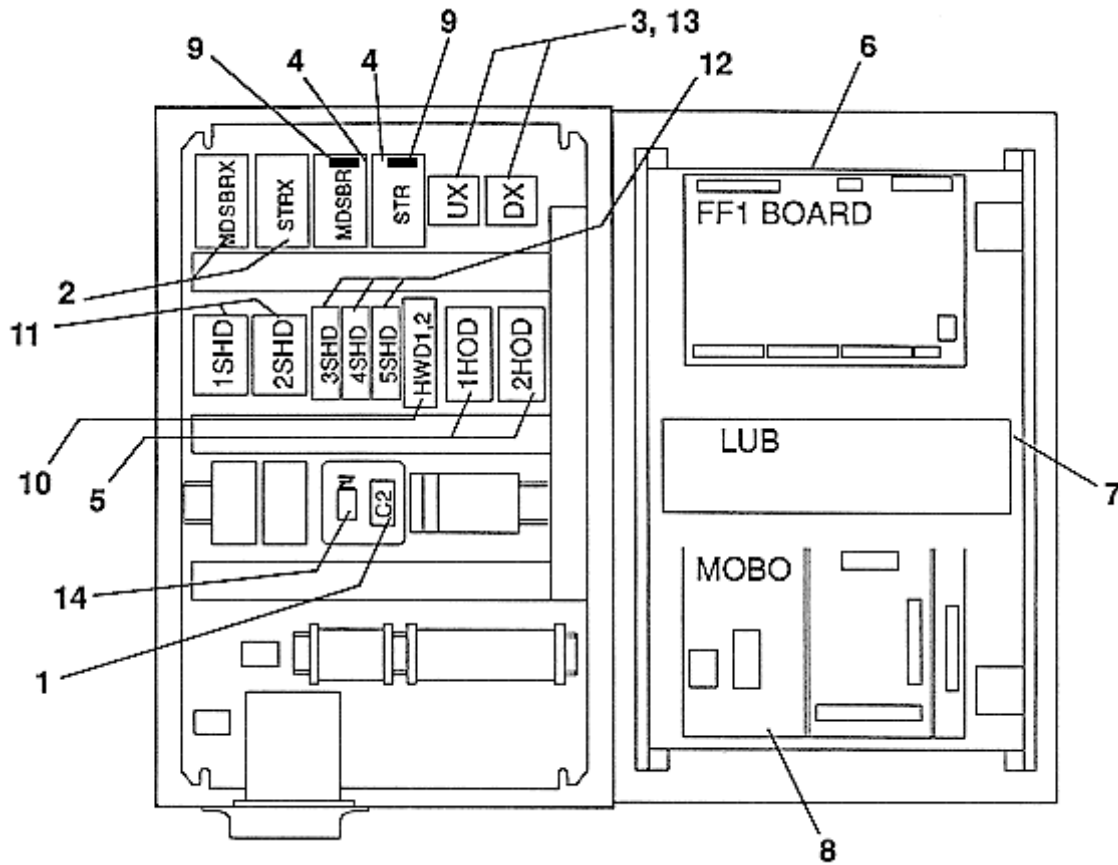

VINTAGE G.01			
REF. NO.	PART OR ML	DESCRIPTION	POSITION
1	GO226T205	Capacitor, 2200MF, 40VDC	C2
2	GO613CK220	Contactory Relay	MDSBRX, STRX
3	GO613CE402	Contactory Relay	UX, DX
4	GO613AN2210	Contactory Relay	MDSBR, STR
5	GO613CM1	Control Device	1HOD, 2HOD
6	A9707A1	Fault Finder PCB	FF1
7	9707G1	LUB PC Board	LUB
8	A9707C1	Motherboard PCB	MOBO
9	GO634B6	RC-Element for 3TH80	MDSBR, STR
10	GO613CL1	Relay	HWD1, HWD2
11	GO630D1	Speed Governor	1SHD, 2SHD
12	GO613CJ1	Time Relay	SHD3, 4, 5
13	GO604A1	Varistor for 3TH20	UX, DX
14	GO606J1	Z-Diode	Z

SPL 10-YX9707S - NAO 506SL Escalator, Electronic Controller Control Cabinet

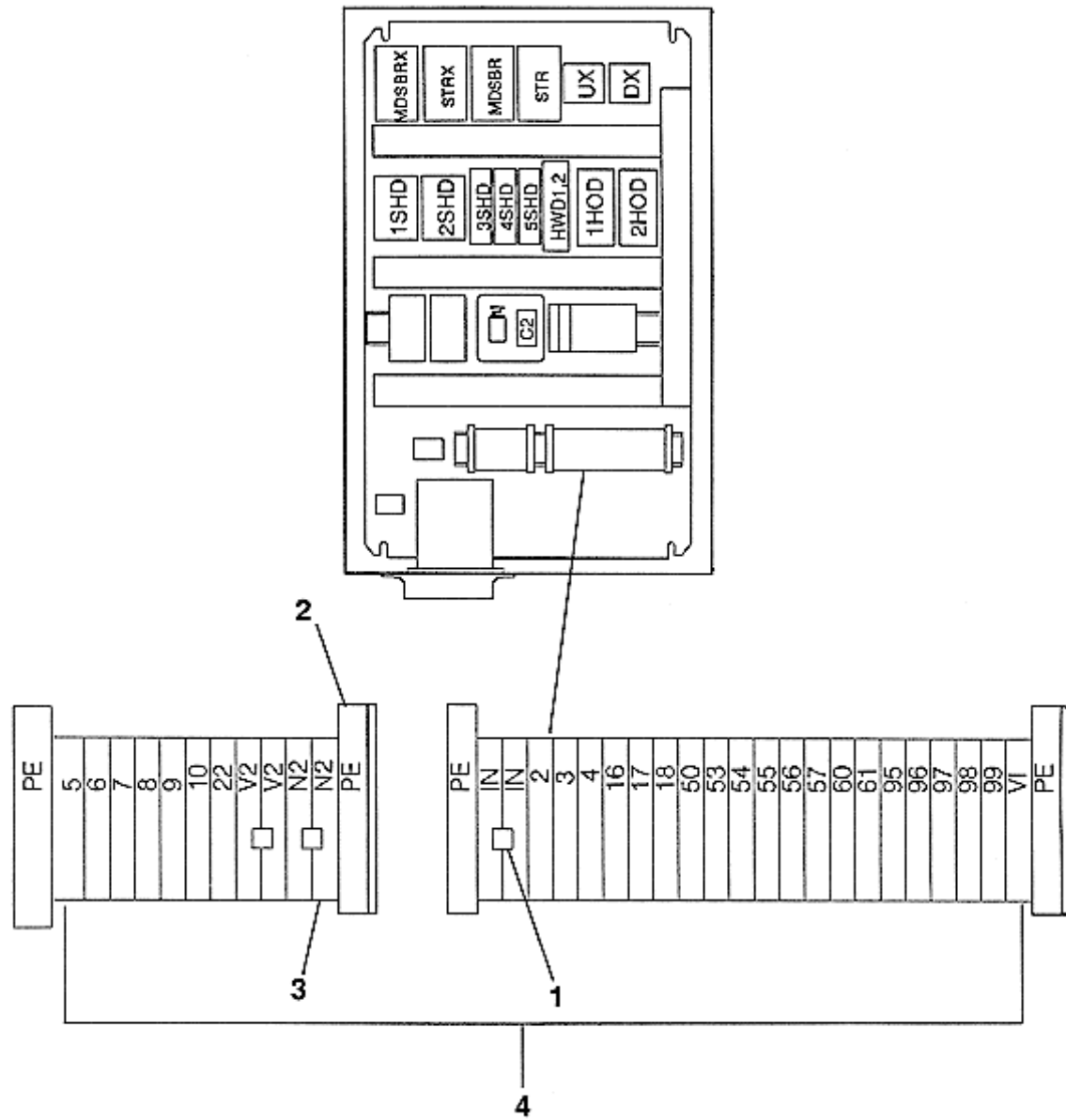

VINTAGE G.01		
REF. NO.	PART OR ML	DESCRIPTION
1	GO190DK4	Bar, Jumper, 2-Terminal
2	GO190DM1	Terminal Block, Ground
3	GO190DK2	Terminal Block, Modular (Blue)
4	GO190DK1	Terminal Block Modular (Gray)