

# Car Components

**Spare Parts Leaflet**

**14-AAA25400AL**

**July 21, 2010 / Page 1 of 3**

**W/O  
VINTAGE**

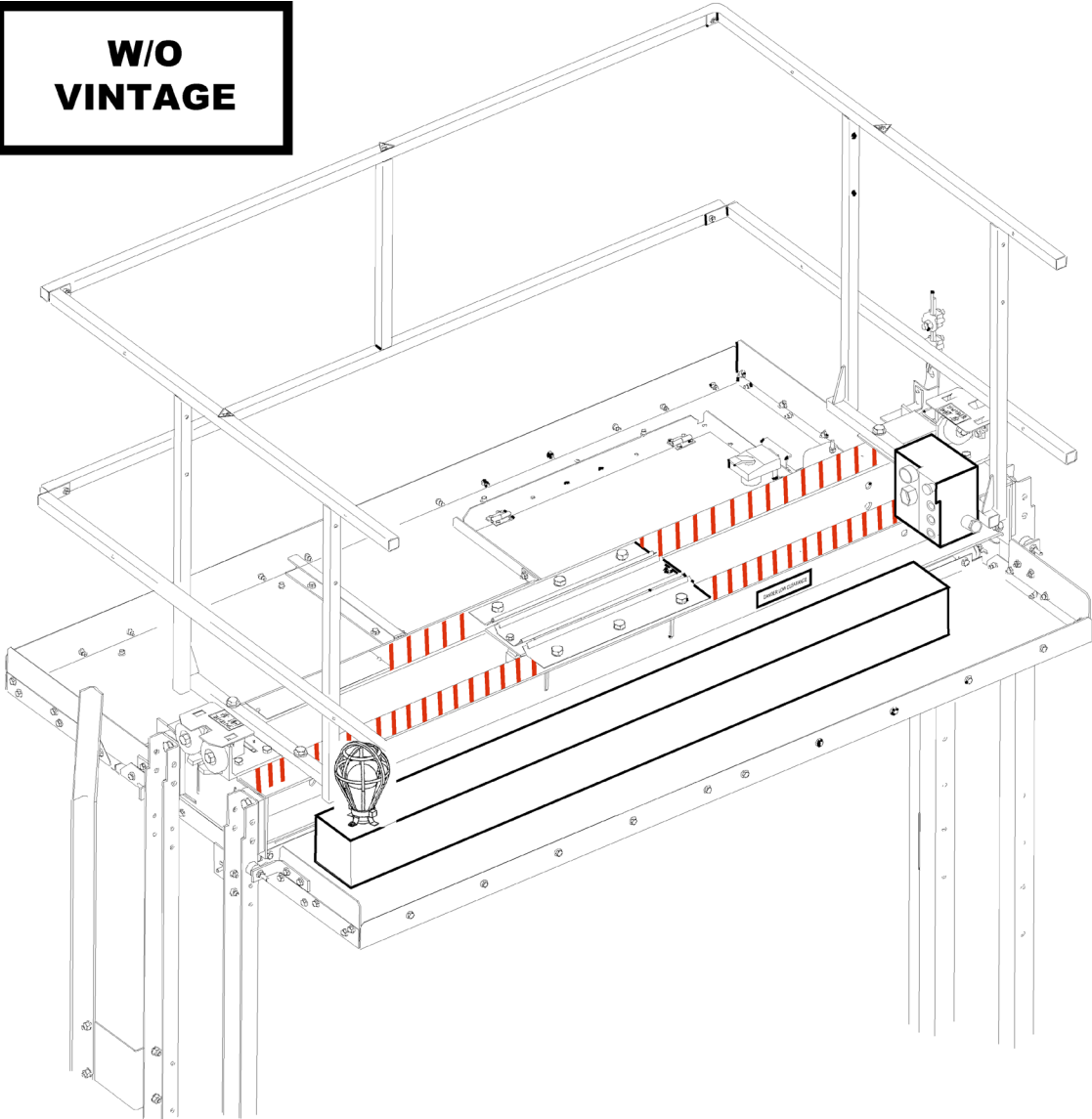

Unpublished Work—© Otis Elevator Co., 2010

**OTIS**

**Safety First!**

**SERVICE ENGINEERING**  
**Otis Elevator Company**  
**Bloomfield, Connecticut**  
**USA**

**Leaflet Description**

This leaflet provides spare part information for the top of car electrical components used in the 953Kg and 1134Kg duty Gen2 elevators for A17.1-2000 applications.

**Leaflet Revisions**

<b>Date Revised</b>	<b>Subject Matter Expert</b>	<b>Reason for Revision</b>
February 3, 2004	Dave Gallahue	New SPL.
July 21, 2010	Troy Chicoine	Removed reference to SPL 14-M**24831A on p. 3 and included p/n MBA24831A001 instead

**Related Drawings**

<b>Drawing No.</b>	<b>Title</b>	<b>Drawing No.</b>	<b>Title</b>
AAA25400AL	Car Component and Wiring Layout Gen2 Limited Release	FAA24011Z	Carframe, Platform, Ceiling, and Balustrade
AAA24831H	Top of Car Inspection Box Pluggable Gen2	AAA25580AS	Integrated Top of Car Box

**Related Documents**

<b>Document ID</b>	<b>Title</b>
SPL 14-F..24011Z	Assembly Carframe & Platform for NAA
SPL 17-AAA25580AS	Top-of-Car Integration Box for Gen2™ Systems

**Subject Matter Expert**

<b>Name</b>	<b>Department</b>
Troy Chicoine	OSC Service Engineering

**About Spare Parts Leaflets...**

This document lists the lowest replaceable units (LRUs) for the standard version of the product. The LRUs are chosen by a team of Otis associates representing engineering and manufacturing.

While goal of this document is to make parts identification as easy as possible, the document cannot be all-inclusive. Elevator and escalator contracts classified as "special" or "custom" are not addressed here. For such contracts, please refer to specified information, the contract folder, TIPs, Field Education Articles, Construction Letters, etc. for further information.

If you have any suggestions about this document, please contact the subject matter expert listed on this page.

# Carframe Components

**14-AAA25400AL**

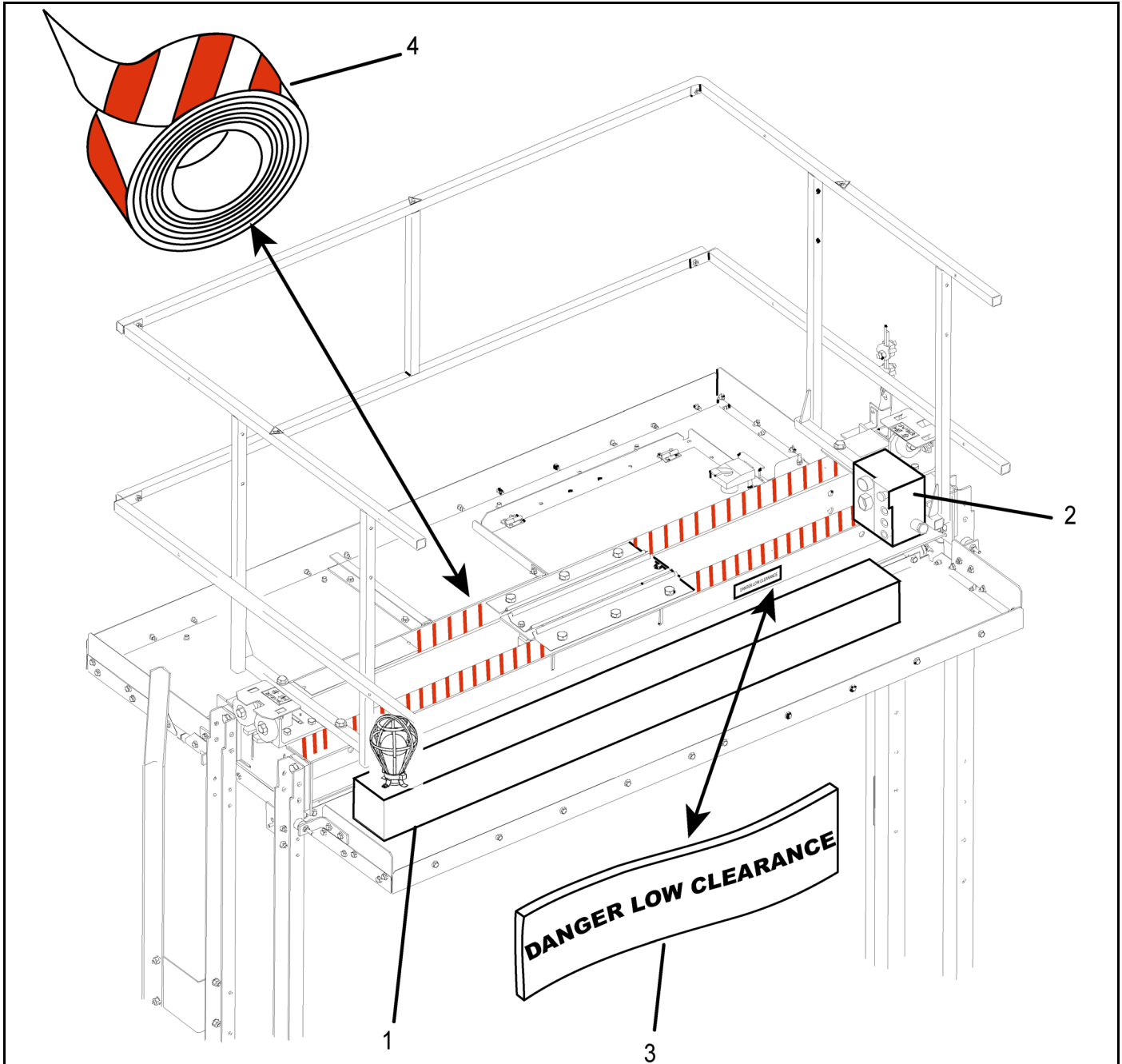

W/O VINTAGE		
REF. No.	PART No.	DESCRIPTION
1	---	Assembly, Integrated Top-of-Car Box,  SPL 17-AAA25580AS
2	MBA24831A001	Assembly, Top-of-Car Inspection Box
3	AAA102ALY1	Label, with Adhesive Backing, 50 x 150 mm, "Danger Low Clearance"
4	AAA297BA3	Tape, Striped Safety Hazard, with Adhesive Backing, Red and White Striped, 4.0 in. Wide x 7 Yards Long Roll