

**Miscellaneous
Top-of-Car Components
GEN2**

**Spare Parts Leaflet
14-AAA25400AV
July 21, 2010 / Page 1 of 3**

**W/O
VINTAGE**

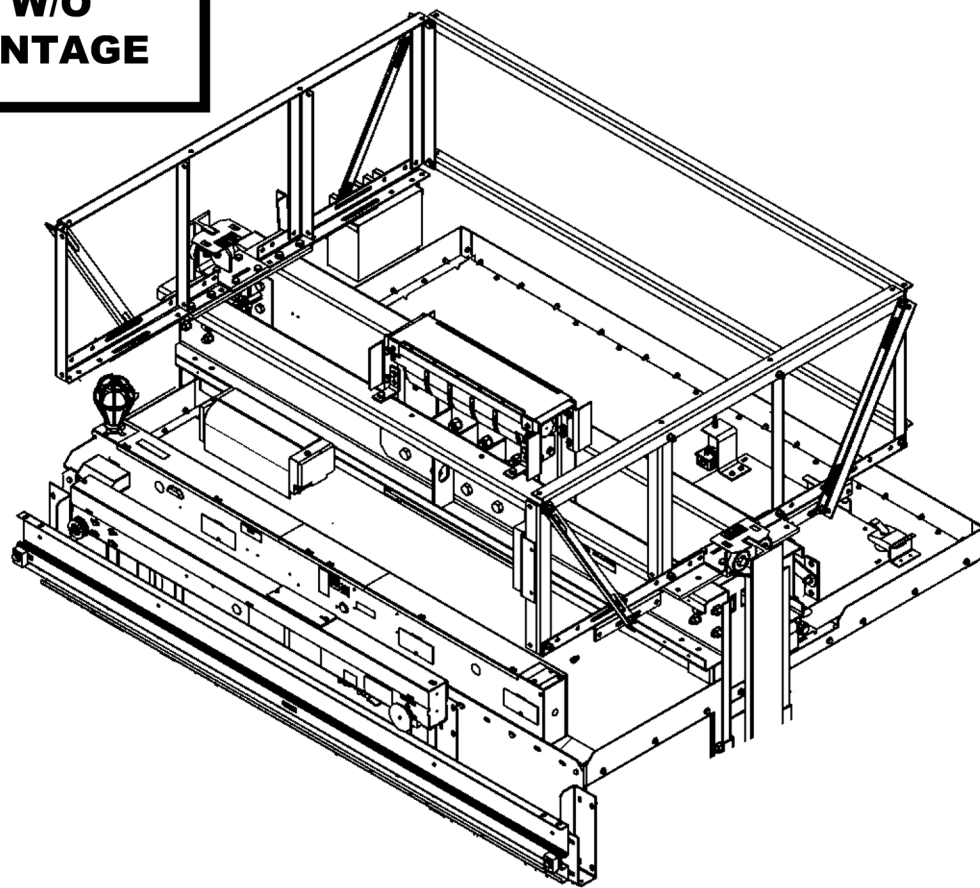

Unpublished Work—© Otis Elevator Co.; 2010

OTIS

Safety First!

**SERVICE ENGINEERING
Otis Elevator Company
Bloomfield, Connecticut
USA**

Leaflet Description

This leaflet describes car components spare parts information for the Gen2 Extended Duty elevator system.

Leaflet Revisions

Date Revised	Subject Matter Expert	Reason for Revision
January 27, 2004	Brian Mierzejewski	New SPL.
July 21, 2010	Troy Chicoine	Removed reference to SPL 14-M**24831A on p. 3 and included p/n MBA24831A001 instead

Related Drawings

Drawing No.	Title	Drawing No.	Title
AAA25400AV	Car Component and Wiring Layout Gen2 Extended Duty	FAA24011Z	Carframe, Platform, Ceiling, and Balustrade
AAA24831H	Top of Car Inspection Box Pluggable Gen2	AAA25580AS	Integrated Top of Car Box
AAA29000AD	Gen2 Extended Duty System Drawing		

Related Documents

Document ID	Title
SPL 17-AAA25580AS	Top-of-Car Integration Box for Gen2™ Systems
SPL 14-M...24831A	Top-of-Car Inspection Box

Subject Matter Expert

Name	Department
Troy Chicoine	OSC Service Engineering

About Spare Parts Leaflets...

This document lists the lowest replaceable units (LRUs) for the standard version of the product. The LRUs are chosen by a team of Otis associates representing engineering and manufacturing.

While goal of this document is to make parts identification as easy as possible, the document cannot be all-inclusive. Elevator and escalator contracts classified as "special" or "custom" are not addressed here. For such contracts, please refer to specified information, the contract folder, TIPs, Field Education Articles, Construction Letters, etc. for further information.

If you have any suggestions about this document, please contact the subject matter expert listed on this page.

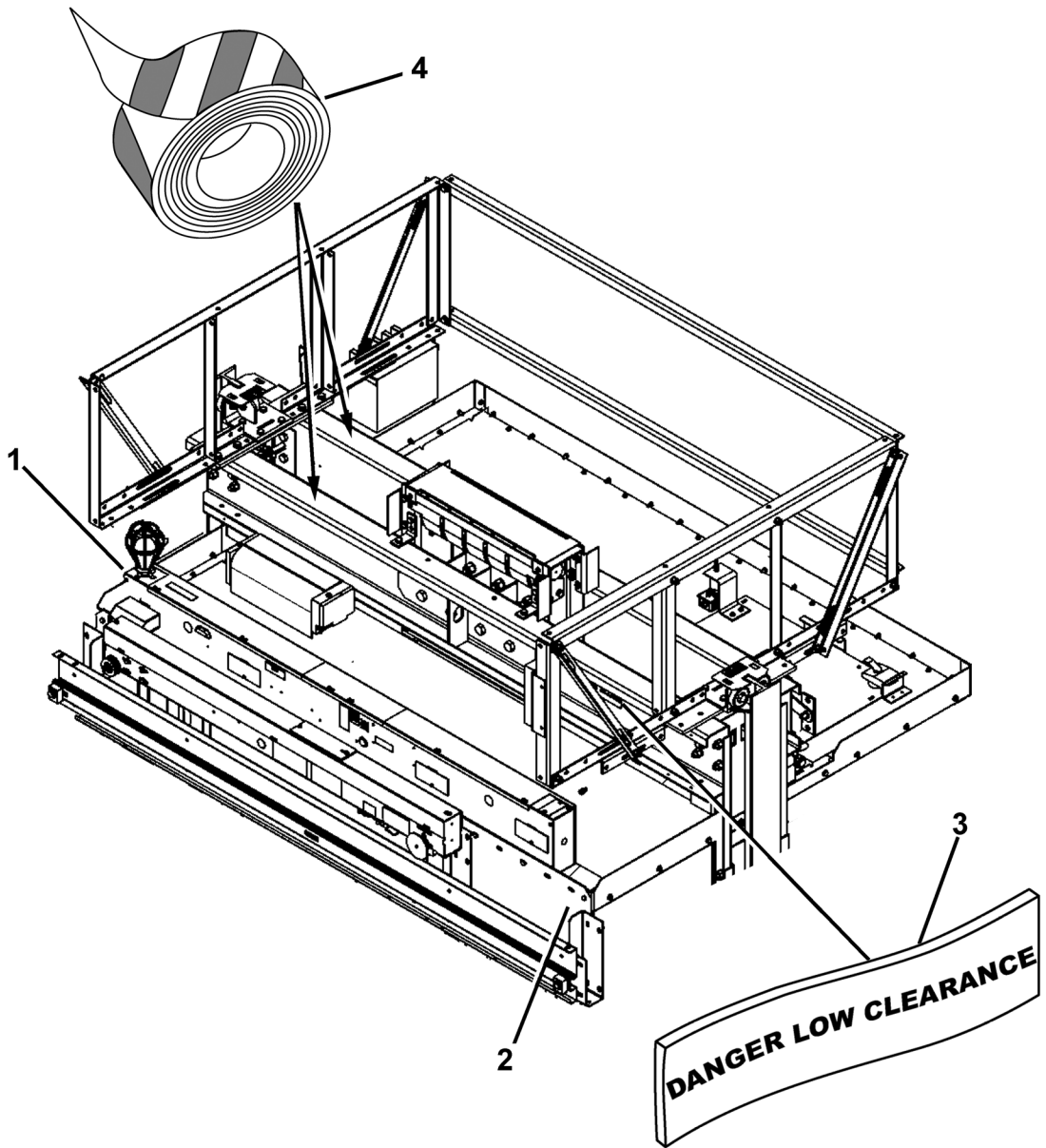

REF. No.	W/O VINTAGE PART No.	DESCRIPTION
1	---	Assembly, Integrated Top-of-Car Box,  SPL 17-AAA25580AS
*2	MBA24831A001	Assembly, Top-of-Car Inspection Box
3	AAA102ALY1	Label, with Adhesive Backing, 50 x 150 mm, "Danger Low Clearance"
4	AAA297BA3	Tape, Striped Safety Hazard, with Adhesive Backing, Red and White Striped, 4.0 in. Wide x 7 Yards Long Roll
**5	AAA512A400	Telephone and Accessories Intercom

* General location, part not shown.

** Part not shown.