

**Miscellaneous
Top-of-Car Components
Gen2 ED w/ Side CWT**

Spare Parts Leaflet

14-AAA25400AZ

August 10, 2011 / Page 1 of 4

**W/O
VINTAGE**

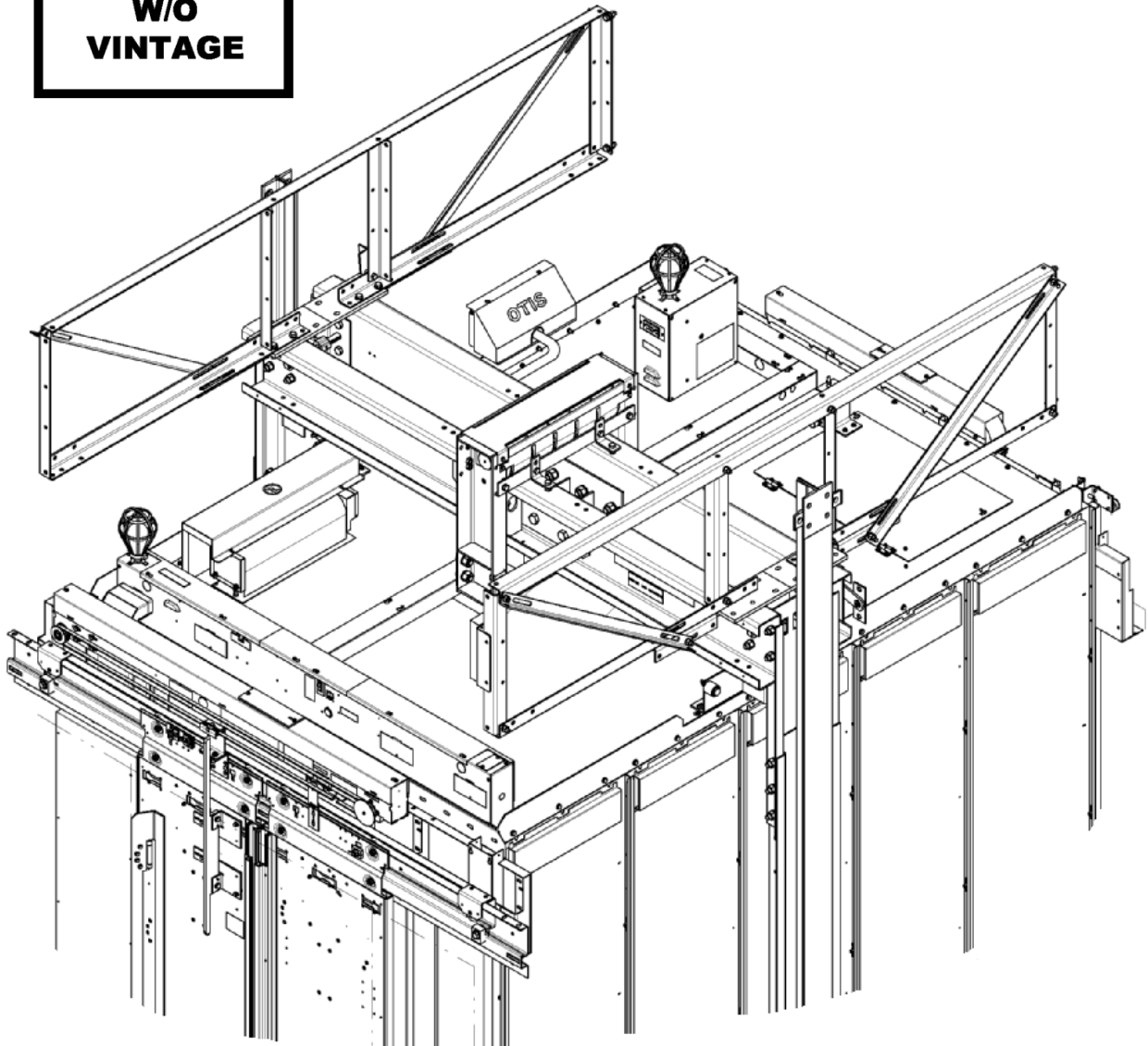

Unpublished Work—© Otis Elevator Co.; 2011

OTIS

Safety First!

SERVICE ENGINEERING
Otis Elevator Company
Bloomfield, Connecticut
USA

Leaflet Description

This leaflet describes top of car components spare parts information for the Gen2® elevator system.

Leaflet Revisions

Date Revised	Subject Matter Expert	Reason for Revision
August 10, 2011	Troy Chicoine	New SPL.

Related Drawings

Drawing No.	Title	Drawing No.	Title
AAA25400AZ	Car Component and Wiring Layout Gen2® ED Side CWT	AAA29000AJ	Gen2® System Level Drawing
AAA24831H	Top of Car Inspection Box Pluggable Gen2	AAA25580AS	Front Top Of Car Integration Box GCS/Gen2® - RSL
AAA24000BK	Arr. & Assy. Gen2® Carframe & Platform	AAA25580AT	Assy. & Arr. Rear Top Of Car Integration Box w/ 30VDC Lambda GCS/Gen2® - RSL

Related Documents

Document ID	Title
SPL 14-AAA24831H	Top-Of-Car Inspection Box (Pluggable)
SPL 17-AAA25580AS	Top-Of-Car Integration Box for Gen2® Systems
SPL 17-AAA25580AT	Rear Top-Of-Car Integration Box (w/ Internal Door Detector)

Subject Matter Expert

Name	Department
Troy Chicoine	Otis Service Center, Bloomfield

About Spare Parts Leaflets...

This document lists the lowest replaceable units (LRUs) for the standard version of the product. The LRUs are chosen by a team of Otis associates representing engineering and manufacturing.

While goal of this document is to make parts identification as easy as possible, the document cannot be all-inclusive. Elevator and escalator contracts classified as "special" or "custom" are not addressed here. For such contracts, please refer to specified information, the contract folder, TIPs, Field Education Articles, Construction Letters, etc. for further information.

If you have any suggestions about this document, please contact the subject matter expert listed on this page.

Car Components

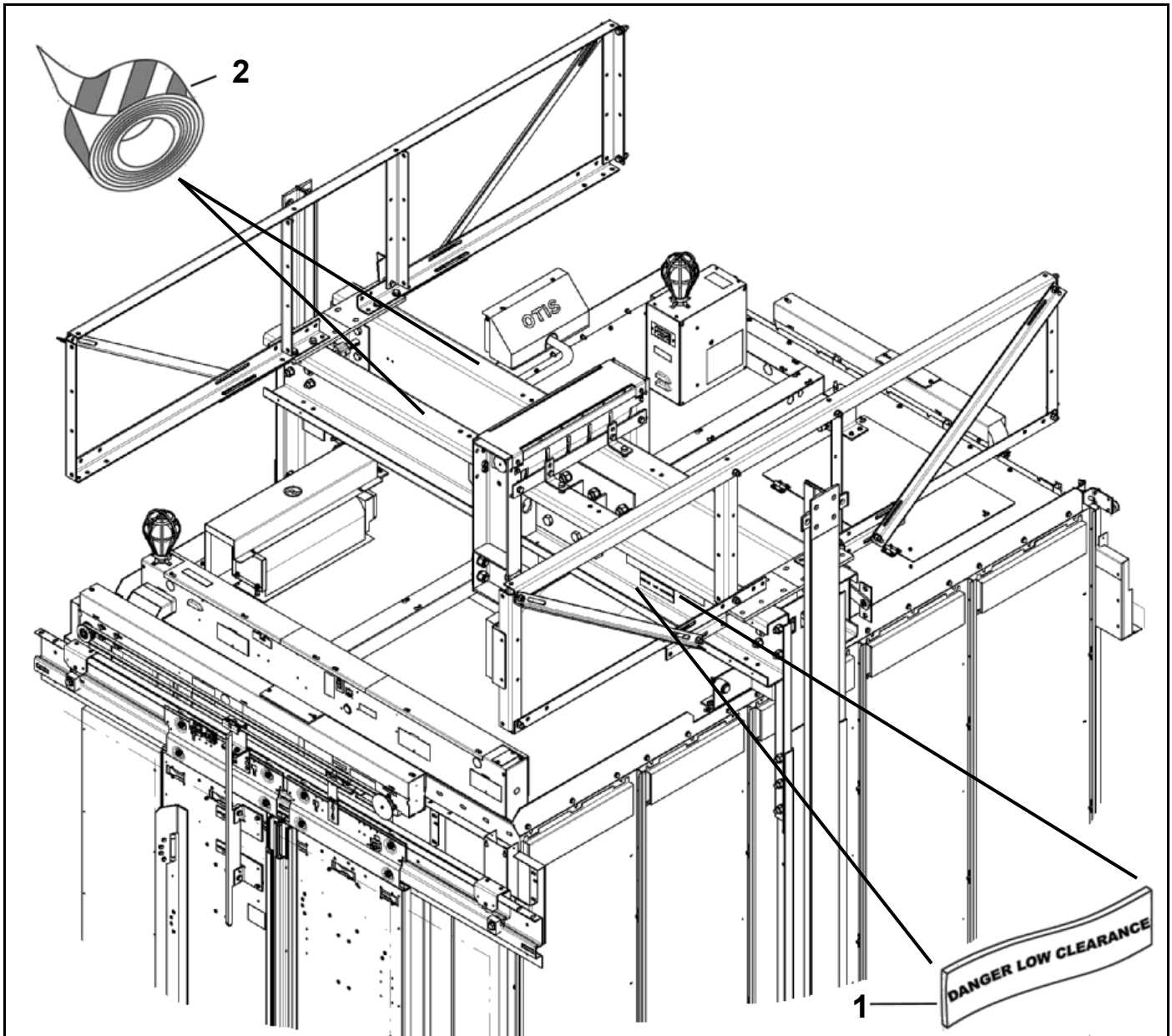

14-AAA25400AZ

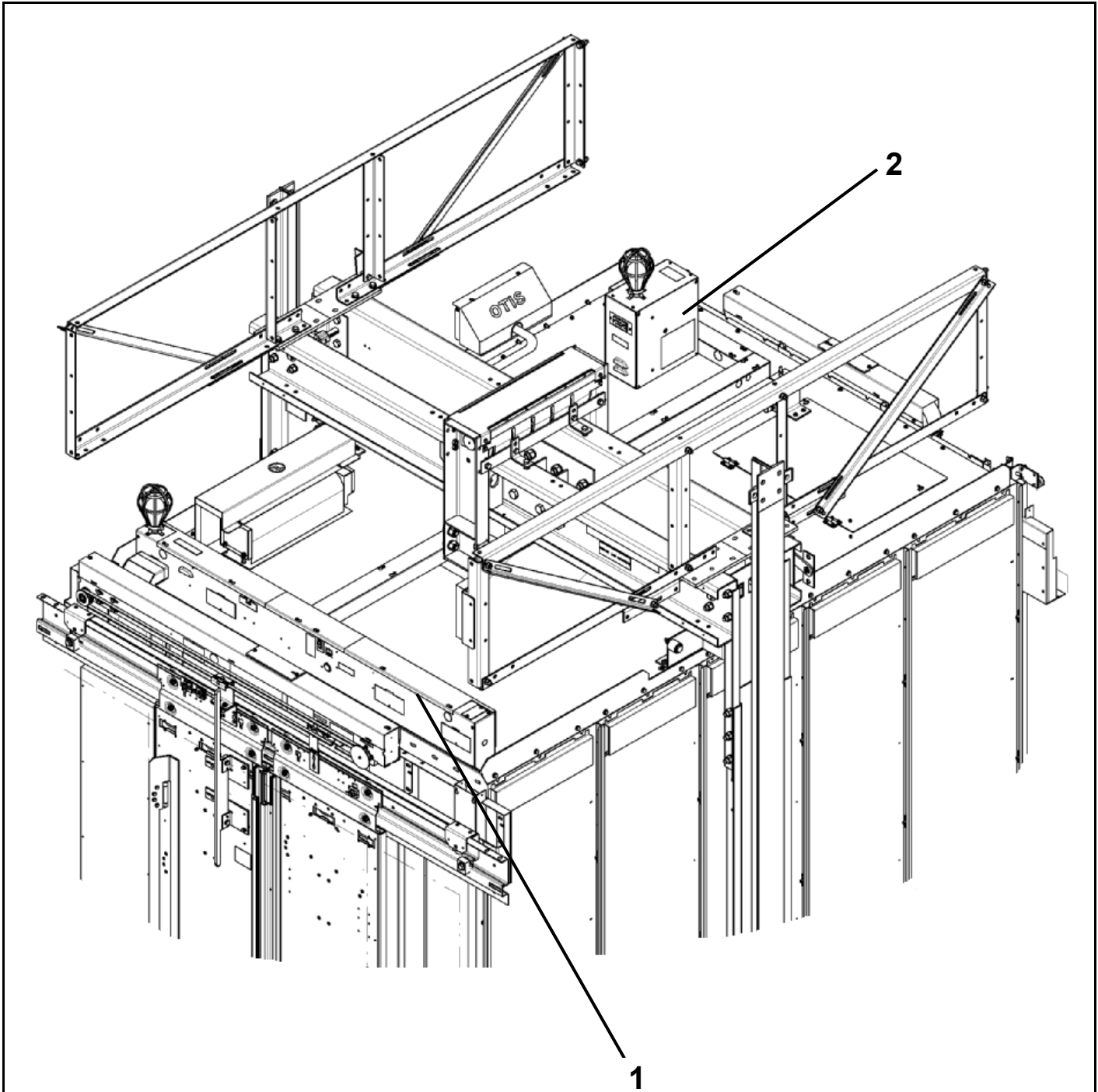

W/O VINTAGE		
REF. No.	PART No.	DESCRIPTION
---	--	Assembly, Top-of-Car Inspection Box,  SPL 14-AAA24831H
1	AAA102ALY1	Label, with Adhesive Backing, 50 x 150 mm, "Danger Low Clearance"
2	AAA297BA3	Tape, Striped Safety Hazard, with Adhesive Backing, Red and White Striped, 4.0 in. Wide x 7 Yards Long Roll
*	AAA512A400	Telephone and Accessories Intercom

* Part not shown, located in cab on structural ceiling above COP.



W/O VINTAGE		
REF. No.	PART No.	DESCRIPTION
1	---	Assembly, Integrated Top-of-Car Box,  SPL 17-AAA25580AS
2	---	Assembly, Rear Integrated Top-of-Car Box,  SPL 17-AAA25580AT