

**Miscellaneous  
Top-of-Car Components  
G2L**

**Spare Parts Leaflet**

**14-AAA25400BK**

**February 10, 2010 / Page 1 of 5**

**W/O  
VINTAGE**

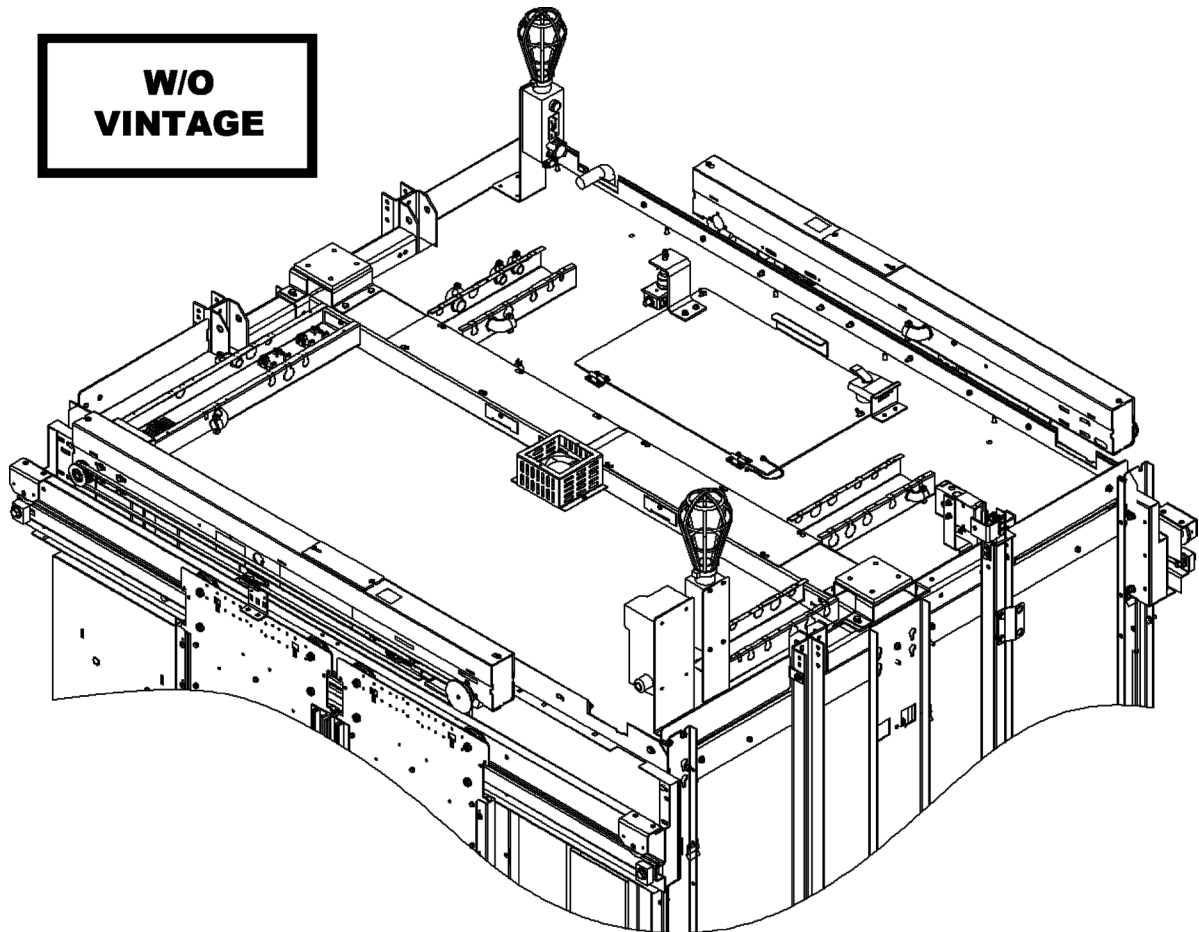

Unpublished Work—© Otis Elevator Co.; 2010

**OTIS**

**Safety First!**

**SERVICE ENGINEERING**  
**Otis Elevator Company**  
**Bloomfield, Connecticut**  
**USA**

**Leaflet Description**

This leaflet describes car components spare parts information for the G2L elevator system.

**Leaflet Revisions**

<b>Date Revised</b>	<b>Subject Matter Expert</b>	<b>Reason for Revision</b>
October 13, 2009	Troy Chicoine	New SPL.
February 10, 2010	Troy Chicoine / Sohaib Shaikh	Added new references 2 and 3 on p 5

**Related Drawings**

<b>Drawing No.</b>	<b>Title</b>	<b>Drawing No.</b>	<b>Title</b>
AAA25400BK	Car Component and Wiring Layout G2L	AAA29000AK	G2L System Level Drawing
AAA24831H	Top of Car Inspection Box Pluggable Gen2	AAA24000CC	Arrangement & Assembly; LCT Carframe, Platform, Ceiling, & Cab Fronts

**Related Documents**

<b>Document ID</b>	<b>Title</b>
SPL 14-AAA24000CC	Arrangement & Assembly; LCT Carframe, Platform, Ceiling, & Cab Fronts
---	---

**Subject Matter Expert**

<b>Name</b>	<b>Department</b>
Troy Chicoine / Sohaib Shaikh	Otis Service Center, Bloomfield

**About Spare Parts Leaflets...**

This document lists the lowest replaceable units (LRUs) for the standard version of the product. The LRUs are chosen by a team of Otis associates representing engineering and manufacturing.

While goal of this document is to make parts identification as easy as possible, the document cannot be all-inclusive. Elevator and escalator contracts classified as "special" or "custom" are not addressed here. For such contracts, please refer to specified information, the contract folder, TIPs, Field Education Articles, Construction Letters, etc. for further information.

If you have any suggestions about this document, please contact the subject matter expert listed on this page.

# Car Components

**14-AAA25400BK**

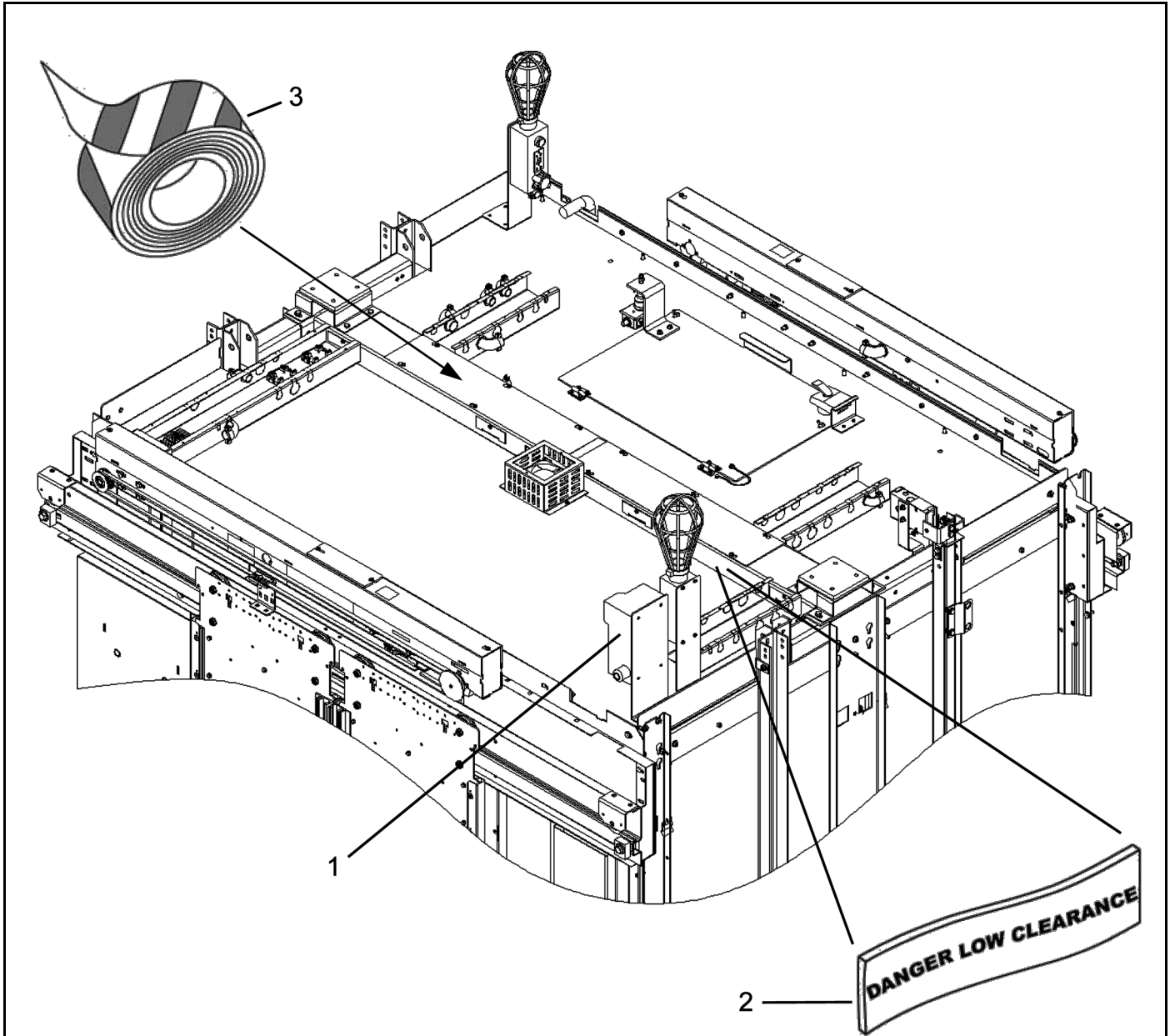

W/O VINTAGE		
REF. No.	PART No.	DESCRIPTION
1	--	Assembly, Top-of-Car Inspection Box,  SPL 14-AAA24831H
2	AAA102ALY1	Label, with Adhesive Backing, 50 x 150 mm, "Danger Low Clearance"
3	AAA297BA3	Tape, Striped Safety Hazard, with Adhesive Backing, Red and White Striped, 4.0 in. Wide x 7 Yards Long Roll
*	AAA512A400	Telephone and Accessories Intercom

\* Part not shown, located in cab on structural ceiling above COP.

**NOTE:** For other car top and cab related components, refer to SPL 14-AAA24000CC.

**Car Components**

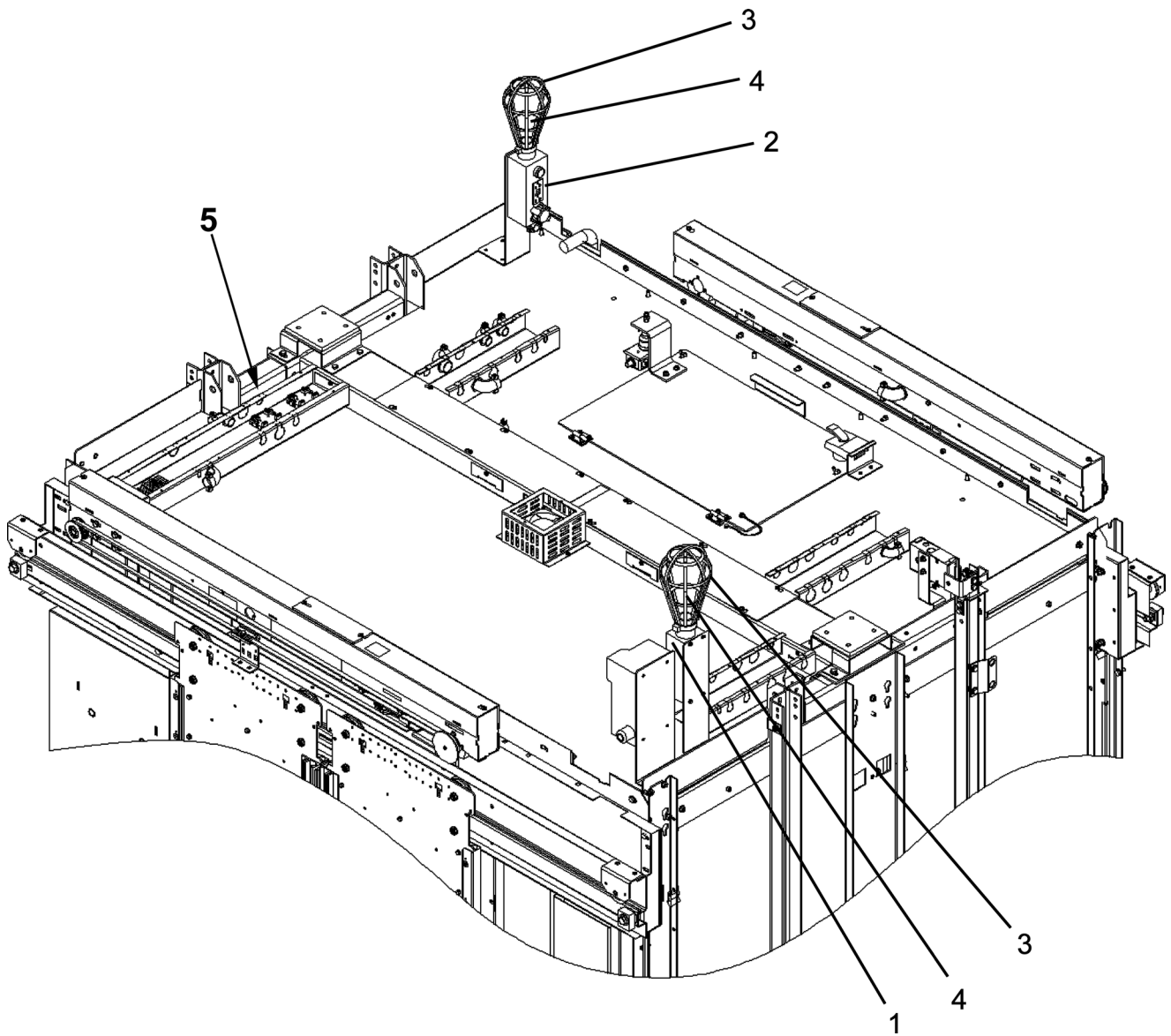

<b>W/O VINTAGE</b>		
<b>REF. No.</b>	<b>PART No.</b>	<b>DESCRIPTION</b>
1	AAA25580BE6	Assembly, TOC Emergency Stop Switch and Light Fixture (w/o Lamp Guard), with GFCI Outlet and Alarm (W → Front Entrance Only)
2	AAA25580BF5	Assembly, TOC Emergency Stop Switch and Light Fixture (w/o Lamp Guard) (W → Rear Entrance Only)
3	AAA384ABX2	Guard, Lamp
4	6599D14	Lamp, 125 VAC, 100 W
5	---	LAMBDA Detector Material See p. 5

# LAMBDA Components

14-AAA25400BK

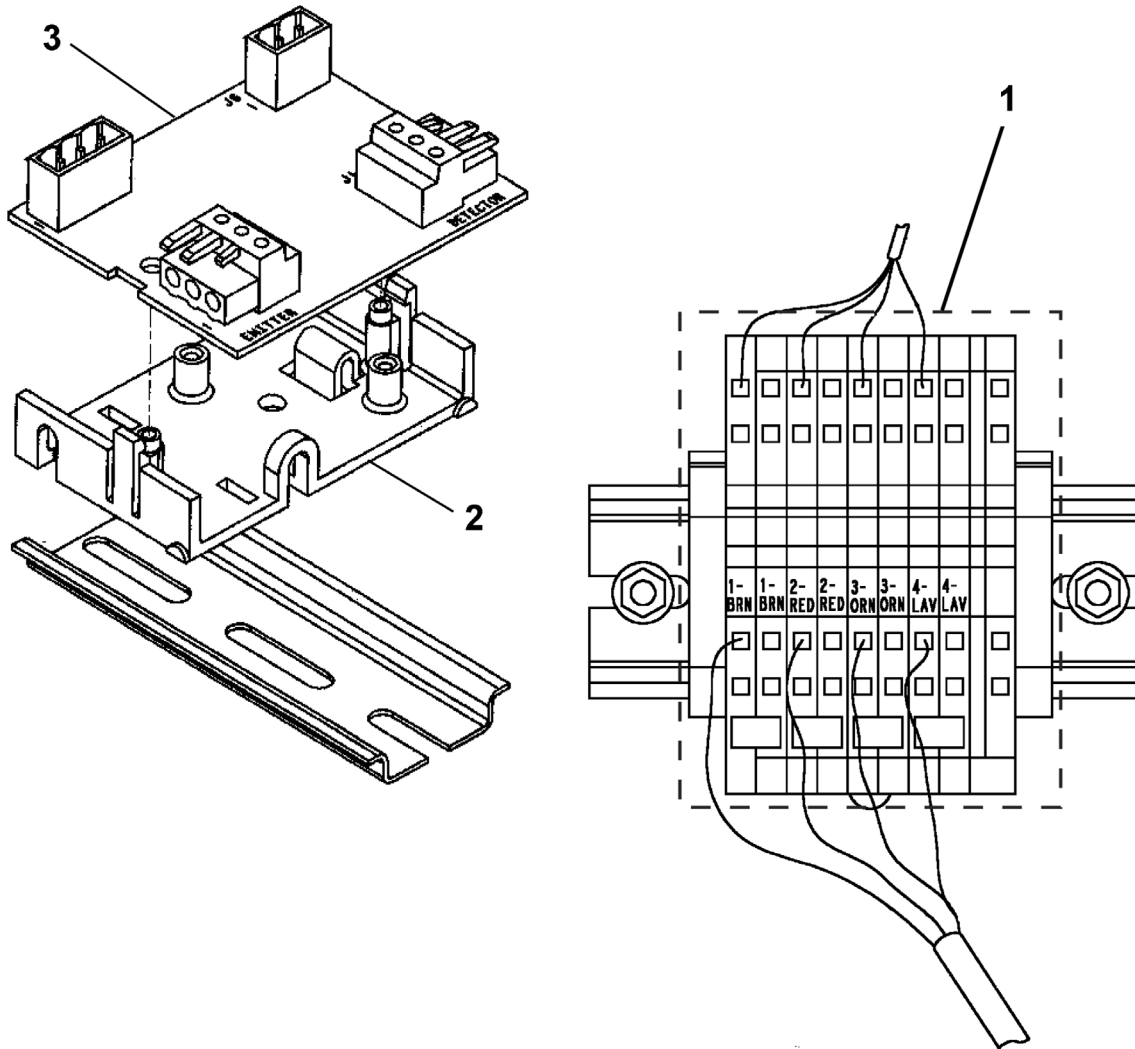

W/O VINTAGE		
REF. No.	PART No.	DESCRIPTION
1	AAA21303CY2	Assembly, Terminal Block
2	AAA180FE1	Holder, Molded
3	AAA26800APY1	Lambda LC PC Board