

OS6000D Safety Gear

Spare Parts Leaflet

14-DAA24120E

February 6, 2018 / Page 1 of 4

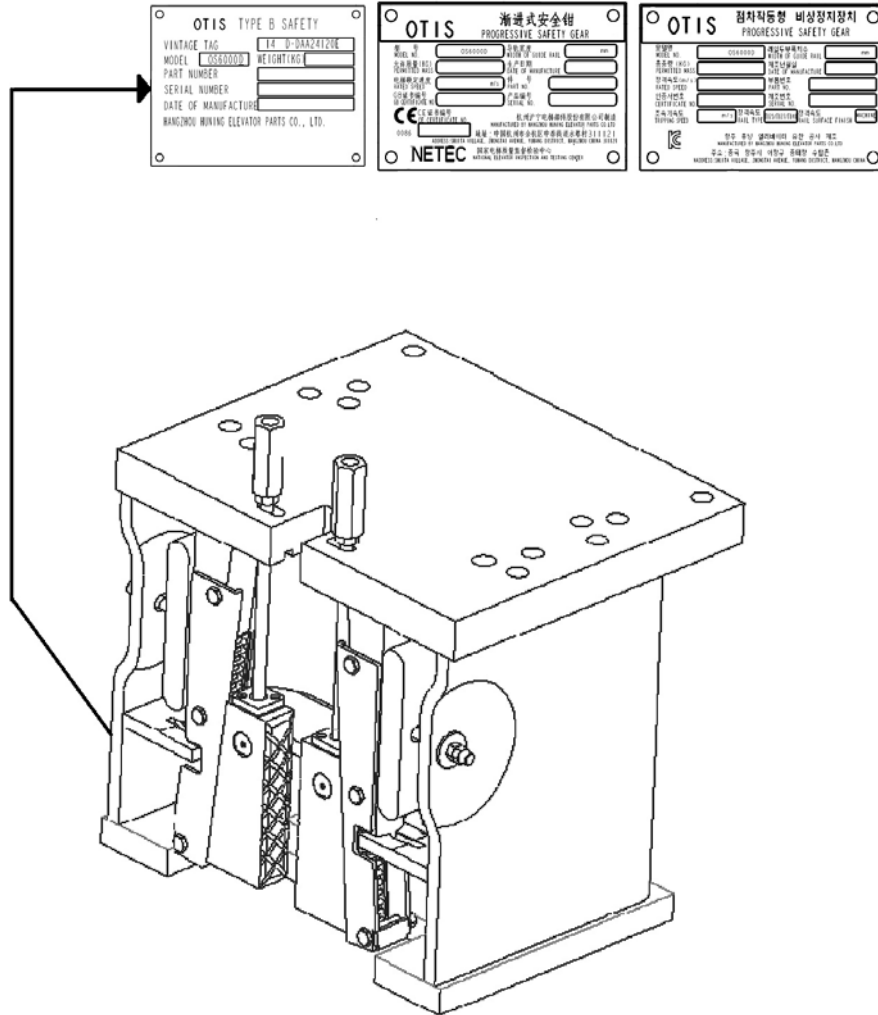

Unpublished Work—© Otis Elevator Co.; 2018



Safety First!

SERVICE ENGINEERING
Otis Elevator Company

Leaflet Description

This leaflet provides spare parts information for type DAA24120E safety gear assembly. These safeties are manufactured by the Hangzhou Huning Elevator Accessories Co., Ltd.

该手册为安全钳 DAA24120E 的备件信息。该安全钳由杭州沪宁电梯配件有限公司制造。

Leaflet Revisions

Date Revised	Subject Matter Expert	Reason for Revision
Feb 06, 2018	Mengxi Liu	New SPL

Related Drawings

Drawing No.	Title	Drawing No.	Title
DAA24120E	Safety Gear	---	---
---	---	---	---

Related Documents

Document ID	Title
DAA24120E_FIM	Field Installation Manual
DAA24120E_BD	Basic Data

Subject Matter Expert

Name	Department
Mengxi Liu	CEC

About Spare Parts Leaflets...

This document is to make parts identification as easy as possible, the document cannot be all-inclusive. Elevator and escalator contracts classified as “special” or “custom” are not addressed here. For such contracts, please refer to specified information, the contract folder, TIPs, Field Education Articles, Construction Letters, etc. for further information.

If you have any suggestions about this document, please contact the subject matter expert listed on this page.

OS6000D Safety Gear

14-DAA24120E

It is forbidden to replace any single component of the safety assembly in the field except connecting nut.
除连接螺母外，工地上禁止替换安全钳装配中的任何单一的部件。

The whole safety assembly must be replaced as LRU, Please refer to field installation manual: DAA24120E_FIM.

Note: (1) Safety gear designed life is 30 years;

(2) GB/CE/JIS/KC: Safety gear suggest to be replaced if a freefall drop happens during operation;

(3) ASME: If slide lengths are not code compliant, refer to TIP 17.0-2 for correcting safety slide lengths. If slide lengths are still not code compliant, replace safeties.

需要时必须更换整个安全钳。请参考工地安装文件 DAA24120E_FIM.

注意：（1）安全钳的设计寿命是 30 年；

（2）GB/CE/JIS/KC:在电梯运行中发生自由落体，建议更换安全钳。

（3）ASME: 如果滑移长度不满足规范要求，参照 TIP 17.0-2 修正滑移长度。如果调整后还是不能满足规范要求，需要替换安全钳。

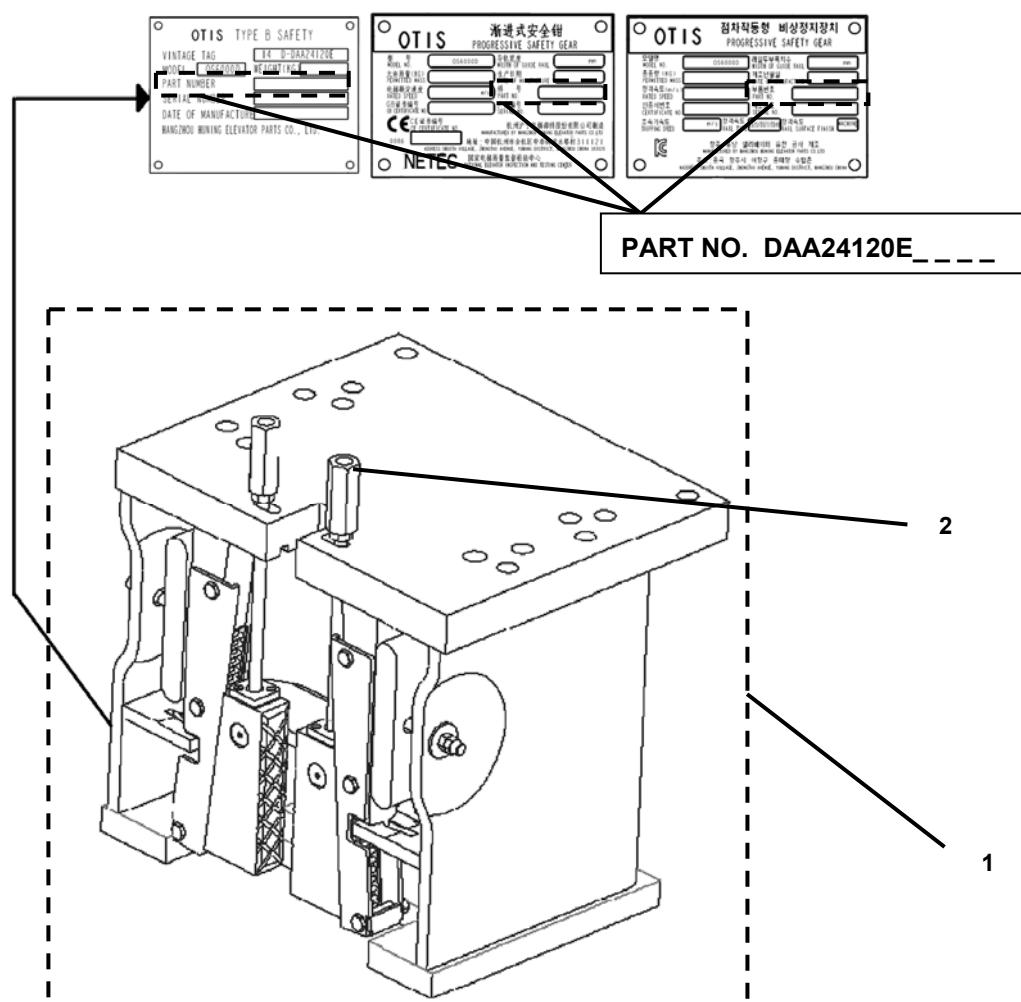

REF. No. 参考号	PART NO. 件号	DESCRIPTION 描述	REMARKS 备注
1	DAA24120E_-----	Assembly, Safety 安全钳	ASME A17.1, GB/CE/KC/JIS
2	DAA72BB1	Nut, Connecting, M12 M12 连接螺母	ASME A17.1, GB/CE/KC/JIS
	DAA72BB2	Nut, Connecting, M8 M8 连接螺母	GB/CE/KC/JIS

Note: Safety gear part number selection method:

- (1) For replacement safety assembly order: part number listed on old safety vintage tag.
- (2) For new safety assembly order: part number selection method / example see drawing DAA24120E.

注意: 安全钳件号选择方法:

- (1) 对于订购用于替换的安全钳, 安全钳件号参照旧安全钳的标签。
- (2) 对应首次订购新安全钳, 件号选取方法见图纸 DAA24120E。