

Top-of-Car Inspection Box

Spare Parts Leaflet

14-MAA24831A

August 15, 2014 / Page 1 of 3

**W/O
VINTAGE**

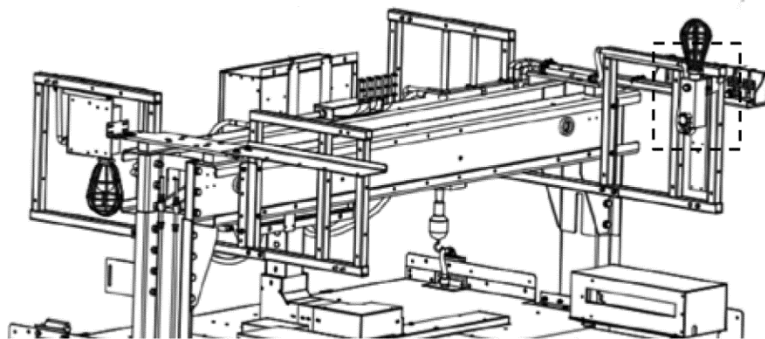
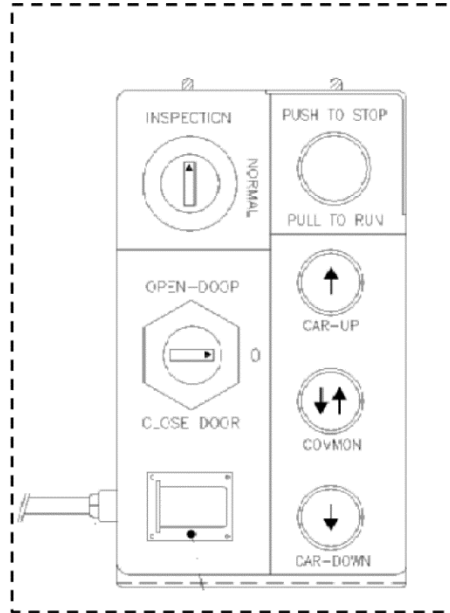

OTIS

SERVICE ENGINEERING
Otis Elevator Company
Bloomfield, Connecticut USA

Unpublished Work—© Otis Elevator Co.; 2014

Leaflet Description

This leaflet provides information for inspection box used in Skyrise NSAA product.

Leaflet Revisions

Date Revised	Subject Matter Expert	Reason for Revision
August 15, 2014	Allen Li	New SPL

Related Drawings

Drawing No.	Title	Drawing No.	Title
MBA24831A	Top-of-Car Inspection Box		

Related Documents

Document ID	Title

Subject Matter Expert

Name	Department
Sohaib Shaikh	OSC Electrical Engineering

About Spare Parts Leaflets...

This document lists the lowest replaceable units (LRUs) for the standard version of the product. The LRUs are chosen by a team of Otis associates representing engineering and manufacturing.

While goal of this document is to make parts identification as easy as possible, the document cannot be all-inclusive. Elevator and escalator contracts classified as “special” or “custom” are not addressed here. For such contracts, please refer to specified information, the contract folder, TIPS, Field Education Articles, Construction Letters, etc. for further information.

If you have any suggestions about this document, please contact the subject matter expert listed on this page.

Top-of-Car Inspection Box

14-MAA24831A

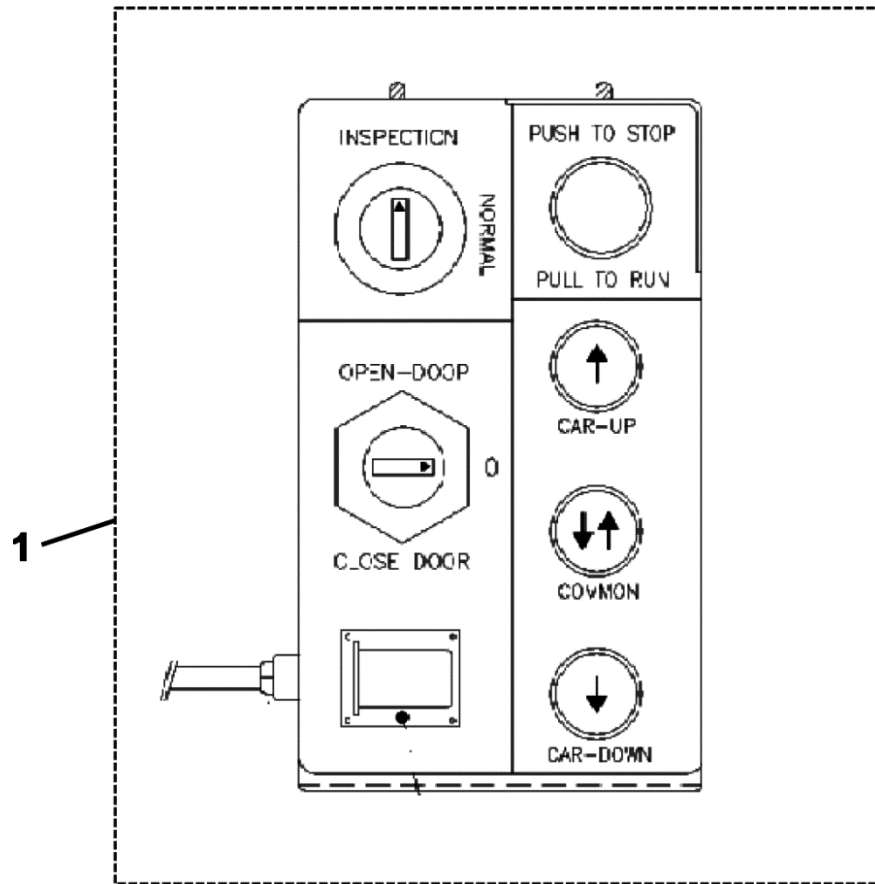

W/O VINTAGE		
REF. No.	PART No.	DESCRIPTION
1	MAA24831A001 MBA24831A001	Top-of-Car Inspection Box