

Governor Rope Tightener (Car)

Spare Parts Leaflet

15-A6481J

March 7, 2012 / Page 1 of 4

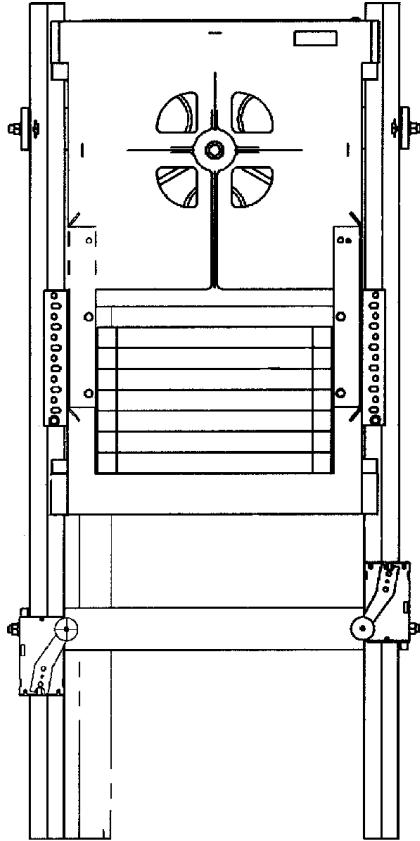

A6481J

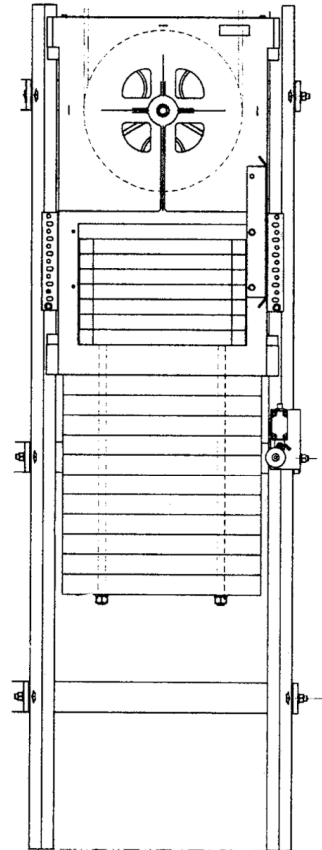

B6481J

C6481J

OTIS

Safety First!

SERVICE ENGINEERING
Otis Elevator Company
Bloomfield, Connecticut USA

Leaflet Description

This former pointer SPL lists LRUs for type A6481J governor rope tightener.

- A6481J was specified between 1997–2003
- B6481J was specified between 2003–2004
- C6481J was specified after 2004
- The B and C vintages implemented the new switch AAA22800T1.

Leaflet Revisions

Date Revised	Subject Matter Expert	Reason for Revision
July 1, 2002	Duane Stupienski	New Pointer SPL
March 15, 2002	Duane Stupienski	This former pointer SPL now lists LRUs for type A6481J governor rope tightener.
March 7, 2012	Gary Mendrala	Added arrangements B6481J and C6481J

Related Drawings

Drawing No.	Title	Drawing No.	Title
A6481J	Governor Rope Tightener	C6481J	Governor Rope Tightener
B6481J	Governor Rope Tightener		

Related Documents

Document ID	Title
15-6481AD	Type 6481AD Rope Tightener

Subject Matter Expert

Name	Department
Gary Mendrala	OSC Service Engineering

About Spare Parts Leaflets...

This document lists the lowest replaceable units (LRUs) for the standard version of the product. The LRUs are chosen by a team of Otis associates representing engineering and manufacturing.



While goal of this document is to make parts identification as easy as possible, the document cannot be all-inclusive. Elevator and escalator contracts classified as “special” or “custom” are not addressed here. For such contracts, please refer to specified information, the contract folder, TIPs, Field Education Articles, Construction Letters, etc. for further information.

If you have any suggestions about this document, please contact the subject matter expert listed on this page.

Slack Rope Switch (CEN) Arrangement A6481J Car Tension Frame

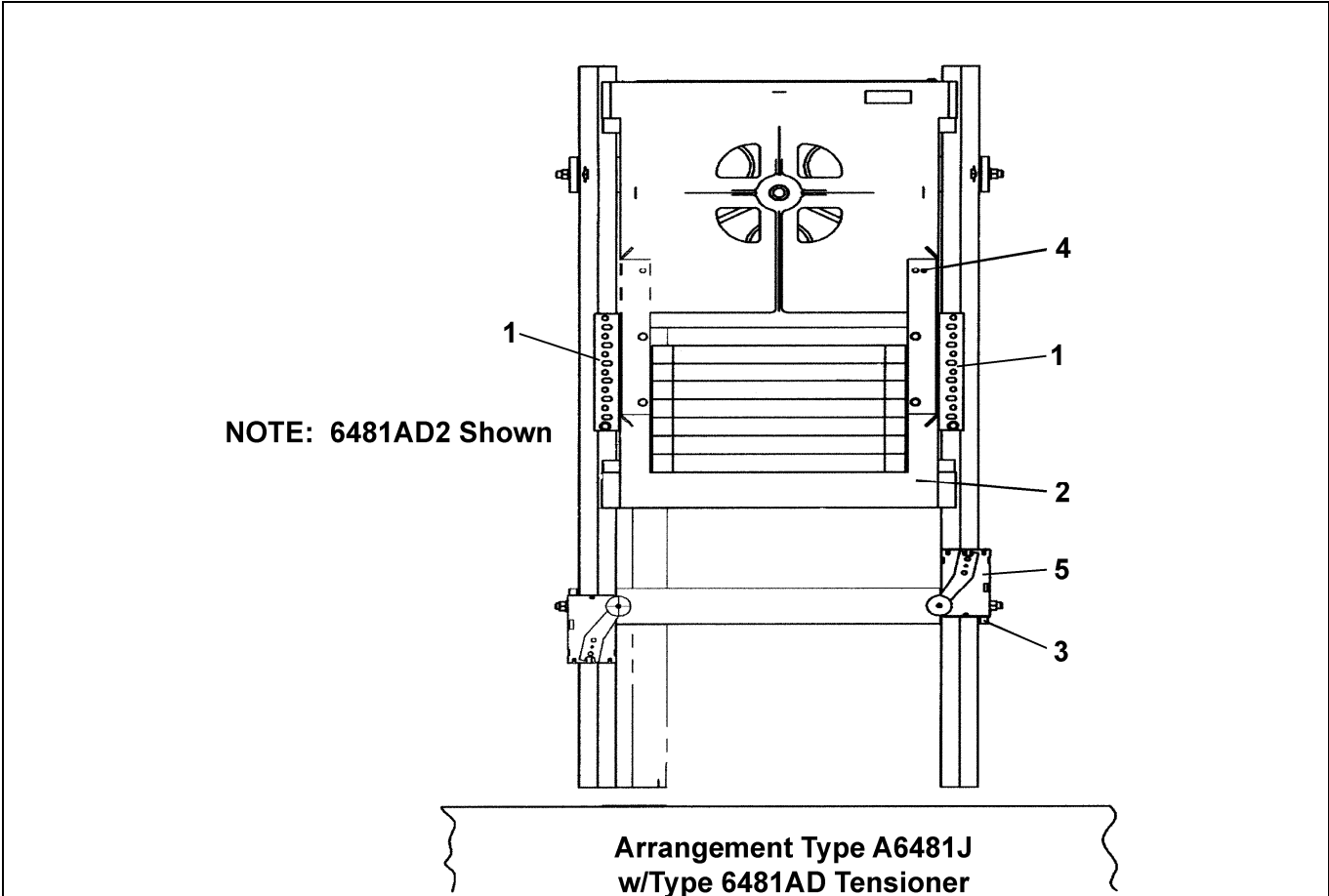
15-A6481J





A6481J		
REF. No.	PART No.	DESCRIPTION
1	283JV1	Angle
2	6481AD2	Assembly, Tension Frame (shown), Complete, w/o Weights, w/o Ratchet Frame,  SPL 15-6481AD
	6481AD3	Assembly, Tension Frame (not shown), Complete, w/o Weights, w/Heavy Load Bearings, Suited for Additional (10) Bottom Weights 955 lb. Application,  SPL 15-6481AD
3	AAA283APX1	Bracket (formed angle)
4	AAA327NY1	Cam
5	AAA6098NM3	Switch, Limit

Slack Rope Switch (CEN) Arrangements B6481J and C6481J Car Tension Frame

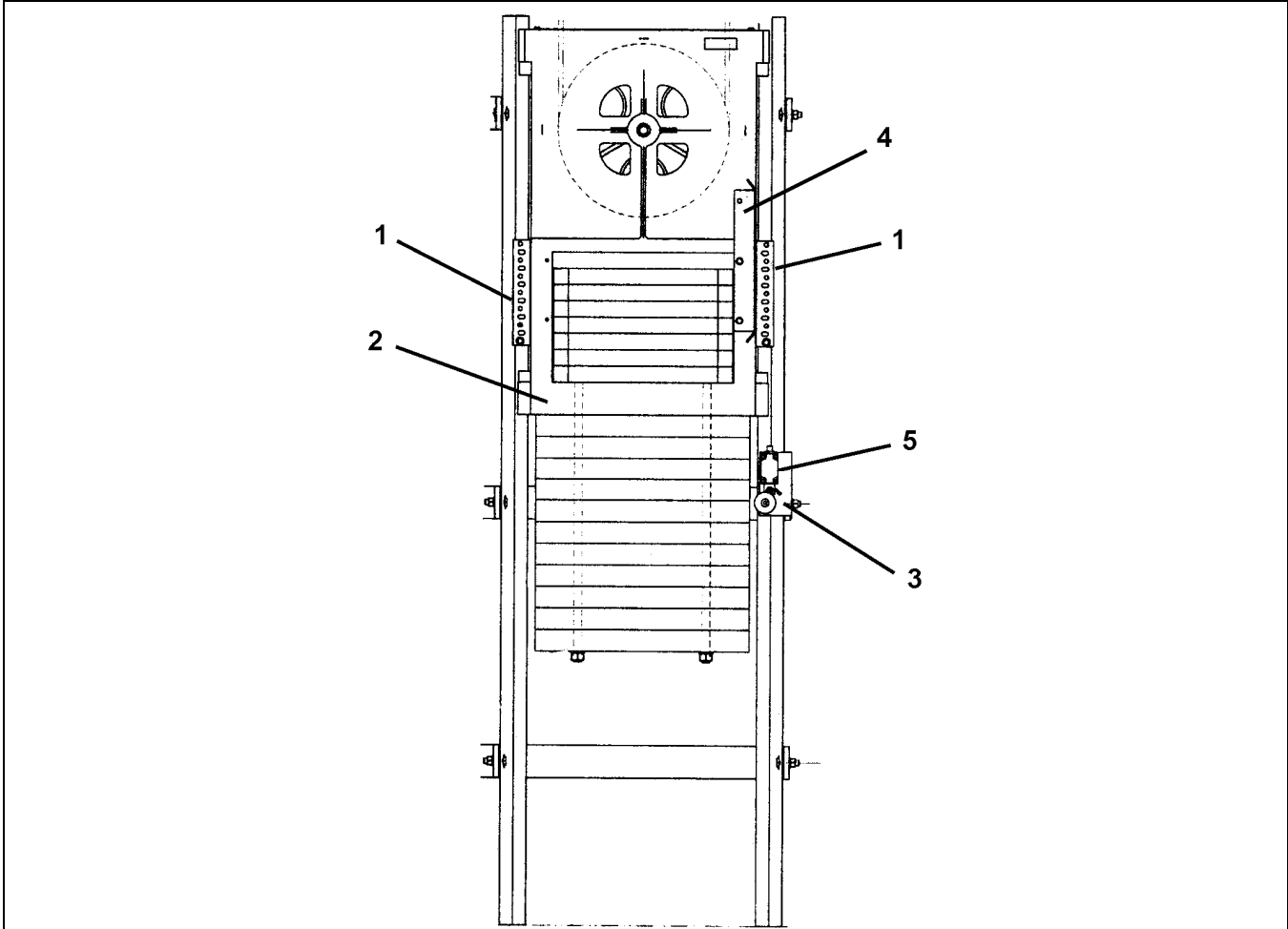
15-A6481J



**B6481J
C6481J**

REF. No.	PART No.	DESCRIPTION
1	283JV1	Angle
2	6481AD2	Assembly, Tension Frame (shown), Complete, w/o Weights, w/o Ratchet Frame,  SPL 15-6481AD
	6481AD3	Assembly, Tension Frame (not shown), Complete, w/o Weights, w/Heavy Load Bearings, Suited for Additional (10) Bottom Weights 955 lb. Application,  SPL 15-6481AD
3	AAA283APX2	Bracket (formed angle)
4	AAA327NY1	Cam
5	AAA22800T1	Switch, Limit