

Tandem Hydraulic Tie-
down Compensation
Device Skyrise®

Spare Parts Leaflet

16-AAA22640E

April 8, 2014/ Page 1 of 4

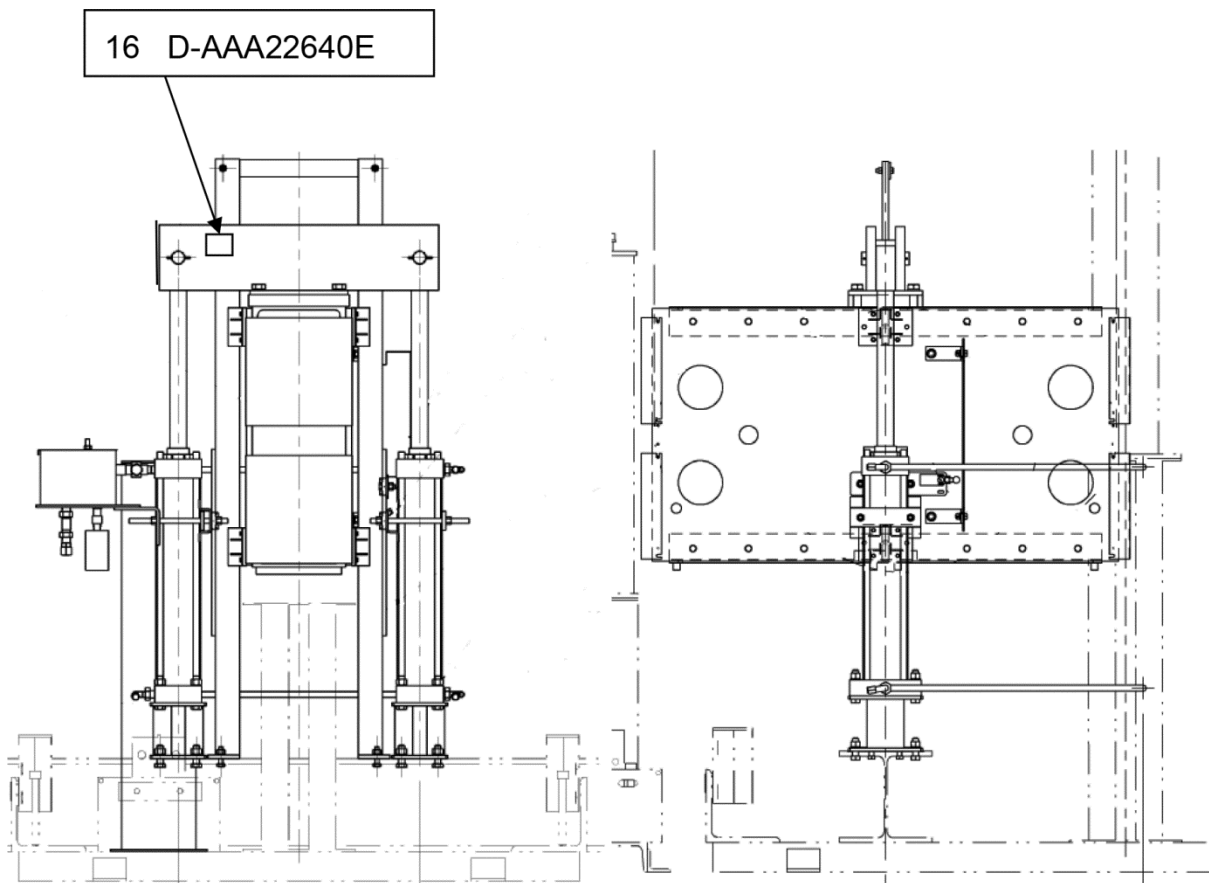

OTIS

SERVICE ENGINEERING

Otis Elevator Company

HR-SIT, Shanghai China

Unpublished Work—© Otis Elevator Co.; 2014

Leaflet Description

This SPL listed the lowest replaceable parts for A**22640E tandem hydraulic tie-down compensation device used on Skyrise.

Leaflet Revisions

Date Revised	Subject Matter Expert	Reason for Revision
April 8, 2014	Goto, Yasuhiro	New SPL

Related Drawings

Drawing No.	Title	Drawing No.	Title
ABA22640E	Comp. Sheave, Dual cylinder	JAA22641ABH	ASSEMBLY COMPENSATING SHEAVE FRAME

Related Documents

Document ID	Title
16-6042AV	Hydraulic Tie Down-Cylinder (pointer to SPL 16-6042AP)
16-6042AP	Free Compensation, Hydraulic Tie Down, Single and Dual Cylinder

Subject Matter Expert

Name	Department
Goto, Yasuhiro	SIT High Rise Shanghai

About Spare Parts Leaflets...

This document lists the lowest replaceable units (LRUs) for the standard version of the product. The LRUs are chosen by a team of Otis associates representing engineering and manufacturing.



While goal of this document is to make parts identification as easy as possible, the document cannot be all-inclusive. Elevator and escalator contracts classified as "special" or "custom" are not addressed here. For such contracts, please refer to specified information, the contract folder, TIPs, Field Education Articles, Construction Letters, etc. for further information.

If you have any suggestions about this document, please contact the subject matter expert listed on this page.

Tandem Hydraulic Tie-down Compensation Device

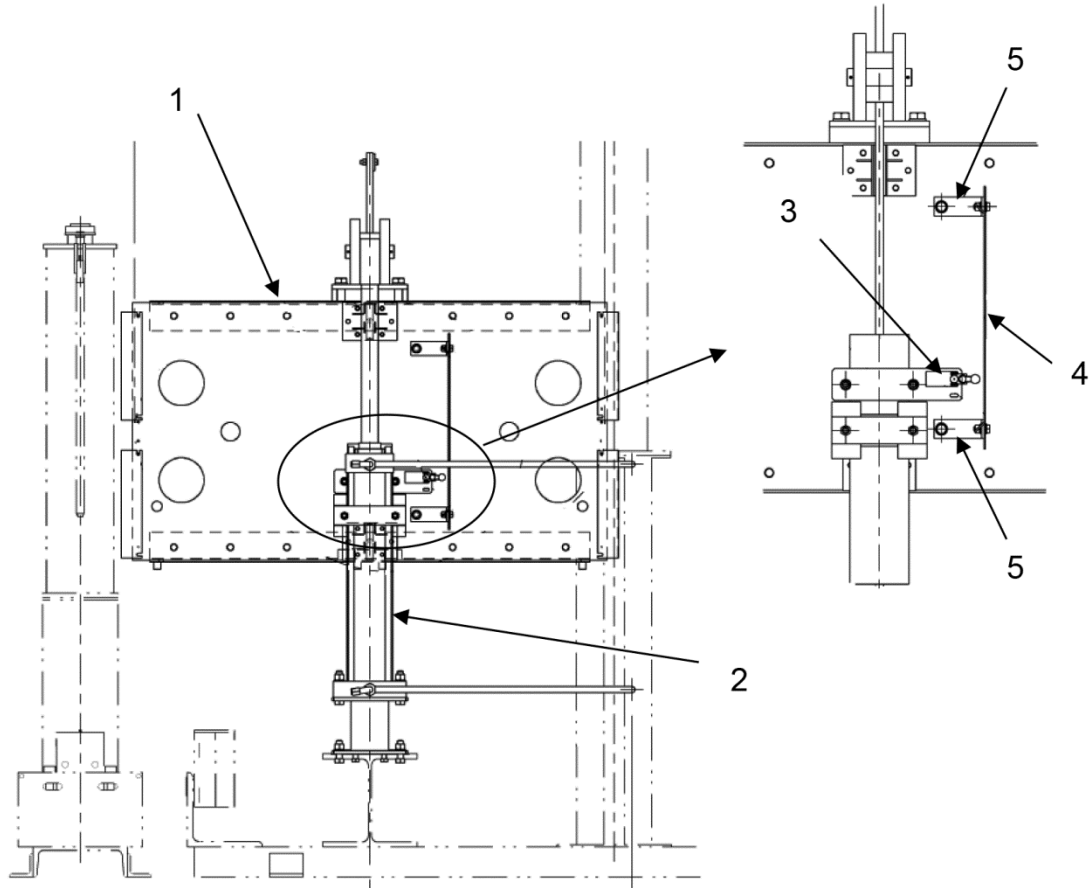
16-AAA22640E



REF. No.	PART No.	DESCRIPTION
	W/O AAA22640E ABA22640E	
1	---	Compensation Sheave  Page 4
2	---	Hydraulic Dual-Cylinder  SPL 16-6042AV, 16-6042AP
3	DAA26900G1 AAA26900J1	Limit Switch
4	AAA327QF1	Cam
5	AAA283BGY1	Angle, Cam support

Tandem Hydraulic Tie-down Compensation Device

16- AAA22640E

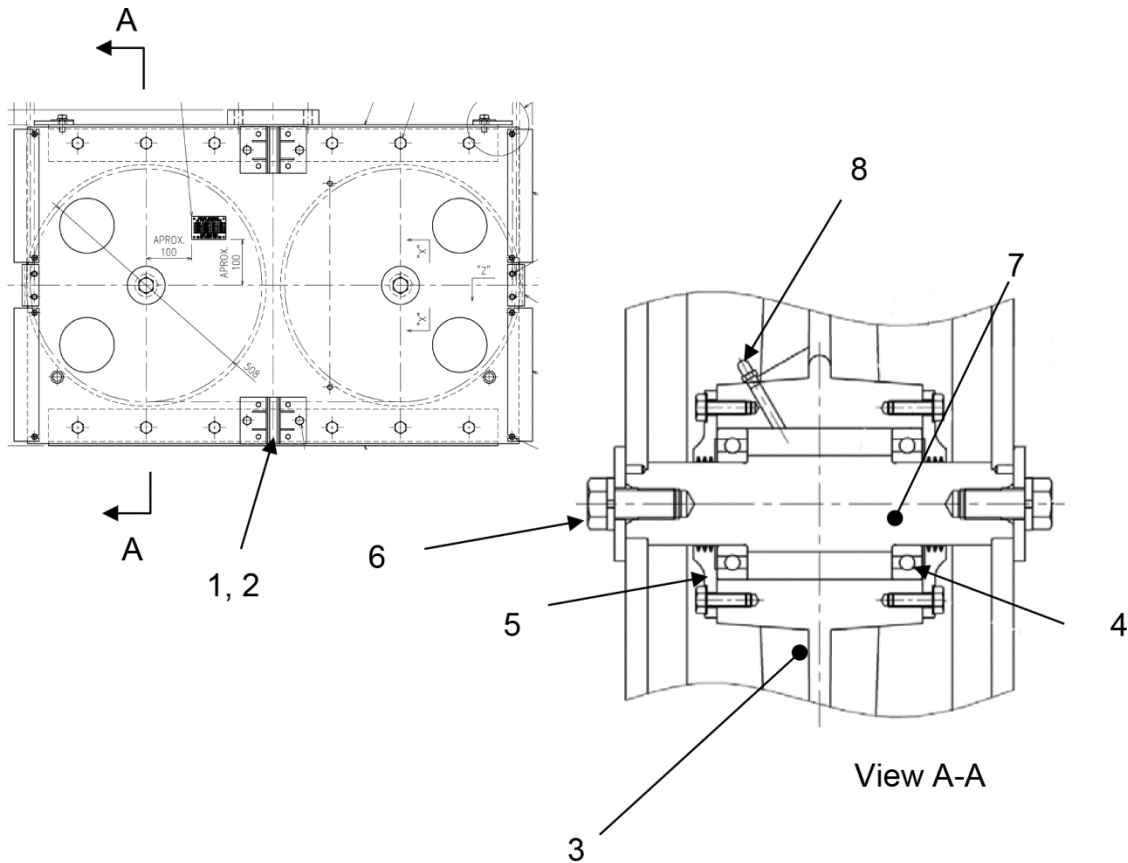

REF. No.	PART No.	DESCRIPTION
	W/O AAA22640E ABA22640E	
1	JAA24160ACW1	Guide Shoe (W/ GIB JAA380BN1)
2	JAA380ABN1	GIB
3	JAA265ADK1	Sheave, Dia. 508mm, 5x16mm Ropes
	JAA265ADK2	Sheave, Dia. 508mm, 6x16mm Ropes
	JAA265ADK3	Sheave, Dia. 508mm, 7x16mm Ropes
4	207AF4	Bearing
5	JAA346BYR1	Cover, Bearing
6	ISO4017M22x50-8.8Z	M22x50-8.8 Hex HD Screw
7	JAA495AEJ1	Shaft
8	435B6	Fitting
-	VP-420240	Grease (Otis Grease Spec #12) 14 ounce grease gun tube