

**G2M 2:1 Car &  
Counterweight Crosshead  
Gen2 Hitch Assembly  
(Modernization)**

**Spare Parts Leaflet**

**16-AAA392EE**

**August 31, 2022 / Page 1 of 5**

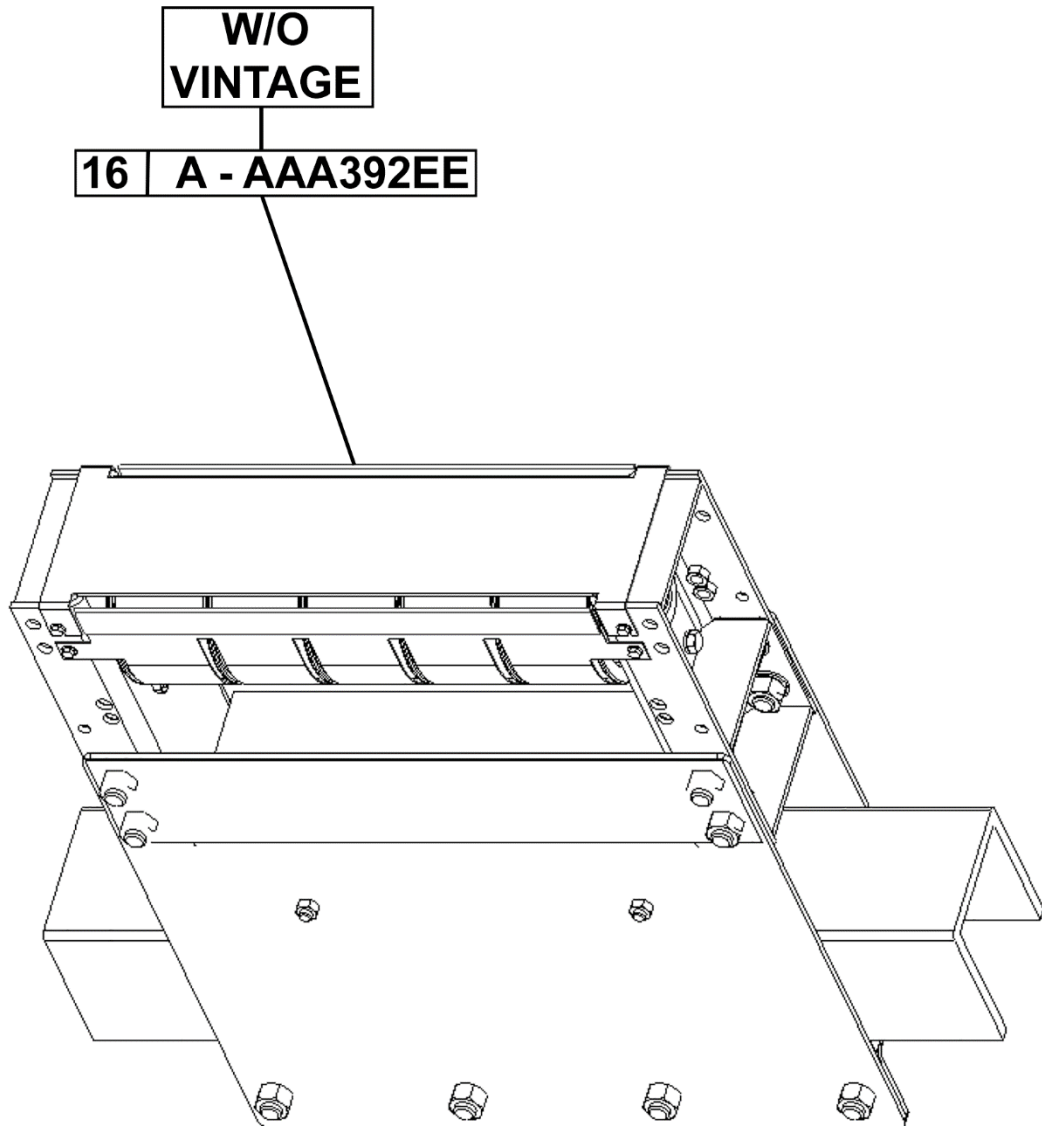

**OTIS**

This document does not contain any  
technical data subject to EAR or ITAR

**SERVICE ENGINEERING**  
**Otis Elevator Company**  
**Bloomfield, Connecticut USA**

Unpublished Work—© Otis Elevator Co.; 2022

**Leaflet Description**

The AAA392EE Gen2 hitch is used in the Gen2 Modernization system on both the car and cwt crossheads.

**NOTE:** The AAA392EE assembly has been shipped without a vintage tag.

**Leaflet Revisions**

<b>Date Revised</b>	<b>Subject Matter Expert</b>	<b>Reason for Revision</b>
August 31, 2022	Christian Kaljulaid	New SPL

**Related Drawings**

<b>Drawing No.</b>	<b>Title</b>	<b>Drawing No.</b>	<b>Title</b>
AAA392EE	Hitch, 2:1	AAA310RB	Block, Isolation
AAA20780D	Assembly CSB Sheave	AAA384AKR	Guard, 2:1 Gen2
AAA20780W	Sheave Assembly	AAA384AKQ	Guard, 2:1 Sheave
AAA20780AS	Sheave Assembly		

**Related Documents**

<b>Document ID</b>	<b>Title</b>
TIP 10.0-14	<i>Gen2 Sheave Replacement</i>
SPL 06-AAA20238AS	<i>Machine Room Stubby Gen2 Machine Bedplate</i>
SPL 06-AAA20238AP	<i>Machine Room Gen2 Machine Bedplate</i>

**Subject Matter Expert**

<b>Name</b>	<b>Department</b>
Christian Kaljulaid	MOD Mechanical Engineering

**About Spare Parts Leaflets...**

This document lists the lowest replaceable units (LRUs) for the standard version of the product. The LRUs are chosen by a team of Otis associates representing engineering and manufacturing.

While goal of this document is to make parts identification as easy as possible, the document cannot be all-inclusive. Elevator and escalator contracts classified as "special" or "custom" are not addressed here. For such contracts, please refer to specified information, the contract folder, TIPs, Field Education Articles, Construction Letters, etc. for further information.

If you have any suggestions about this document, please contact the subject matter expert listed on this page.

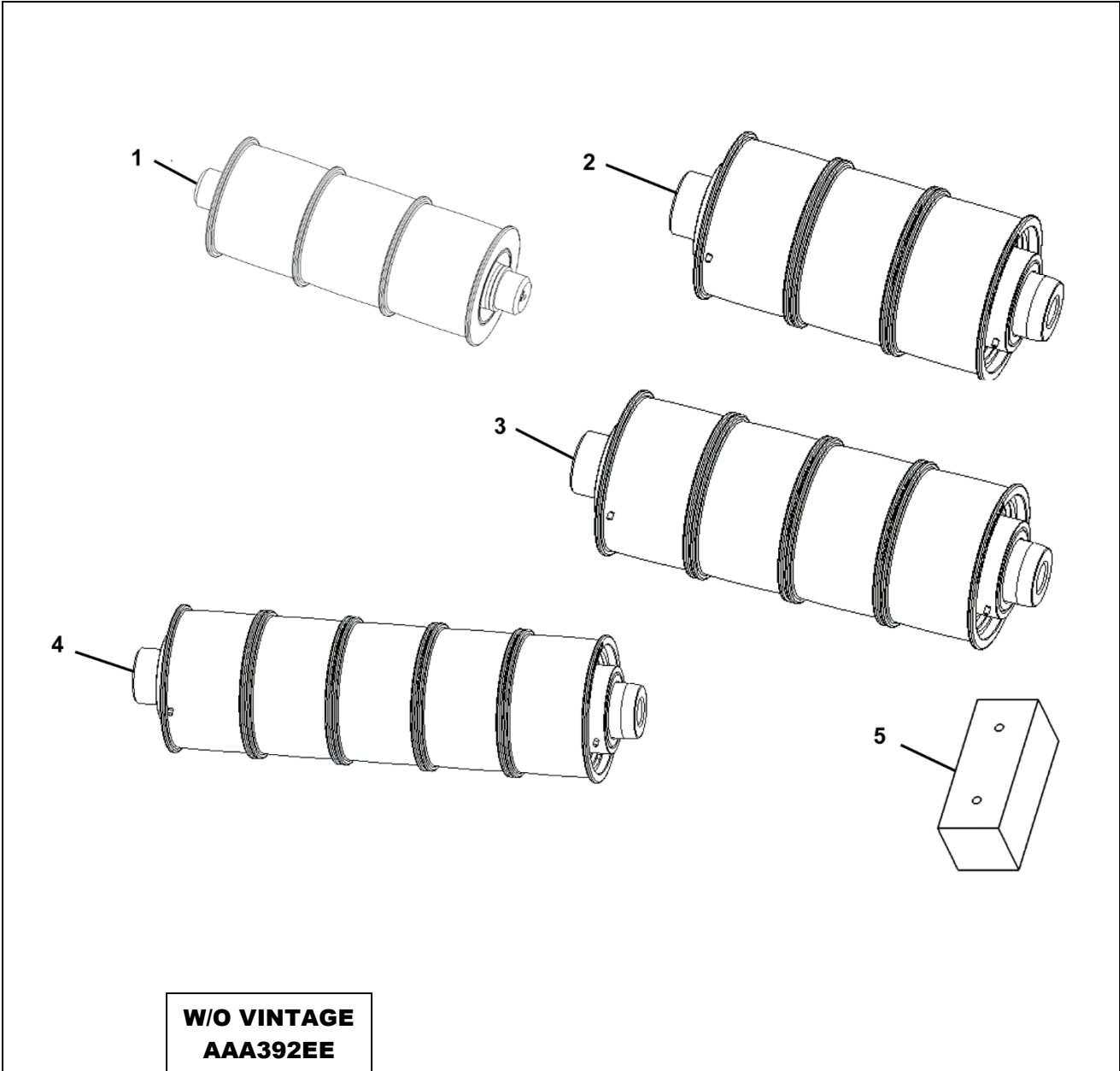

W/O VINTAGE AAA392EE			
REF. No.	PART No.	DESCRIPTION	REMARKS
1	AAA20780D2	Assembly, Sheave	3-Groove, Narrow Sheave, 115 mm Dia.
2	AAA20780W2 AAA20780AS3		3-Groove Sheave, 150 mm Dia.
3	AAA20780W3 AAA20780AS4		4-Groove Sheave, 150 mm Dia.
4	AAA20780W4 AAA20780AS1		5-Groove Sheave, 150 mm Dia.
5	AAA310RB2	Block, Sound Isolation	---

Sheave Diameter Reference "W"

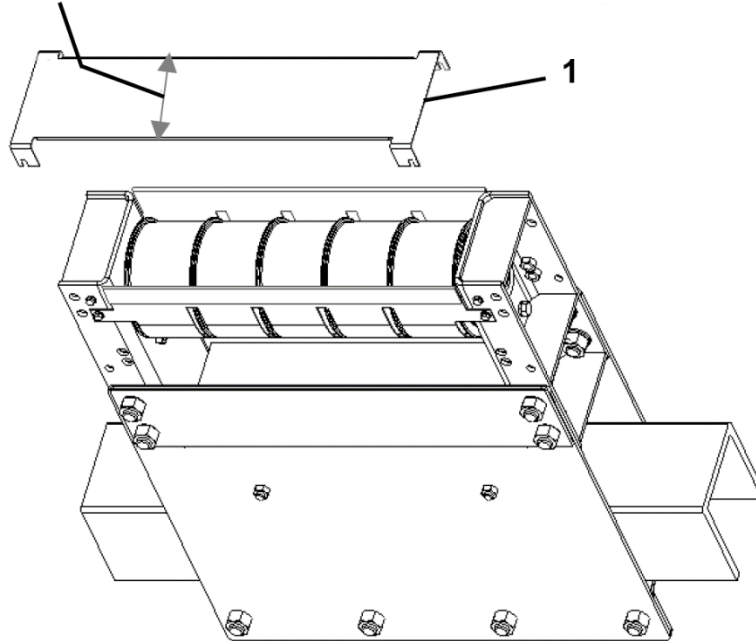

<b>W/O VINTAGE AAA392EE</b>			
<b>REF. No.</b>	<b>PART No.</b>	<b>DESCRIPTION</b>	<b>REMARKS</b>
1	AAA384AKR1	Guard, Top	5-Groove Sheave 150 mm Dia., 135 mm W
	AAA384AKR2		3-Groove, Narrow Sheave 115 mm Dia., 100 mm W
	AAA384AKR4		3-Groove Sheave 150 mm Dia., 135 mm W
	AAA384AKR5		4-Groove Sheave 150 mm Dia., 135 mm W

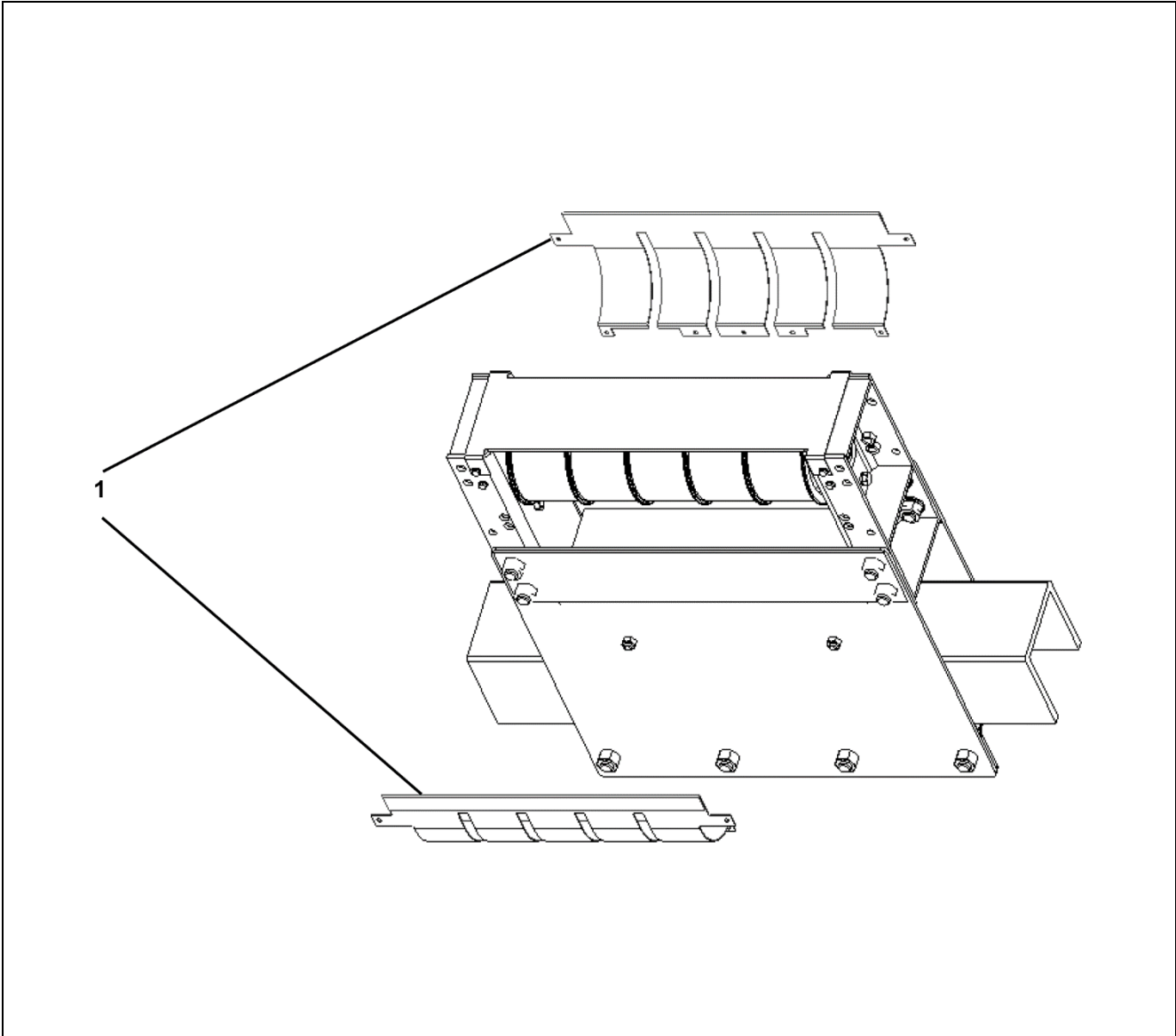

<b>W/O VINTAGE AAA392EE</b>			
<b>REF. No.</b>	<b>PART No.</b>	<b>DESCRIPTION</b>	<b>REMARKS</b>
1	AAA384AKQ1	Guard, Bottom	5-Groove Sheave 150 mm Dia.
	AAA384AKQ2		3-Groove, Narrow Sheave, 115 mm Dia.
	AAA384AKQ3		3-Groove Sheave 150 mm Dia.
	AAA384AKQ4		4-Groove Sheave 150 mm Dia.