

Ride Quality  
Door Equipment

Spare Parts Leaflet

19-AAA27050BU

May 1, 2001/ Page 1 of 5

W/O VINTAGE

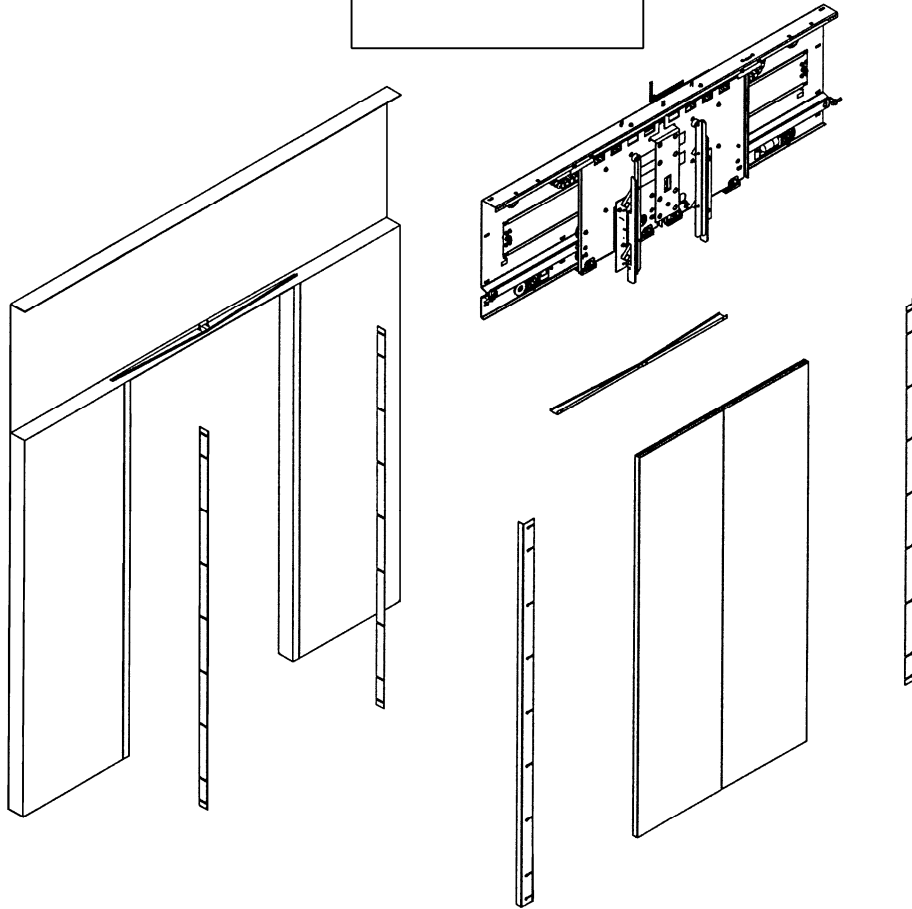

**OTIS**

Safety First!

SERVICE ENGINEERING

Otis Elevator Company  
Bloomfield, Connecticut USA

<b>History</b>
19-AAA27050BU
First Published: May 1, 2001

<b>Ride Quality Door Equipment</b>
--

REVISED DATE	RESPONSIBLE ENGINEER	PRIMARY REASON FOR REVISION
May 1, 2001	Duane Stupienski	New leaflet

### ***Leaflet Description***

This leaflet provides detailed information on the GHVS door seals initially released for HPLIM<sup>®</sup> door operator applications only.

RELATED LEAFLET NUMBERS	TITLES
---	---

<b>DRAWING REFERENCES</b>
AAA27050BU
AAA316GFV
AAA29000U

RELATED DOCUMENT NUMBERS	TITLES
---	---

This Spare Parts Leaflet (SPL) is prepared to assist you in determining the Lowest Replaceable Units (LRU) supported by the Otis Service Center for the standard version of the product titled on the preceding page. The parts are chosen by Otis associates from: Engineering, Field Engineering, Service Engineering, and Manufacturing. We attempt to make part identification as easy as possible. The SPL, however, cannot be all inclusive. Elevator and escalator contracts classified as either "special" or "custom" are not addressed. Alternative sources of information such as: the Contract Folder, Technical Information Publications, Field Education Articles, Construction Letters, etc. may give the information you are after. You live in the real world of maintaining your elevator and escalator contracts. On a daily basis, situations arise regarding parts identification and at times, for some reason, the part you need is not in the SPL. If you think a standard part not listed should be—let us know. We will respond.

--

**Duane Stupienski-OSC Service Engineering**

# Top Seal Doors

19-AAA2750BU

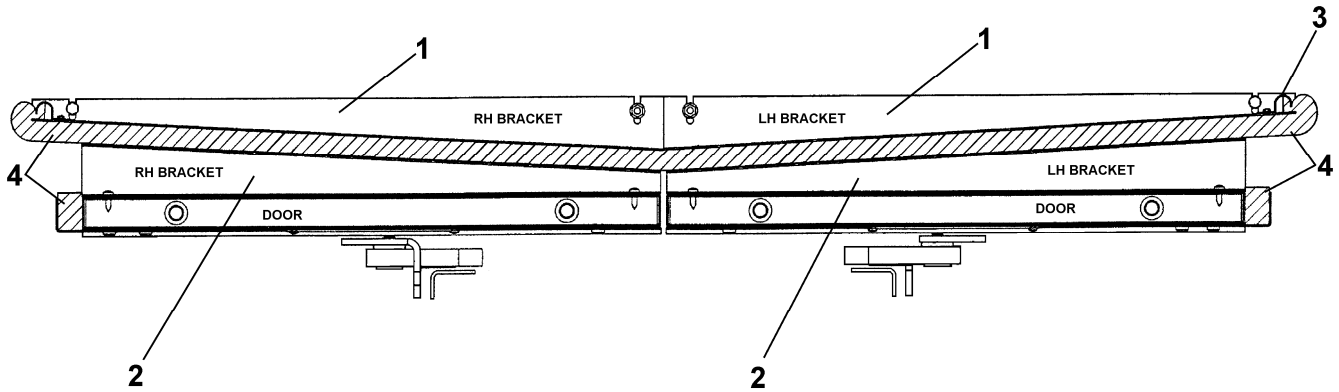

(Car Doors Top View)

REF. NO.	W/O VINTAGE PART or ML	DESCRIPTION	APPLICATION
1	AAA316GFV1	Bracket, GHVS Door Seals, Entrance Width = 42 in.	
	AAA316GFV2		
2	AAA316GFP1	Bracket, Cab Jamb Seal	
	AAA316GFP2		
3	AAA339MF4	Clips, Retaining, EPT Foam	
4	AAA429CM1	Foam, Door Seal, 78 in. x 35 in. Sheet, Thickness = 0.78 in.	

# Top Seal Doors

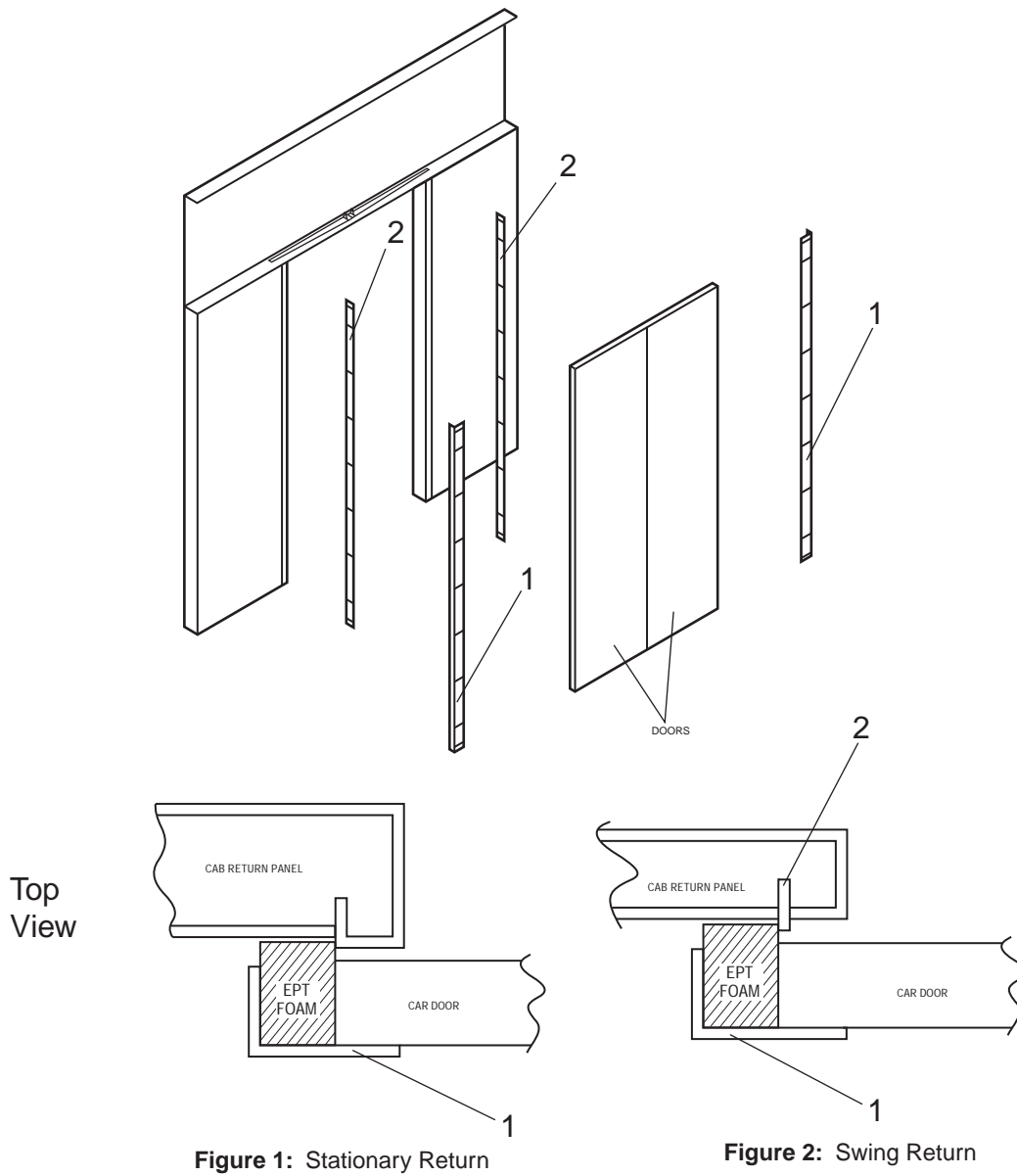

REF. NO.	W/O VINTAGE PART or ML	DESCRIPTION
1	AAA316GFS1	Bracket, Door Angle-Side Seal
2	AAA316GFR1	Bracket, Edge-Cab Side Seal (Only for swing return cab front applications ,  Figure 2)

# Top Seal Doors

19-AAA27050BU

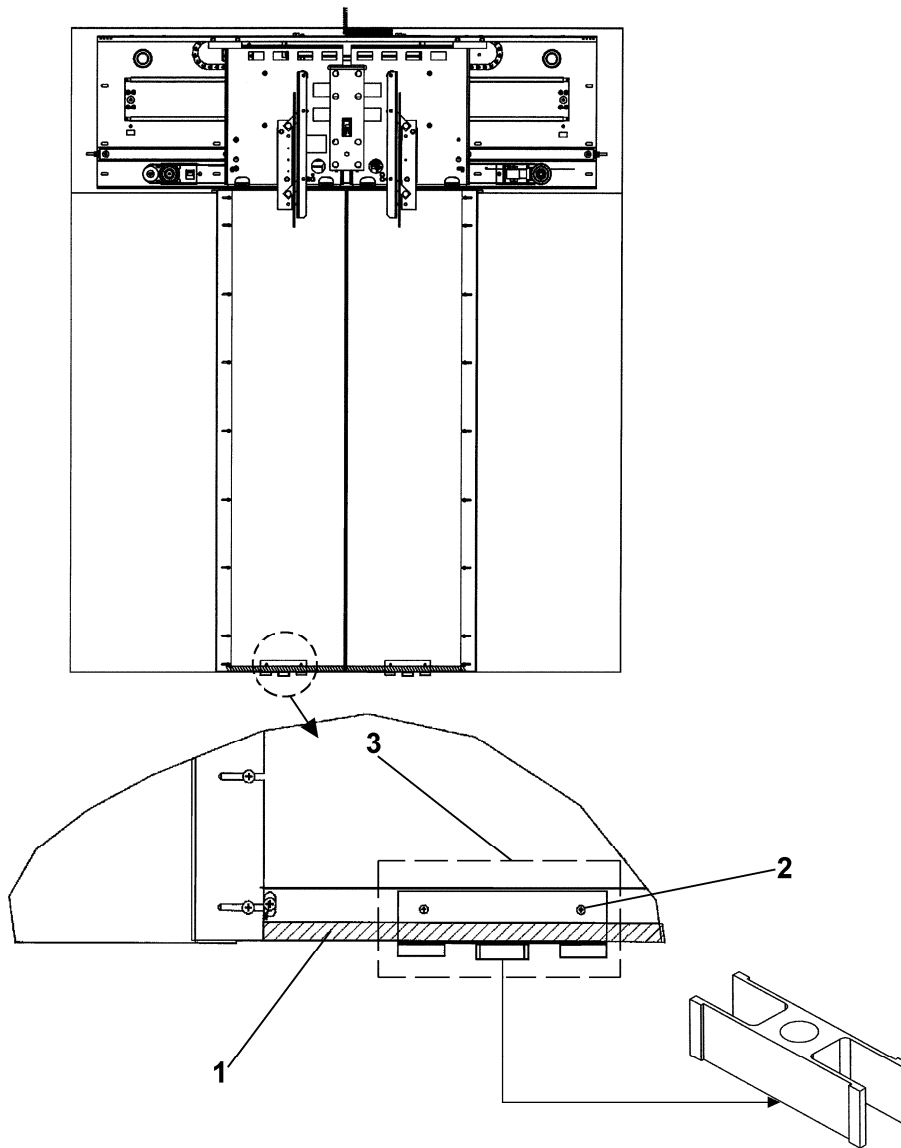

REF. NO.	W/O VINTAGE PART or ML	DESCRIPTION
1	AAA241L1	Brushes
2	AAA124FS3	Screw, Special, Supplied w/Guide Shoe
3	AAA27050CH1	Shoe, Door Guide