

Pit Door Contact Box

Spare Parts Leaflet

27-AAA22800S

March 5, 2014 / Page 1 of 4

W/O VINTAGE

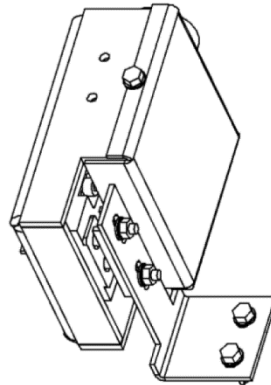

Sliding Door

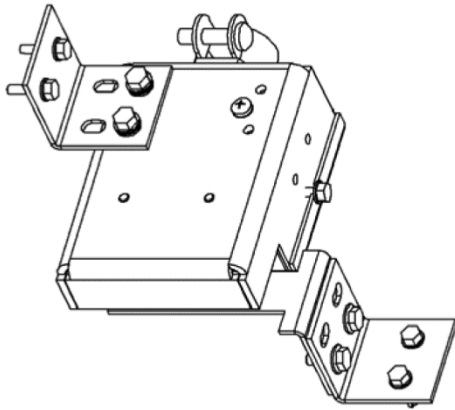

Door Opens Out

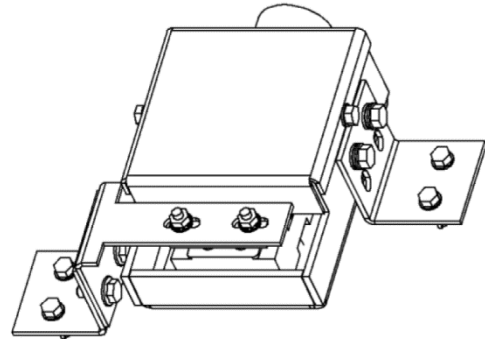

Door Opens In

OTIS

SERVICE ENGINEERING
Otis Elevator Company
Bloomfield, Connecticut USA

Unpublished Work—© Otis Elevator Co.; 2014

Leaflet Description

This spare parts leaflet covers replaceable components related to the assembly for pit door contact boxes.

Leaflet Revisions

Date Revised	Subject Matter Expert	Reason for Revision
March 5, 2014	Ali Bozorgzadeh	New SPL

Related Drawings

Drawing No.	Title	Drawing No.	Title
AAA22800S	Arrangement and Assembly, Pit Door Contact Box	---	---

Related Documents

Document ID	Title
---	---

Subject Matter Expert

Name	Department
Ali Bozorgzadeh	OSC Service Engineering

About Spare Parts Leaflets...

This document lists the lowest replaceable units (LRUs) for the standard version of the product. The LRUs are chosen by a team of Otis associates representing engineering and manufacturing.

While goal of this document is to make parts identification as easy as possible, the document cannot be all-inclusive. Elevator and escalator contracts classified as “special” or “custom” are not addressed here. For such contracts, please refer to specified information, the contract folder, TIPS, Field Education Articles, Construction Letters, etc. for further information.

If you have any suggestions about this document, please contact the subject matter expert listed on this page.

Pit Door Contact Box

27-AAA22800S

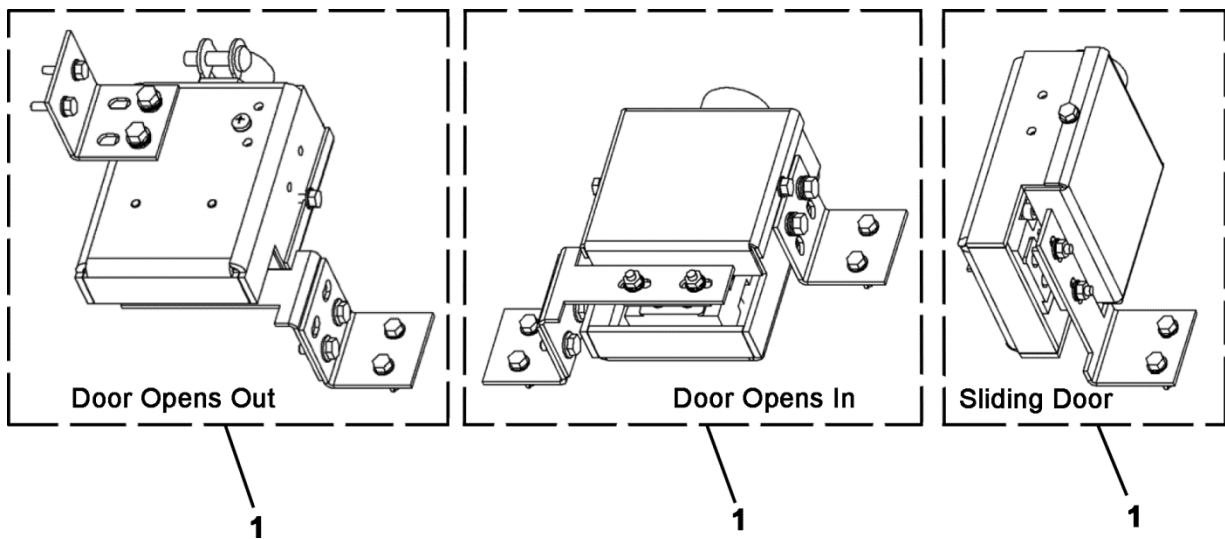

W/O VINTAGE		
REF. No.	PART No.	DESCRIPTION
1	AAA22800S400	Assembly, Pit Door Contact Box

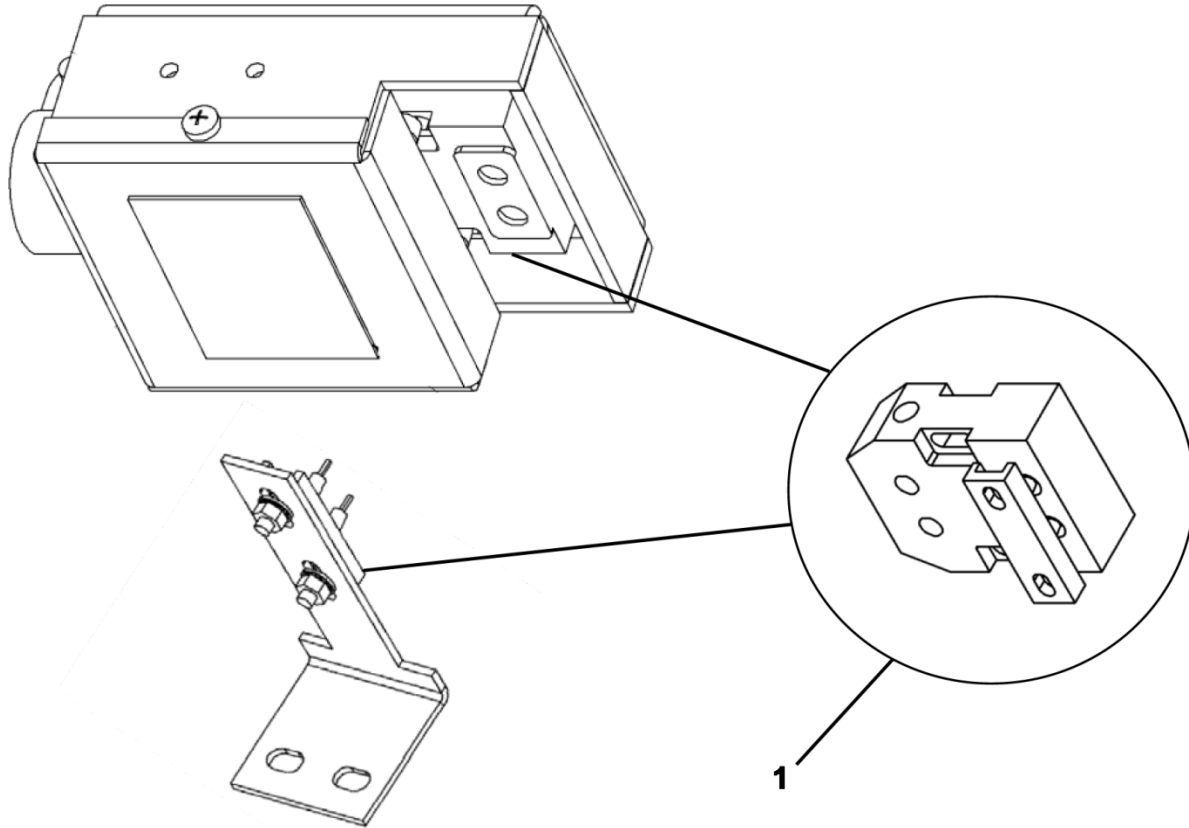

W/O VINTAGE		
REF. No.	PART No.	DESCRIPTION
1	AAA661B7	Contact and Bridge