

Keyswitch and Jewel Tablets

Spare Parts Leaflet
31-MAA250AC

February 8, 2017 / Page 1 of 13

**W/O
VINTAGE**

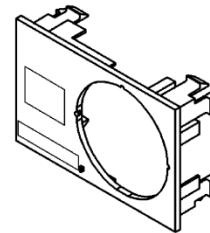
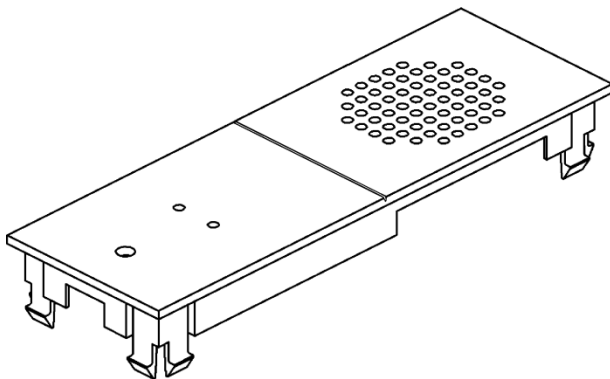
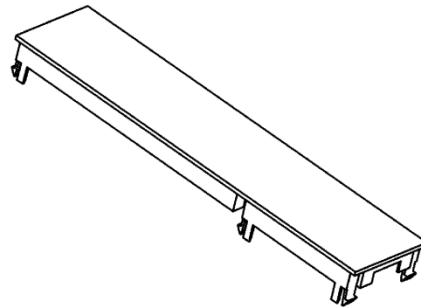
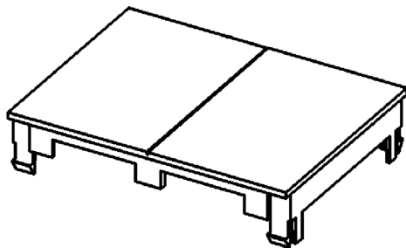

OTIS

This document does not contain any
technical data subject to EAR or ITAR

SERVICE ENGINEERING
Otis Elevator Company
Bloomfield, Connecticut USA

Unpublished Work—© Otis Elevator Co.; 2017

Leaflet Description

The SPL describes the lowest replaceable units for the fixture tablets used with Series 5 fixtures.

Leaflet Revisions

Date Revised	Subject Matter Expert	Reason for Revision
February 25, 2005	Troy Chicoine	New SPL
July 5, 2005	Joseph Zych	Add MAA250AC2-ACCESS to p. 3
June 10, 2009	Mike Bertini	Added Table of Contents. Add type MAA250AF tablets pp. 8–9.
February 8, 2017	Joseph Zych	Updated p. 13

Related Drawings

Drawing No.	Title	Drawing No.	Title
MAA250AC-AP	Tablet, Keyswitch and Jewel		

Related Documents

Document ID	Title
SPL 31-AAA25000DM	Car Operating Panel Series 5 with NEL Buttons

Subject Matter Expert

Name	Department
Joseph Zych	OSC Service Engineering

About Spare Parts Leaflets...

This document lists the lowest replaceable units (LRUs) for the standard version of the product. The LRUs are chosen by a team of Otis associates representing engineering and manufacturing.

While goal of this document is to make parts identification as easy as possible, the document cannot be all-inclusive. Elevator and escalator contracts classified as “special” or “custom” are not addressed here. For such contracts, please refer to specified information, the contract folder, TIPs, Field Education Articles, Construction Letters, etc. for further information.

If you have any suggestions about this document, please contact the subject matter expert listed on this page.

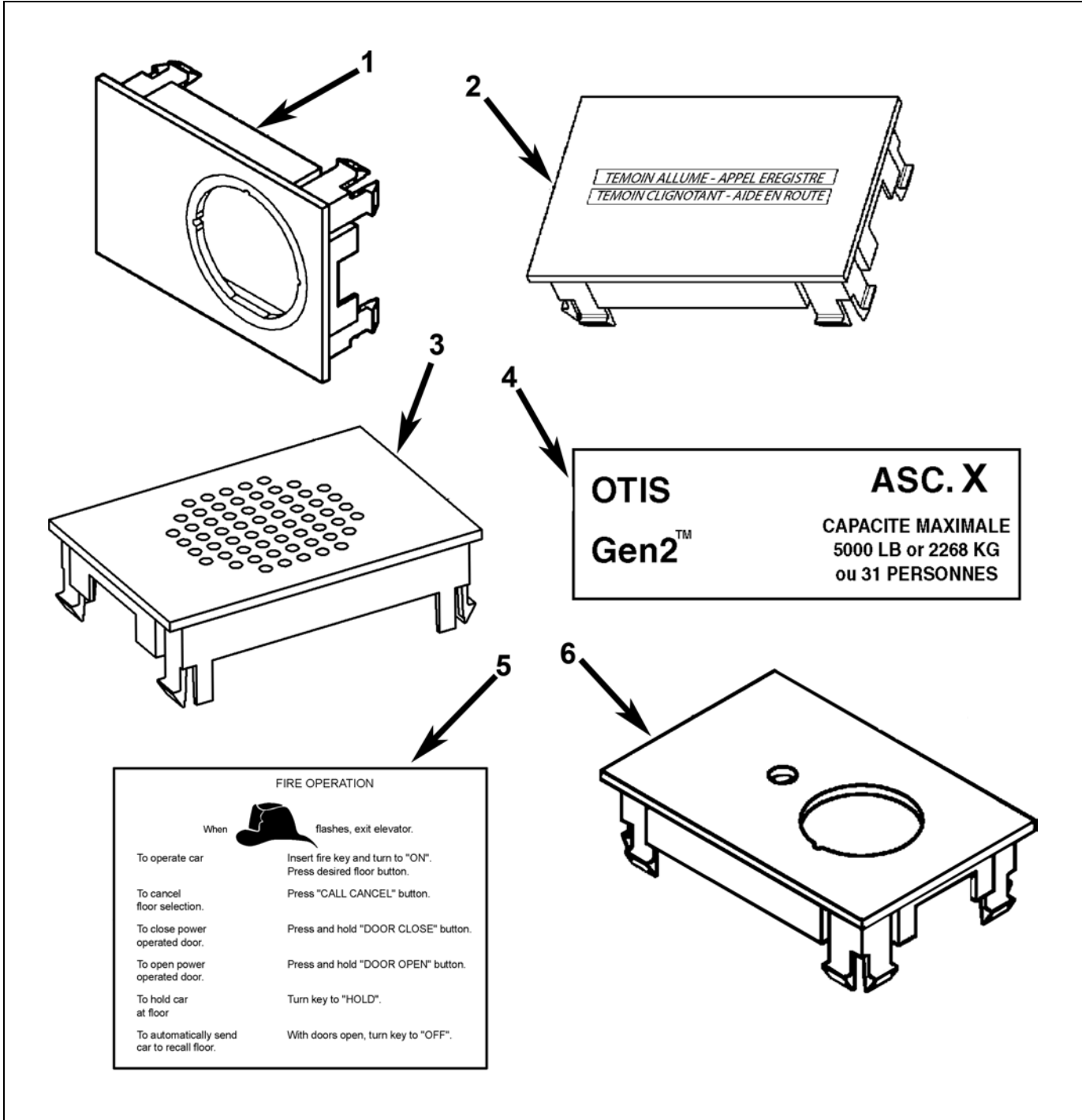

REF. No.	PAGE No.	DESCRIPTION
1	4-5	MAA250AC Type Tablets, Keyswitch and Jewel
2	6	MAA250AD Type Tablets, Blind and Help
3	7	MAA250AD, AJ Tablets, Speaker and PC Board Holder
4	8-9	MAA250AF Type Tablets, Car Number, Elevator Capacity
5	10-12	MAA250AL, Firefighters Instruction, No Smoking Tablets
6	13	MAA250AK, AP Type Tablets, NEL Buttons

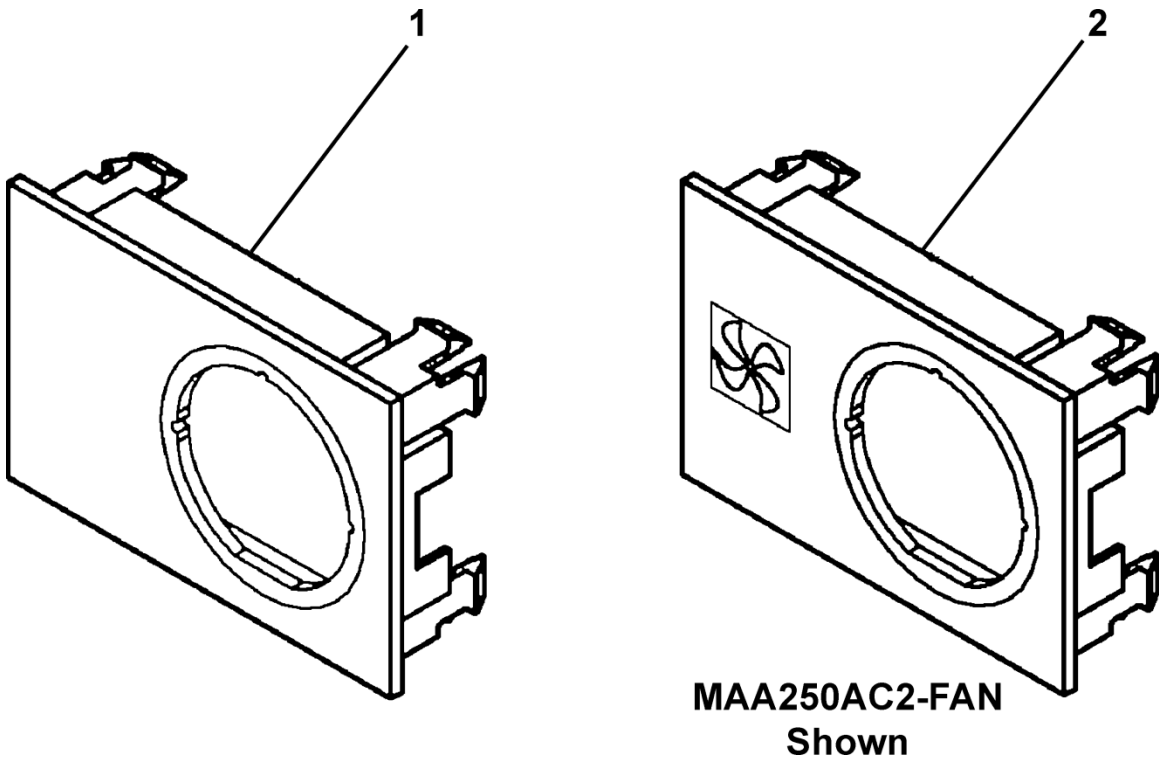

REF. No.	W/O VINTAGE PART No.	DESCRIPTION	LANGUAGE MARKING
1	MAA250AC1	Tablet, Blank	---
2	MAA250AC2-ACCESS	Access/Inspection	English
	MAA250AC2-EMERG-BI	Emergency Hospital Service	English and French
	MAA250AC2-EMERG-ENG	Emergency Hospital Service	English
	MAA250AC2-EMERG-FR	Emergency Hospital Service	French
	MAA250AC2-EMT-ENG	EMT Switch	English
	MAA250AC2-FAN	Fan (shown)	---
	MAA250AC2-LIGHT	Light	---
	MAA250AC2-FIRE	SES Phase II, ASME A17.1 Prior to 2000	---
	MAA250AC2-FIRE2K-BI	SES Phase II, ASME A17.1 2000 Code	English and French
	MAA250AC2-FIRE2K-ENG	SES, Phase II, ASME A17.1 2000 Code	English
	MAA250AC2-FIRE2K-FR	SES Phase II, ASME A17.1 2000 Code	French
MAA250AC2-FIRENYC	SES Phase II, NYC	---	

Continued on next page

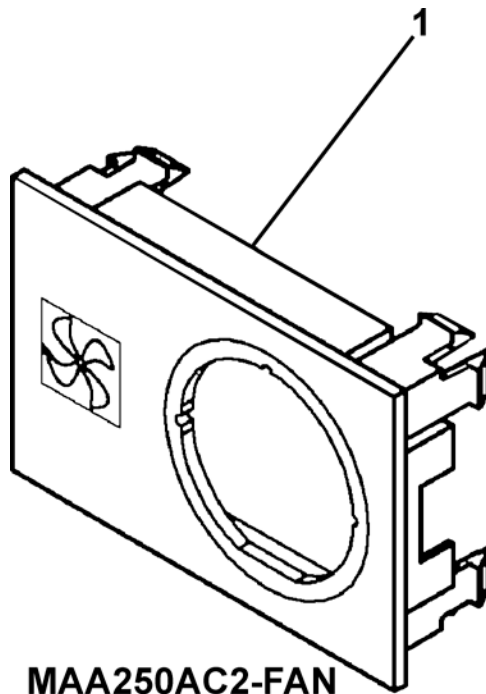

**MAA250AC2-FAN
Shown**

W/O VINTAGE			
REF. No.	PART No.	DESCRIPTION	LANGUAGE MARKING
1	MAA250AC2-INSPE-BI	Car Top Inspection	English and French
	MAA250AC2-INSPE-ENG	Car Top Inspection	English
	MAA250AC2-INSPE-FR	Car Top Inspection	French
	MAA250AC2-FLOCK-BI	Floor Lockout	English and French
	MAA250AC2-FLOCK-ENG	Floor Lockout	English
	MAA250AC2-FLOCK-FR	Floor Lockout	French
	MAA250AC2-INCARS-BI	In Car Stop Keyswitch	English and French
	MAA250AC2-INCARS-ENG	In Car Stop Keyswitch	English
	MAA250AC2-INDEP-BI	Independent Service	English and French
	MAA250AC2-INDEP-ENG	Independent Service	English
	MAA250AC2-INDEP-FR	Independent Service	French
	MAA250AC2-JRFLOOR-BI	Restricted Floor	English and French
	MAA250AC2-SECURE-BI	Secure Access	English and French
	MAA250AC2-SECURE-ENG	Secure access	English
	MAA250AC2-SECURE-FR	Secure Access	French

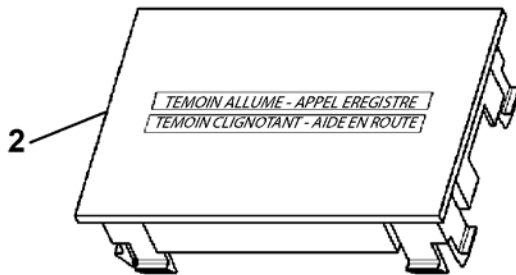
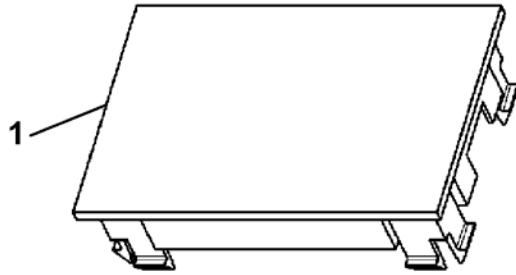

TEMOIN ALLUME - APPEL EREGISTRE
TEMOIN CLIGNOTANT - AIDE EN ROUTE

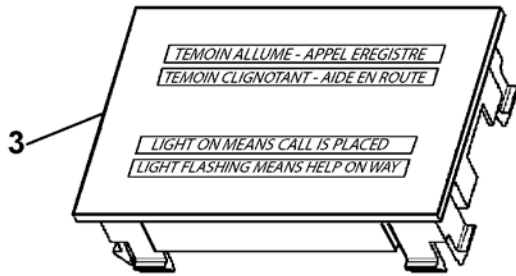

TEMOIN ALLUME - APPEL EREGISTRE
TEMOIN CLIGNOTANT - AIDE EN ROUTE
LIGHT ON MEANS CALL IS PLACED
LIGHT FLASHING MEANS HELP ON WAY

W/O VINTAGE		
REF. No.	PART No.	DESCRIPTION
1	MAA250AD1	Blind Single
2	MAA250AD2	Instructions Help/ADA Phone Button, French
3	MAA250AD3	Instructions Help/ADA Phone Button, French and English

MAA250AE PC Board Tablet

MAA250AE Speaker, Microphone

31-MAA250AC

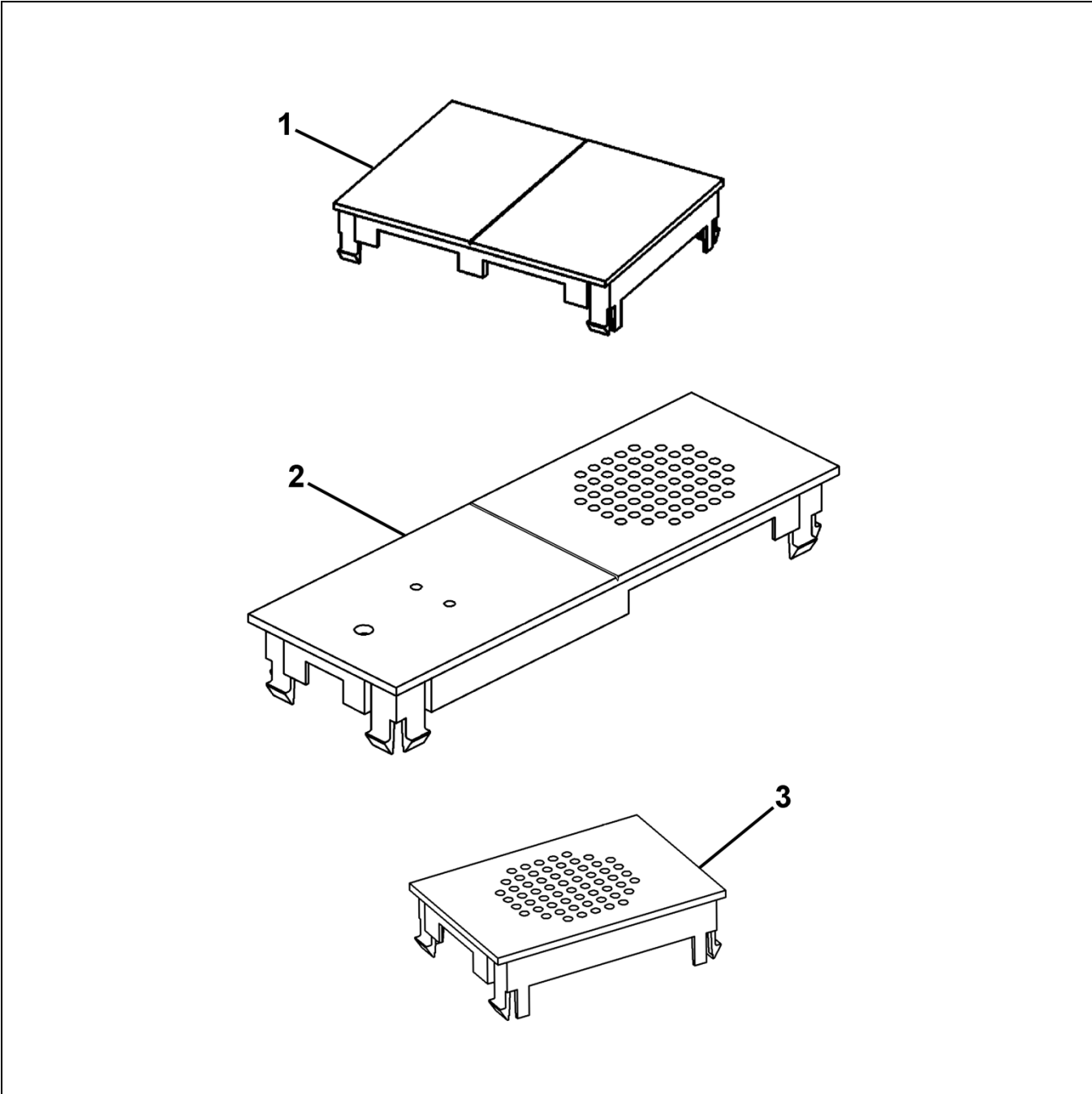

REF. No.	W/O VINTAGE PART No.	DESCRIPTION
1	MAA250AE1	Tablet, PCB Holder
2	MAA250AJ1	Tablet, Speaker and Microphone
3	MAA250AJ2	Tablet, Speaker

All capacity tablets are specified order items using this and next page.

Specify your wanted tablet by answering the questions and writing them into Table C, *Tablets Part Numbers*, along the row corresponding to your responses.

- 1) Determine reference number of the wanted tablet style and language from the below pictures
- 2) Determine tablet length, Table B. **NOTE:** Some tablets offered in two lengths. Some are only one length. Use responses of Steps 1 and Table B as row to write in the full part number.
- 3) From Table A, select reference number of desired capacity and write it in under column: Duty.
- 4) Optional: Indicate one or two alphanumeric characters (A–Z, 0–9) of car number (for traction systems) or elevator number (for hydro systems) for position X on tablet.

NOTE: If picture references 2, 3, 5 or 6 (p/n MAA250AF5, 6, 9, or 10) are selected without a car or elevator number, the capacity statement will be centered on the tablet horizontally and vertically.

The completed line is the part number of your defined tablet. Be sure to include dashes (-).

Examples: Want a 247.5 mm (9.75 in.) long tablet with layout and language pictured as reference number four. Capacity statement will be for a 3000 lb. duty and a car number of 12. The full part number will be: MAA250AF8-19-12.

Want a tablet represented by picture reference two with a 2500 lb. duty statement but without a car or elevator number engraving. The full part number will be: MAA250AF5-3. Note that because there is no car/elevator engraving, capacity statement will be centered on tablet.

NOTE: Markings are white text on black tablet.

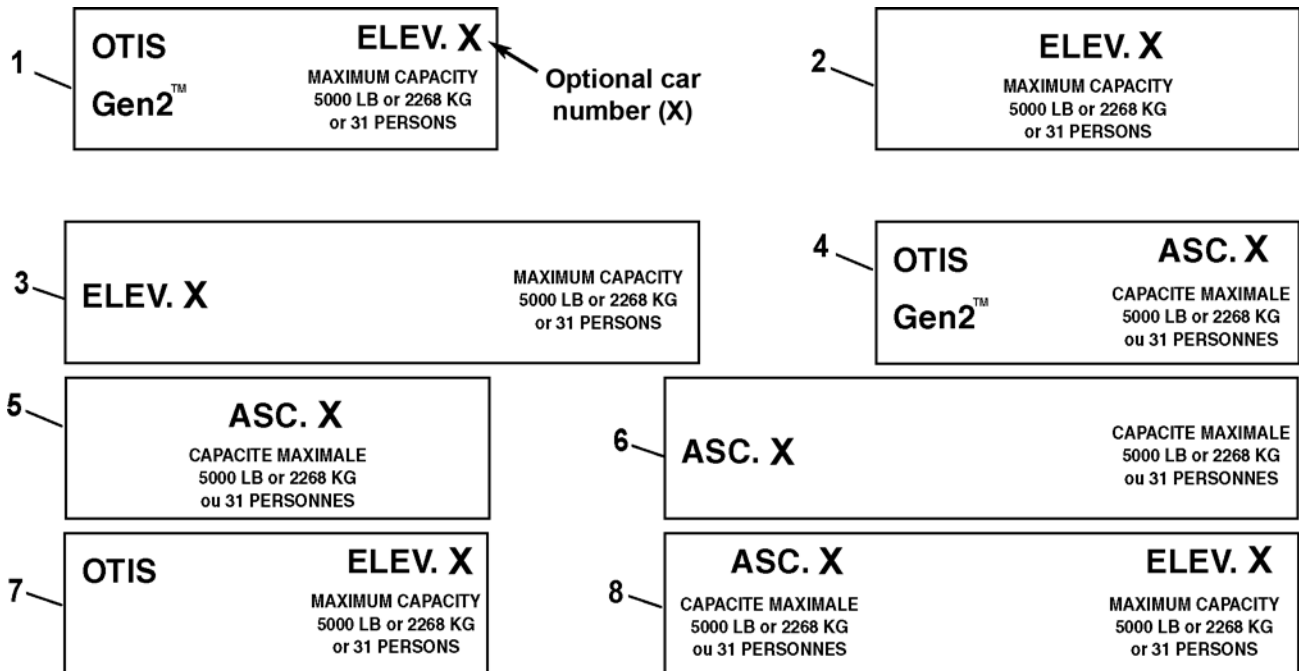

Continued on next page.

Table A: Capacity Statements for Weight and Persons

DUTY LOAD	REF. No.	ENGLISH	REF. No.	FRENCH
2000	1	2000 LB or 907 KG or 12 Persons	16	2000 LB ou 907 KG ou 12 Personnes
2100	2	2100 LB or 953 KG or 12 Persons	17	2100 LB ou 953 KG ou 12 Personnes
2500	3	2500 LB or 1134 KG or 15 Persons	18	2500 LB ou 1134 KG ou 15 Personnes
3000	4	3000 LB or 1361 KG or 18 Persons	19	3000 LB ou 1361 KG ou 18 Personnes
3500	5	3500 LB or 1588 KG or 21 Persons	20	3500 LB ou 1588 KG ou 21 Personnes
4000	6	4000 LB or 1814 KG or 25 Persons	21	4000 LB ou 1814 KG ou 25 Personnes
4500	7	4500 LB or 2041 KG or 28 Persons	22	4500 LB ou 2041 KG ou 28 Personnes
5000	8	5000 LB or 2268 KG or 31 Persons	23	5000 LB ou 2268 KG ou 31 Personnes
5500	9	5500 LB or 2494 KG or 34 Persons	24	5500 LB ou 2494 KG ou 34 Personnes
6000	10	6000 LB or 2721 KG or 37 Persons	25	6000 LB ou 2721 KG ou 37 Personnes
6500	11	6500 LB or 2948 KG or 40 Persons	26	6500 LB ou 2948 KG ou 40 Personnes
7000	12	7000 LB or 3175 KG or 43 Persons	27	7000 LB ou 3175 KG ou 43 Personnes
7500	13	7500 LB or 3402 KG or 46 Persons	28	7500 LB ou 3402 KG ou 46 Personnes
8000	14	8000 LB or 3628 KG or 50 Persons	29	8000 LB ou 3628 KG ou 50 Personnes
8500	15	8500 LB or 3855 KG or 53 Persons	30	8500 LB ou 3855 KG ou 53 Personnes

Table B: Tablet Length

Tablet Length (mm)
1 = 165.0 2 = 247.5
1
2
1
2
1
2
1
2
1
2
1
2

Table C: Tablets Part Numbers

Step 1	---	Step 3	Step 4
Picture Ref. No.	PART NO.	Duty	Car/Elevator Number
1	MAA250AF3	-	-
1	MAA250AF4	-	-
2	MAA250AF5	-	-
3	MAA250AF6	-	-
4	MAA250AF7	-	-
4	MAA250AF8	-	-
5	MAA250AF9	-	-
6	MAA250AF10	-	-
7	MAA250AF11	-	-
7	MAA250AF12	-	-
8	MAA250AF13	-	-
8	MAA250AF14	-	-
---	MAA250AF1	Tablet, Blank, 165.0 mm L	
---	MAA250AF2	Tablet, Blank, 247.5 mm L	

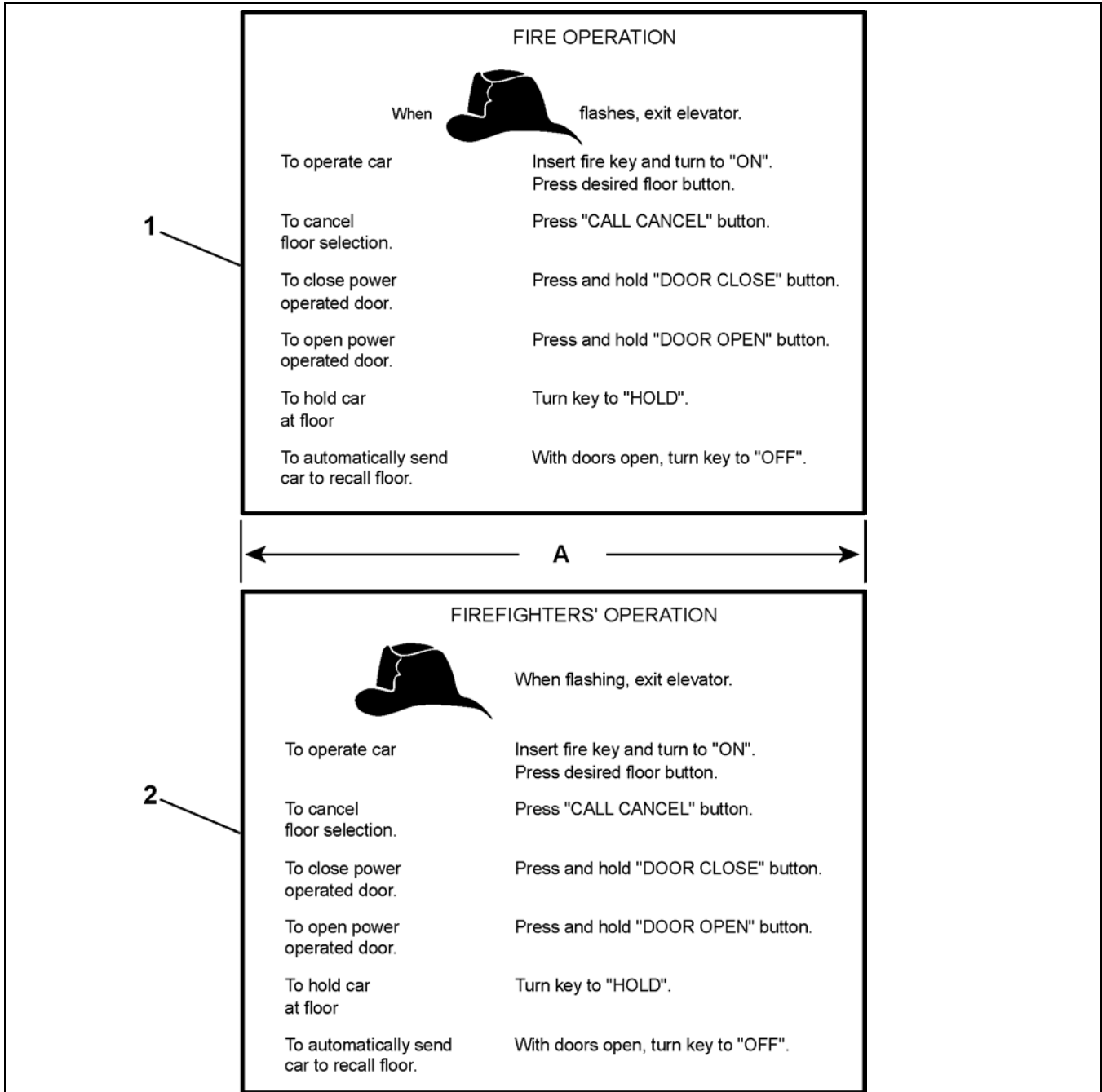

W/O VINTAGE		
REF. No.	PART No.	DESCRIPTION
1	MAA250AL3	Tablet, with Phase II Emergency In-Car Operation Instructions, English, A17.1-2000/B44-00, A = 165 mm
	MAA250AL4	Tablet, with Phase II Emergency In-Car Operation Instructions, English, A17.1-2000/B44-00, A = 247.5 mm
2	MAA250AL5	Tablet, with Phase II Emergency In-Car Operation Instructions, English, A17.1-1998, A = 165 mm
	MAA250AL6	Tablet, with Phase II Emergency In-Car Operation Instructions, English, A17.1-1998, A = 247.5 mm

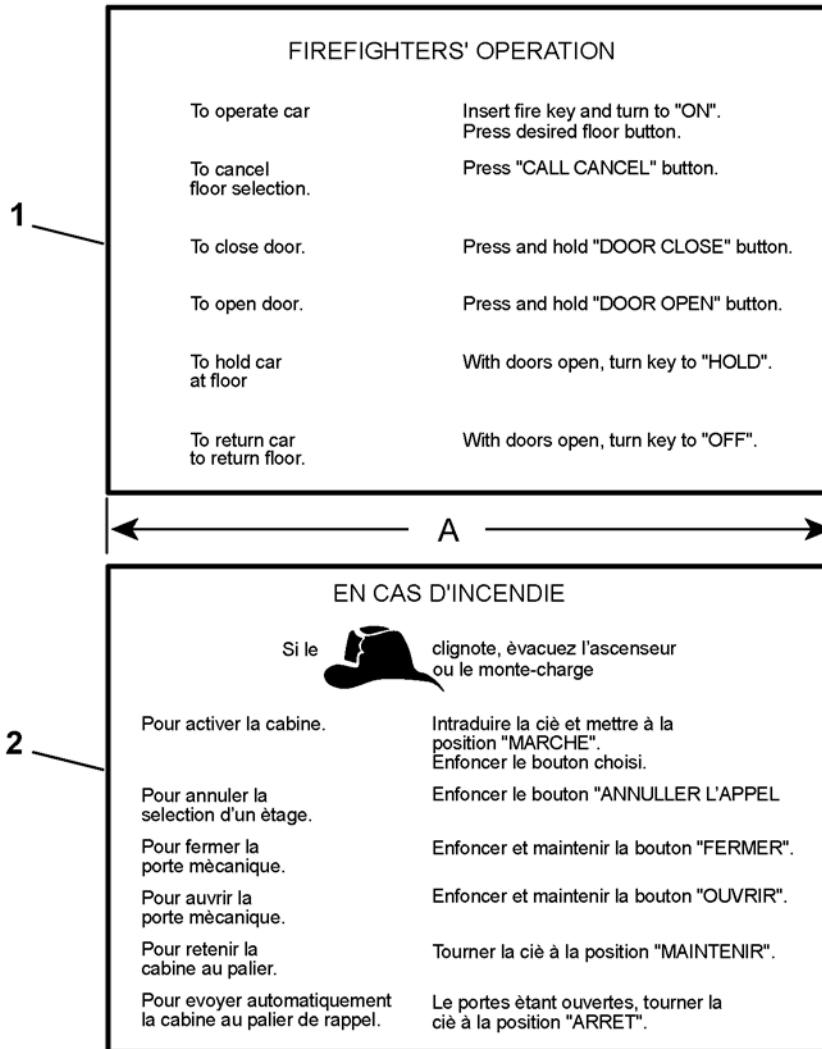
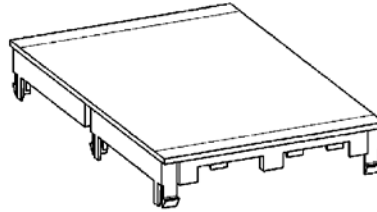

REF. No.	W/O VINTAGE PART No.	DESCRIPTION
1	MAA250AL7	Tablet, with Phase II Emergency In-Car Operation Instructions, English, A17.1-1986, A = 165 mm
	MAA250AL8	Tablet, with Phase II Emergency In-Car Operation Instructions, English, A17.1-1986, A = 247.5 mm
2	MAA250AL9	Tablet, with Phase II Emergency In-Car Operation Instructions, French, B44-00, A = 165 mm
	MAA250AL10	Tablet, with Phase II Emergency In-Car Operation Instructions, French, B44-00, A = 247.5 mm

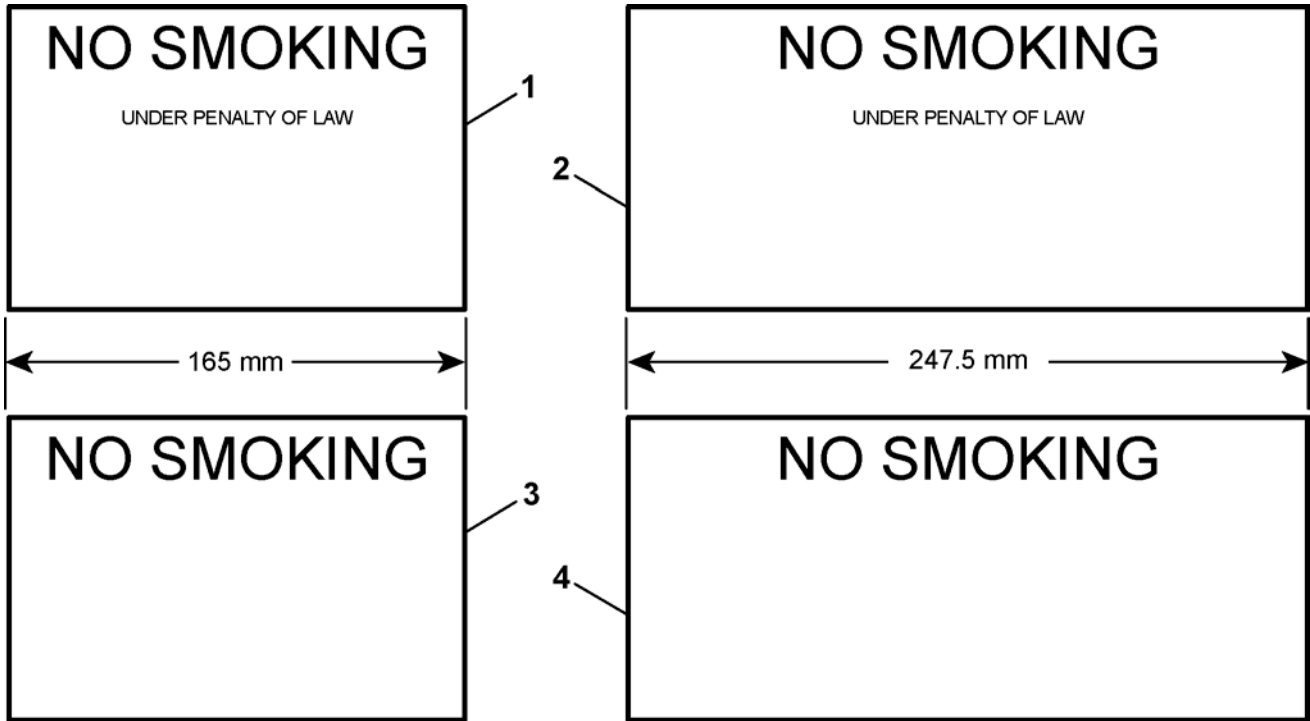

REF. No.	W/O VINTAGE PART No.	DESCRIPTION
1	MAA250AL11	Tablet, No Smoking Under Penalty of Law Message (required for NYC)
2	MAA250AL12	Tablet, No Smoking Under Penalty of Law Message (required for NYC)
3	MAA250AL13	Tablet, No Smoking Message
4	MAA250AL14	Tablet, No Smoking Message

MAA250AP Tablet for NEL Buttons

31-MAA250AC

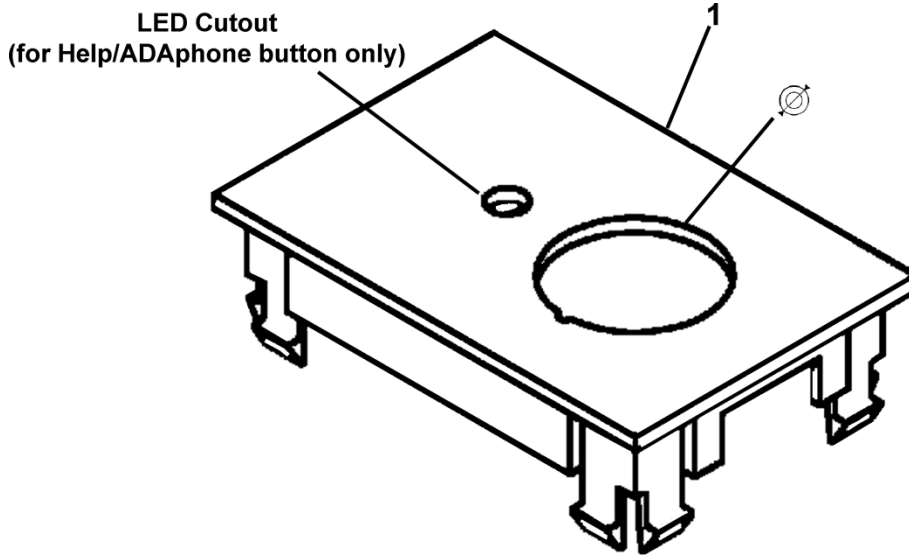

REF. No.	W/O VINTAGE	PART No.	DESCRIPTION	LANGUAGE MARKING
1		MAA250AP4-ENG	Tablet, Alarm Button	English
		MAA250AP4-FR	Tablet, Alarm Button	French
		MAA250AP3-__	Tablet, Call Button, Three Character (as specified)	---
		MAA250AP2-__	Tablet, Call Button, One or Two Character (as specified)	---
		MAA250AP11-BI	Tablet, Call Cancel Button, Bilingual, 27.5 \varnothing	English & French
		MAA250AK11-BI	Tablet, Call Cancel Button, Bilingual, 47.1 mm \varnothing	English & French
		MAA250AP11-ENG	Tablet, Call Cancel Button, 27.5 \varnothing	English
		MAA250AK11-ENG	Tablet, Call Cancel Button, 47.1 mm \varnothing	English
		MAA250AP11-FR	Tablet, Call Cancel Button, 27.5 \varnothing	French
		MAA250AK11-FR	Tablet, Call Cancel Button, 47.1 mm \varnothing	French
		MAA250AP6-FR	Tablet, Door Close Button	French
		MAA250AP6-ENG	Tablet, Door Close Button	English
		MAA250AP5-FR	Tablet, Door Open Button	French
		MAA250AP5-ENG	Tablet, Door Open Button	English
		MAA250AP9-FR	Tablet, Help/ADA Phone Button	French
		MAA250AP9-ENG	Tablet, Help/ADA Phone Button	English
		MAA250AP12-FR	Tablet, Main Landing Car Call Button	French
		MAA250AP12-ENG	Tablet, Main Landing Car Call Button	English
		MAA250AP8-FR	Tablet, Rear Door Close Button	French
		MAA250AP8-ENG	Tablet, Rear Door Close Button	English
	MAA250AP7-FR	Tablet, Rear Door Open Button	French	
	MAA250AP7-ENG	Tablet, Rear Door Open Button	English	

Example: MAA250AP3-12R for three character rear call button