

**Anti-Snag Guard for Car
Rail Bracket**

Spare Parts Leaflet

38-AAA22940BA

November 9, 2011 / Page 1 of 4

**W/O
VINTAGE**

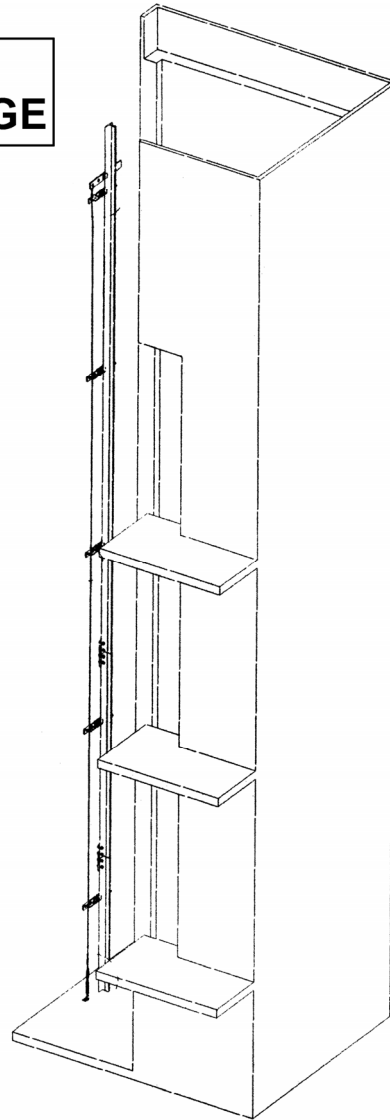

OTIS

Safety First!

SERVICE ENGINEERING
Otis Elevator Company
Bloomfield, Connecticut USA

Leaflet Description

This leaflet provides spare parts information for anti-snag guard for car rail brackets used on LVM, LVML, LVT, Gen2, and Gen2L elevator systems.

Leaflet Revisions

Date Revised	Subject Matter Expert	Reason for Revision
April 22, 2009	Troy Chicoine	New leaflet
November 9, 2011	Gary Mendrala	Added parts for Gen2 & Gen2L

Related Drawings

Drawing No.	Title	Drawing No.	Title
AAA22940BA	Assembly and Arrangement Anti-Snag Guard for Car Rail Bracket	AAA22940AV	Anti-Snag Guard for Cab Rail Bracket Parts
---	---	---	---

Related Documents

Document ID	Title
03-AAA29508C	Gen2L Hoisting Material
38-AAA174ZG	Traveling Cable and Related Sundries
38-AAA174ANT	Cable, Electrical, Flat Traveling Cable

Subject Matter Expert

Name	Department
Gary Mendrala	OSC Service Engineering

About Spare Parts Leaflets...

This document lists the lowest replaceable units (LRUs) for the standard version of the product. The LRUs are chosen by a team of Otis associates representing engineering and manufacturing.

While goal of this document is to make parts identification as easy as possible, the document cannot be all-inclusive. Elevator and escalator contracts classified as "special" or "custom" are not addressed here. For such contracts, please refer to specified information, the contract folder, TIPS, Field Education Articles, Construction Letters, etc. for further information.

If you have any suggestions about this document, please contact the subject matter expert listed on this page.

Anti-Snag Guard for Cab Rail Bracket Parts for LVM, LVML

38-AAA22940BA

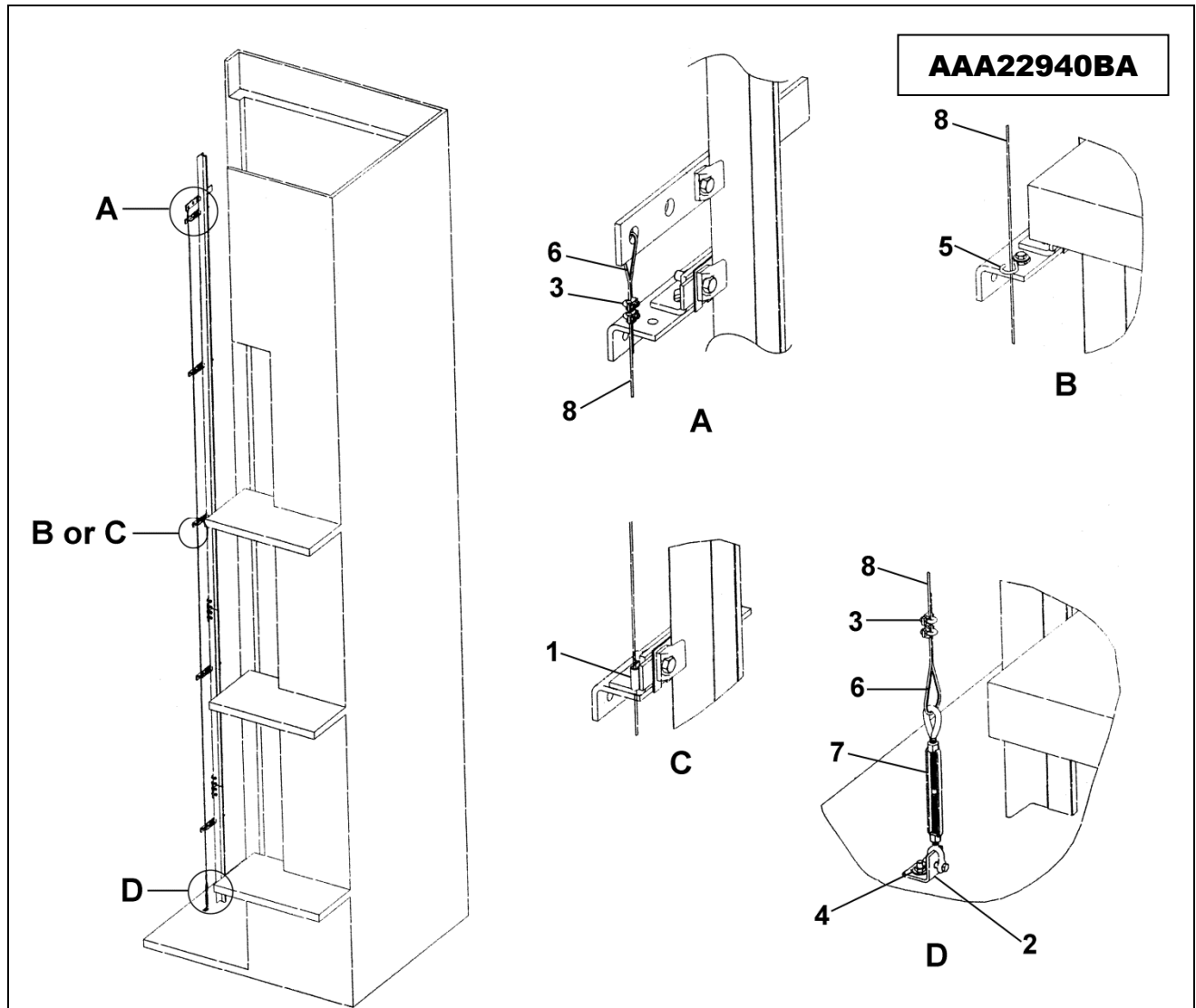

W/O VINTAGE		
REF. No.	PART No.	DESCRIPTION
1	AAA316FWE1	Bracket
2	AAA316HHL1	Bracket
3	336JW1	Clamp
4	54E12	Fastener, Wedge Anchor
5	509W8	S-Hook, 2.25 in. Long, 0.187 in. Wire Diameter
6	AAA00229AAA002	Thimble, Wire Rope
7	AAA485P1	Turnbuckle
8	AAA712Y2	Wire Rope, 1/8 in. Diameter (specify length in feet)

38-AAA22940BA

Anti-Snag Guard for Cab Rail Bracket Parts for Gen2, Gen2L

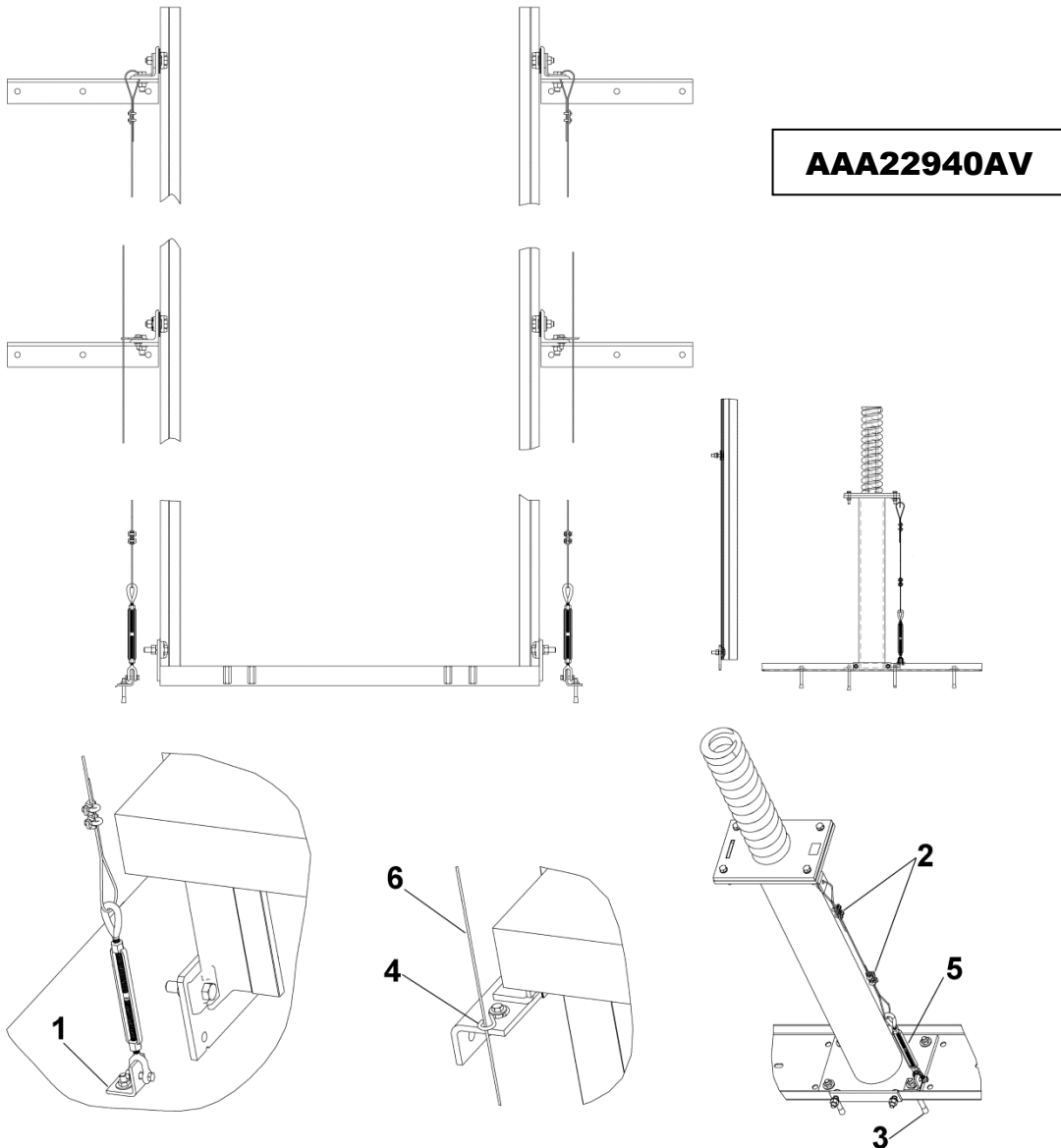

W/O VINTAGE		
REF. No.	PART No.	DESCRIPTION
1	AAA316HHL1	Bracket
2	336JW1	Clamp
3	54E12	Fastener, Wedge Anchor
4	509W1	S-Hook, 1.75 in. Long, 0.25 in. Wire Diameter
	509W8	S-Hook, 2.25 in. Long, 0.187 in. Wire Diameter
5	AAA485P1	Turnbuckle
6	AAA712Y2	Wire Rope, 1/8 in. Diameter (specify length in feet)