

# SPL 50-BAA26220J - Safeties Device - K2/K3 - 30 - NAO

Unpublished Work - © Otis Elevator Company. Any unauthorized reproduction, disclosure, or distribution of copies or content by any person of any portion of this work may be a violation of Copyright Law of the United States of America. All rights reserved.

Page 1 - (MISSING STEP DEVICE) MS1/MS2

December 1990

## SEGURANCA PARA FALTA DE DEGRAU ( MISSING STEP DEVICE ) MS1/MS2

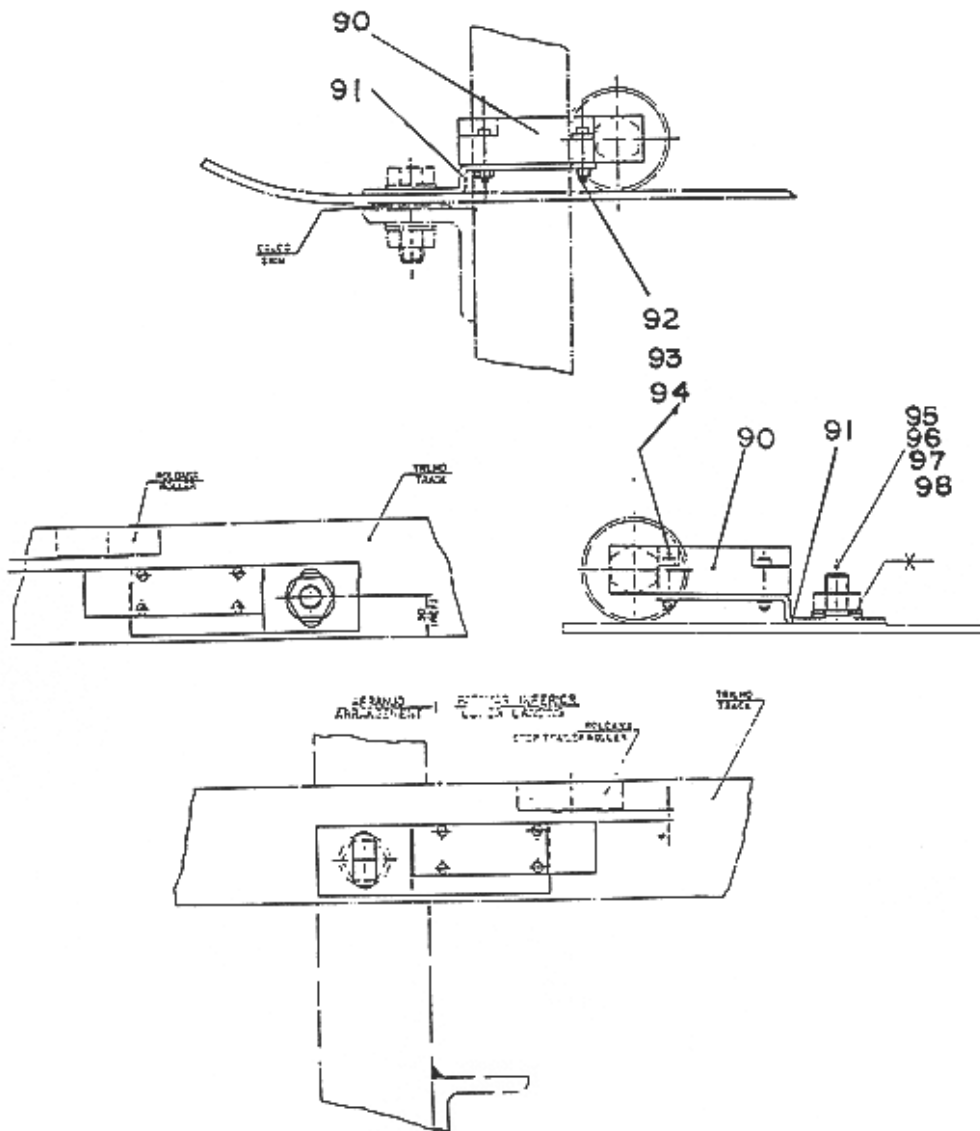

**SPL 50-BAA26220J - Safeties Device - K2/K3 - 30 - NAO**

**Page 2**

<b>REF. NUM.</b>	<b>DESCRIPTION</b>	<b>PART OR ML</b>
<b>90</b>	(SENSOR)	BAA645A1
<b>91</b>	(BRACKET)	BAA316JH1
<b>92</b>	(BOLT)	40CH182100
<b>93</b>	(NUT)	43SD182100
<b>94</b>	(SPRING WASHER)	03PG180600
<b>95</b>	(STUD)	BO81BJ8
<b>96</b>	(NUT)	43SD182500
<b>97</b>	(SPRING WASHER)	03PG181200
<b>98</b>	(WASHER)	03PB181900