

Handrail Drive Chain  
 508NCE / 512NCE /  
 515NPE-S / 515NPE-L

Spare Parts Leaflet

51-DAA332K

May 5, 2009 / Page 1 of 4

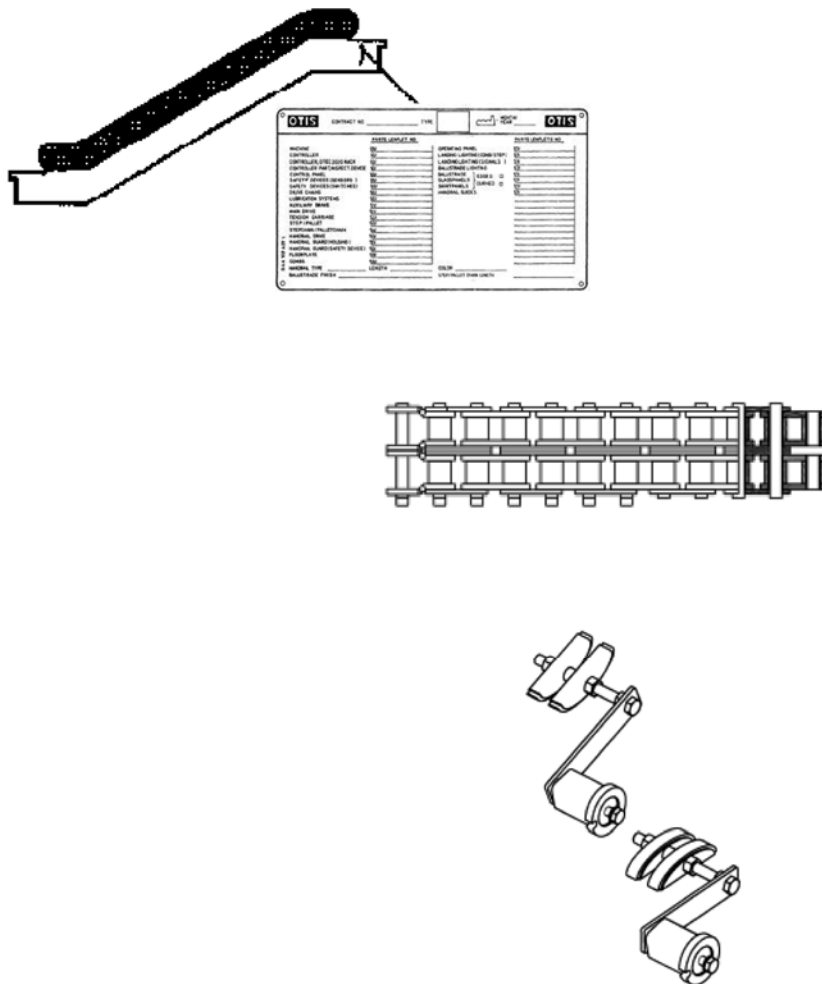

Unpublished Work—© Otis Elevator Co.

**OTIS**

Safety First!

SERVICE ENGINEERING  
 Otis Elevator Company  
 SIT GUANGZHOU

## Leaflet Description

Escalator Handrail Drive Chain—508NCE / 512NCE / 515NPE-S / 515NPE-L

### Leaflet Revisions

Date Revised	Subject Matter Expert	Reason for Revision
May 5, 2009	Wu, Muke	Original Document

### Related Drawings

Drawing No.	Title	Drawing No.	Title
DAA332K	Handrail Drive Chain		

### Related Documents

Document ID	Title
BOM DAA332K	Handrail Drive Chain

### Subject Matter Expert

Name	Department
Wu, Muke	SIT-GUANGZHOU

### About Spare Parts Leaflets...

This document lists the lowest replaceable units (LRUs) for the standard version of the product. The LRUs are chosen by a team of Otis associates representing engineering and manufacturing.

While goal of this document is to make parts identification as easy as possible, the document cannot be all-inclusive. Elevator and escalator contracts classified as “special” or “custom” are not addressed here. For such contracts, please refer to specified information, the contract folder, TIPs, Field Education Articles, Construction Letters, etc. for further information.

If you have any suggestions about this document, please contact the subject matter expert listed on this page.

# Handrail Drive Chain

51-DAA332K

508NCE / 512NCE / 515NPE-S / 515NPE-L

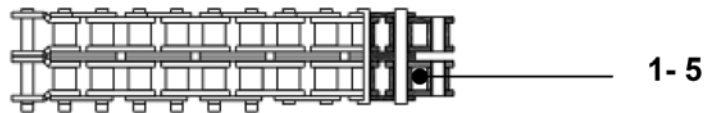

REF. No.	PART No.	DESCRIPTION		
	DAA332K			
1	DAA332K1	Driving Chain Main Drive to Handrail Drive, 20A-2, Duplex	512NCE/515NPE-S/515NPE-L, 30°	EN115 2/3/4 Flat Step
2	DAA332K2	Driving Chain Main Drive to Handrail Drive, 16B-2, Duplex	508NCE, 30°	JIS 1.5/2 Flat Step
3	DAA332K3	Driving Chain Main Drive to Handrail Drive, 16B-2, Duplex	508NCE, 30°	JIS 3 Flat Step
4	DAA332K4	Driving Chain Main Drive to Handrail Drive, 16B-2, Duplex	508NCE, 30°	EN115 2/3 Flat Step
5	DAA332K5	Driving Chain Main Drive to Handrail Drive, 16B-2, Duplex	508NCE, 35°	EN115 2 Flat Step

508NCE / 512NCE / 515NPE-S / 515NPE-L

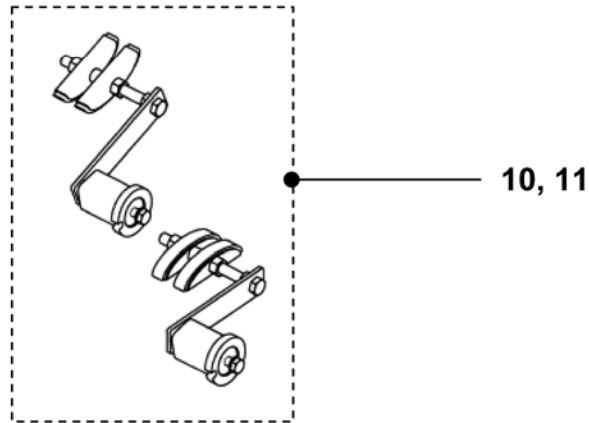
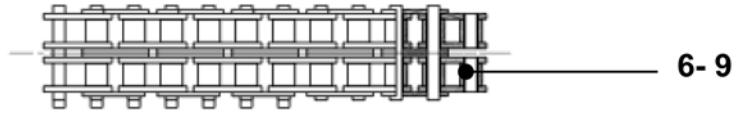

DAA332K				
REF. No.	PART No.	DESCRIPTION		
6	DAA332K6	Driving Chain Main Drive to Handrail Drive, 16B-2, Duplex	508NCE, 35°	EN115 3 Flat Step
7	DAA332K7	Driving Chain Main Drive to Handrail Drive, 16B-2, Duplex	508NCE, 30°	ANSI 2 Flat Step
8	DAA332K8	Driving Chain Main Drive to Handrail Drive, 16B-2, Duplex	508NCE, 30°	ANSI 3 Flat Step
9	DAA332K9	Driving Chain Main Drive to Handrail Drive, 20A-2, Duplex	512NCE, 30°	ANSI 2/3 Flat Step
10	DAA385NNX1	Chain Tensioner	508NCE	
11	GAA385JS1	Chain Tensioner	512NCE/515NPE-S/515NPE-L	