

SPL 51-GO9704BY - Escalator 510 Aux. Brake Calliper Type

Unpublished Work - © Otis Elevator Company. Any unauthorized reproduction, disclosure, or distribution of copies or content by any person of any portion of this work may be a violation of Copyright Law of the United States of America. All rights reserved.

July 1994

Page 1

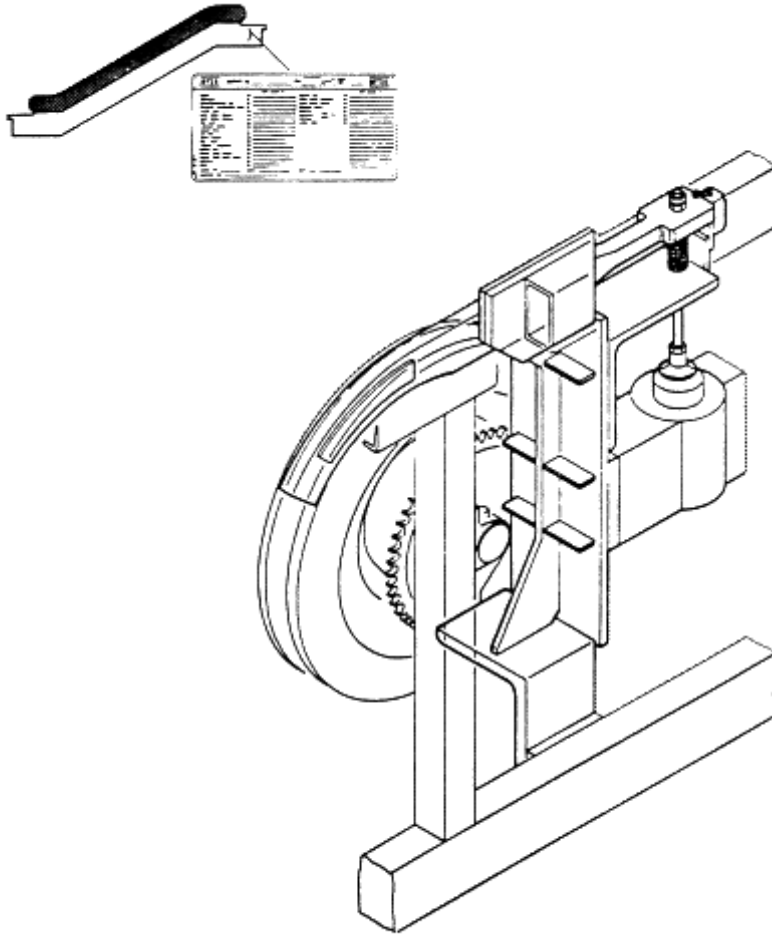

SPL 51-GO9704BY - Escalator 510 Aux. Brake Calliper Type

Page 2

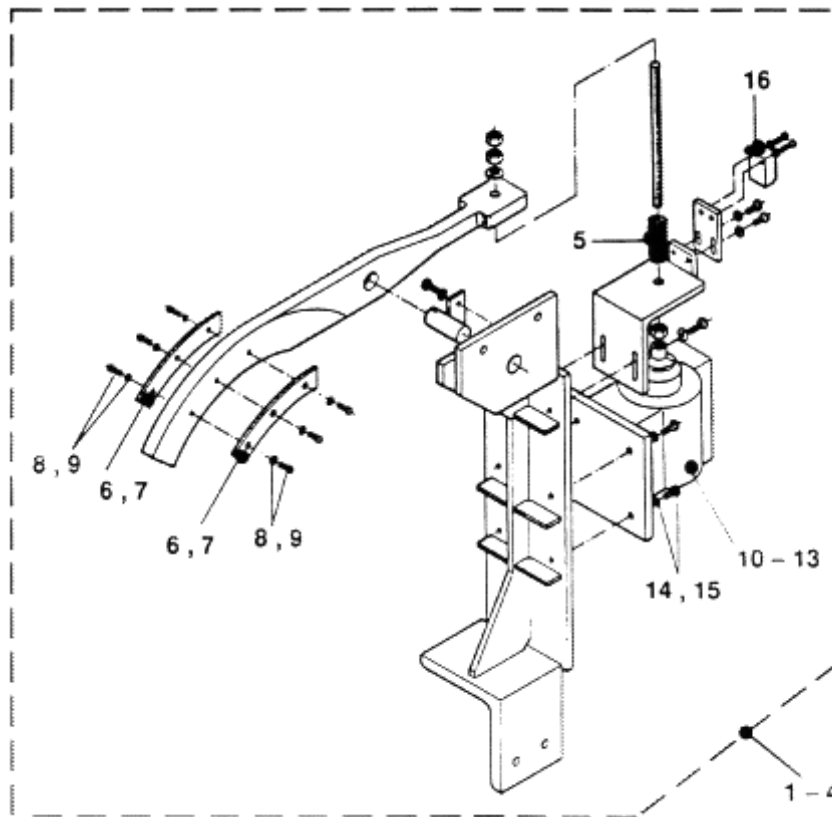

| VINTAGE G.01 | | |
|--------------|-------------|---|
| REF.NO. | PART OR ML | DESCRIPTION |
| 1 | GO9704BY4 | Calliper brake 24 Volt AC (~) |
| 2 | GO9704BY5 | Calliper brake 110 Volt AC (~) |
| 3 | GO9704BY6 | Calliper brake 220 Volt AC (~) |
| 4 | GO9704BY8 | Calliper brake 48 Volt AC (~) |
| 5 | ----- | Spring 10 x 50 110 DIN 2098 |
| 6 | GO 416 H 1 | Brake lining w Asbestos |
| 7 | GO416H2 | Brake lining w/o Asbestos |
| 8 | ----- | Hex.socket head cap screw w reduced height of head M 6 X 12 DIN 7984 |
| 9 | ----- | Spring washer A 6 DIN 137 |
| 10 | GO330AH1 * | Brake magnet 24 Volt AC (~) |
| 11 | GO330AH2 * | Brake magnet 110 Volt AC (~) |
| 12 | GO330AH3 * | Brake magnet 220 Volt AC (~) |
| 13 | GO330AH4 * | Brake magnet 48 Volt AC (~) |
| 14 | ----- | Hex. head screw M10 X 30 (DIN 933) ISO 4017 |
| 15 | ----- | Sing.c.spring washer A 10 DIN127 |
| 16 | GO 177 CC 1 | Switch |
| | GAA177FG1 * | Switch |