

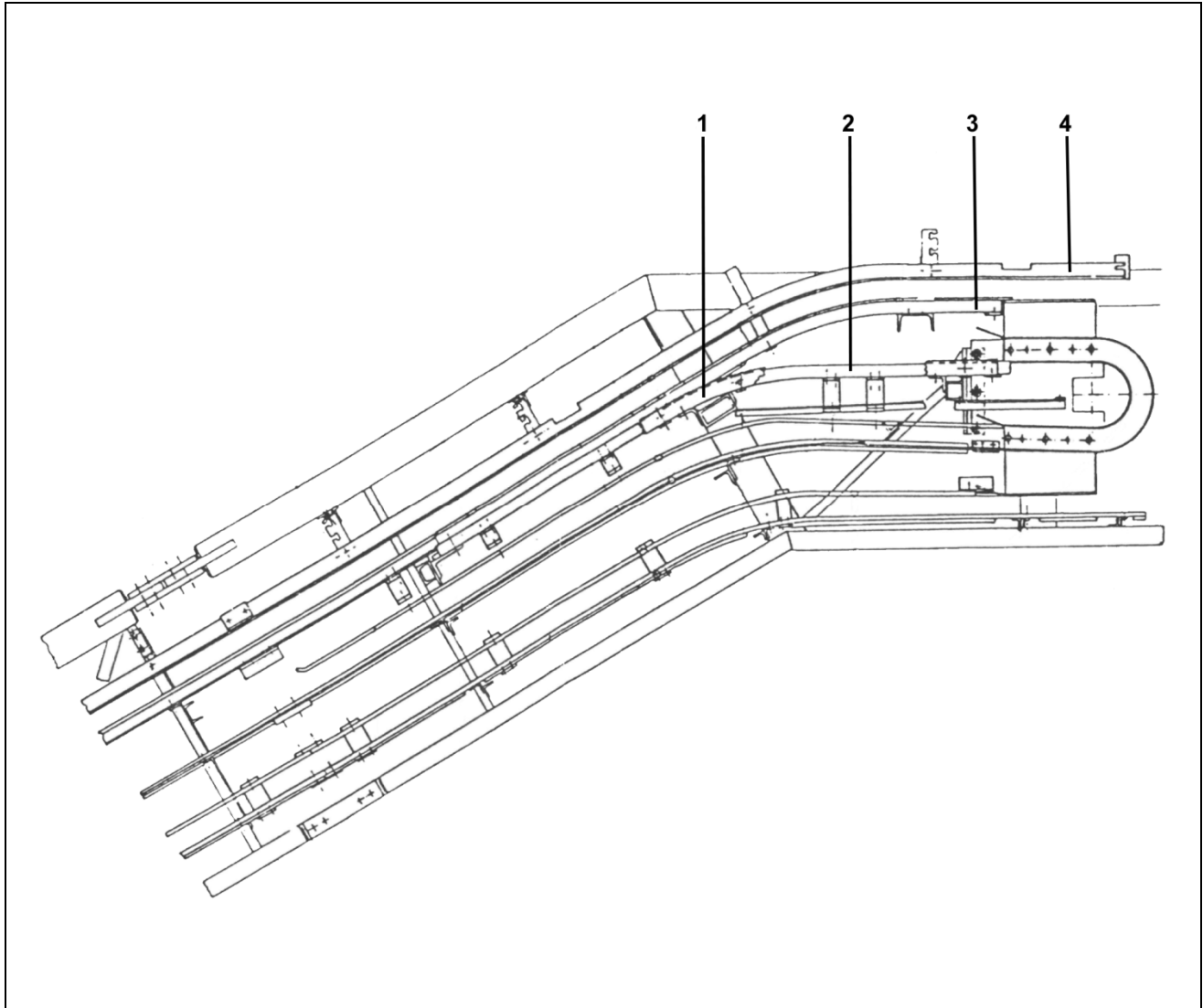

506 Track, Upper Landing, Passenger Line



52-EA2029

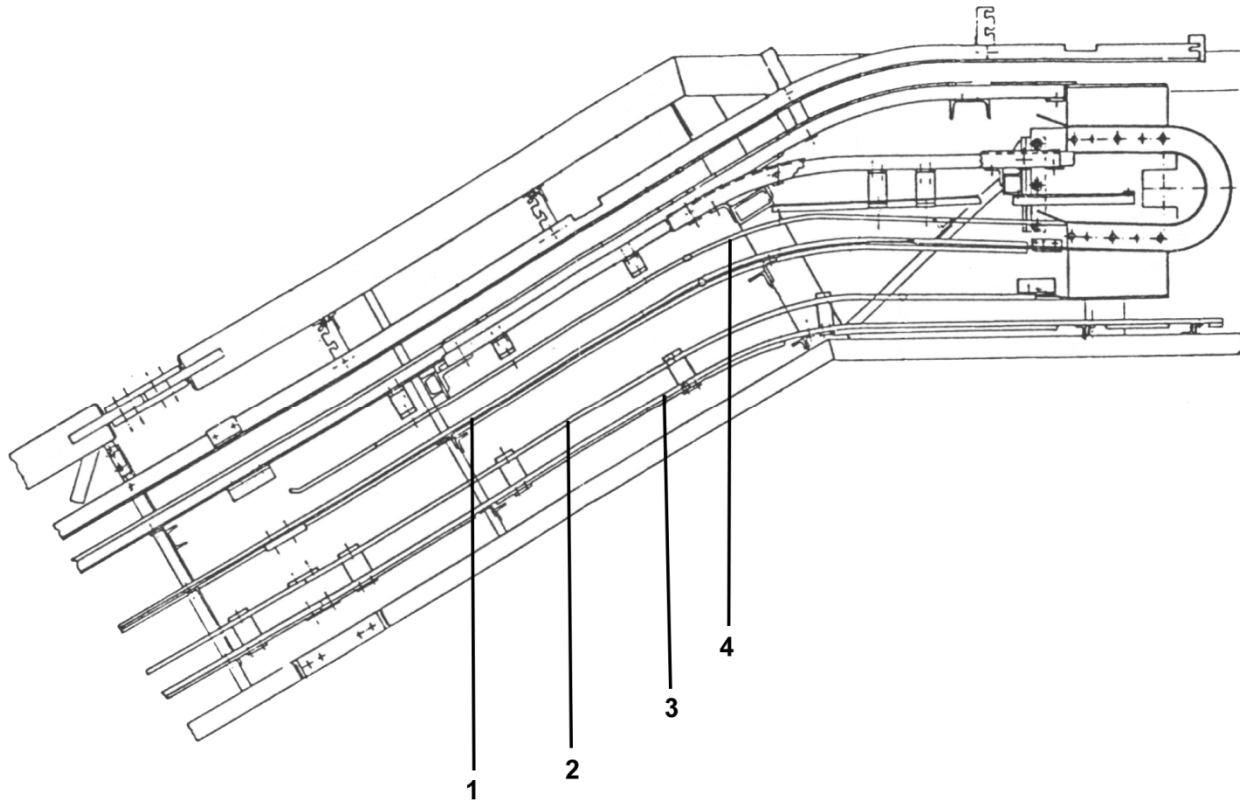

W/O VINTAGE				
REF. No.	PART No.		DESCRIPTION	Approx. Length (mm)
	L 	R 		
1	GO483XG1 GO483XG5	GO483XG2 GO483XG6	Step Upthrust, Curved	1255
2	GO483XF1	GO483XF2	Track, Step Roller	2100
3	GO483XE1	GO483XE2	Track, Step Chain Roller	2153
4	EA2029-373 EA2029-401	EA2029-374 EA2029-402	Track, Step Chain Roller Upthrust	3297

506 Track, Upper Landing, Return Line





REF. No.	W/O VINTAGE		DESCRIPTION	Approx. Length (mm)
	PART No.			
	L 	R 		
1	GO483XH1	GO483XH2	Track, Step Roller	2679
2	EA2029-28		Track, Step Chain Roller Upthrust	2485
3	EA2029-35	EA2029-36	Track, Step Chain Roller	3000
4	EA2029-29	---	Track, Step Roller Upthrust (Left Side Only)	2378

506 Track, Lower Landing, Passenger Line

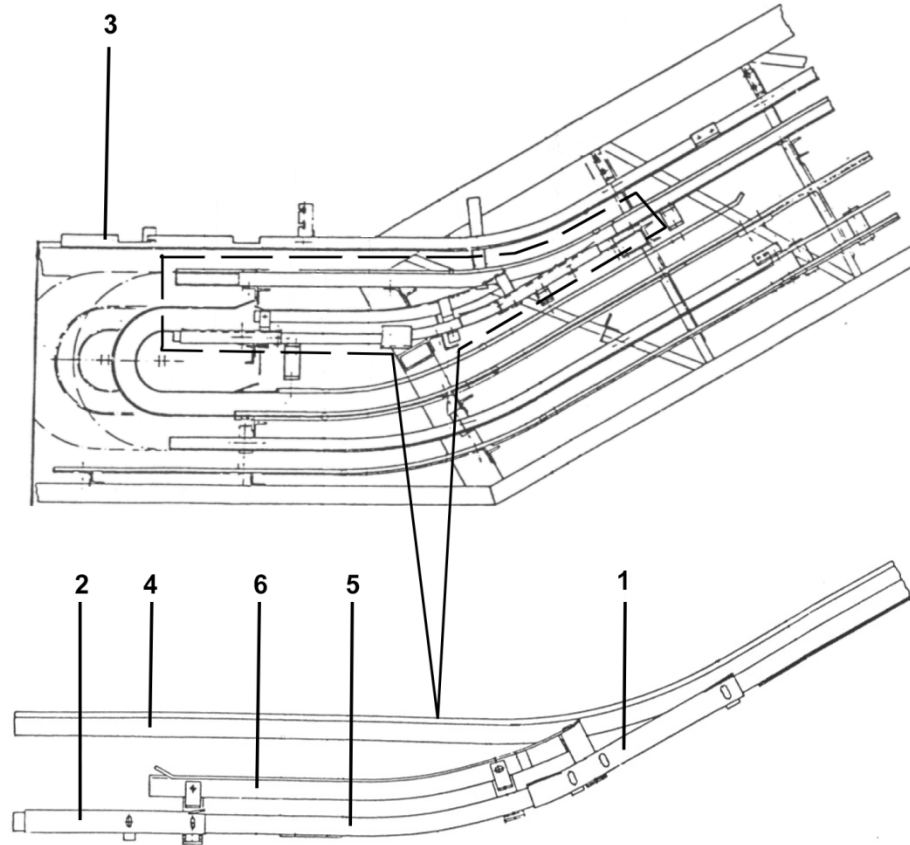

52-EA2029





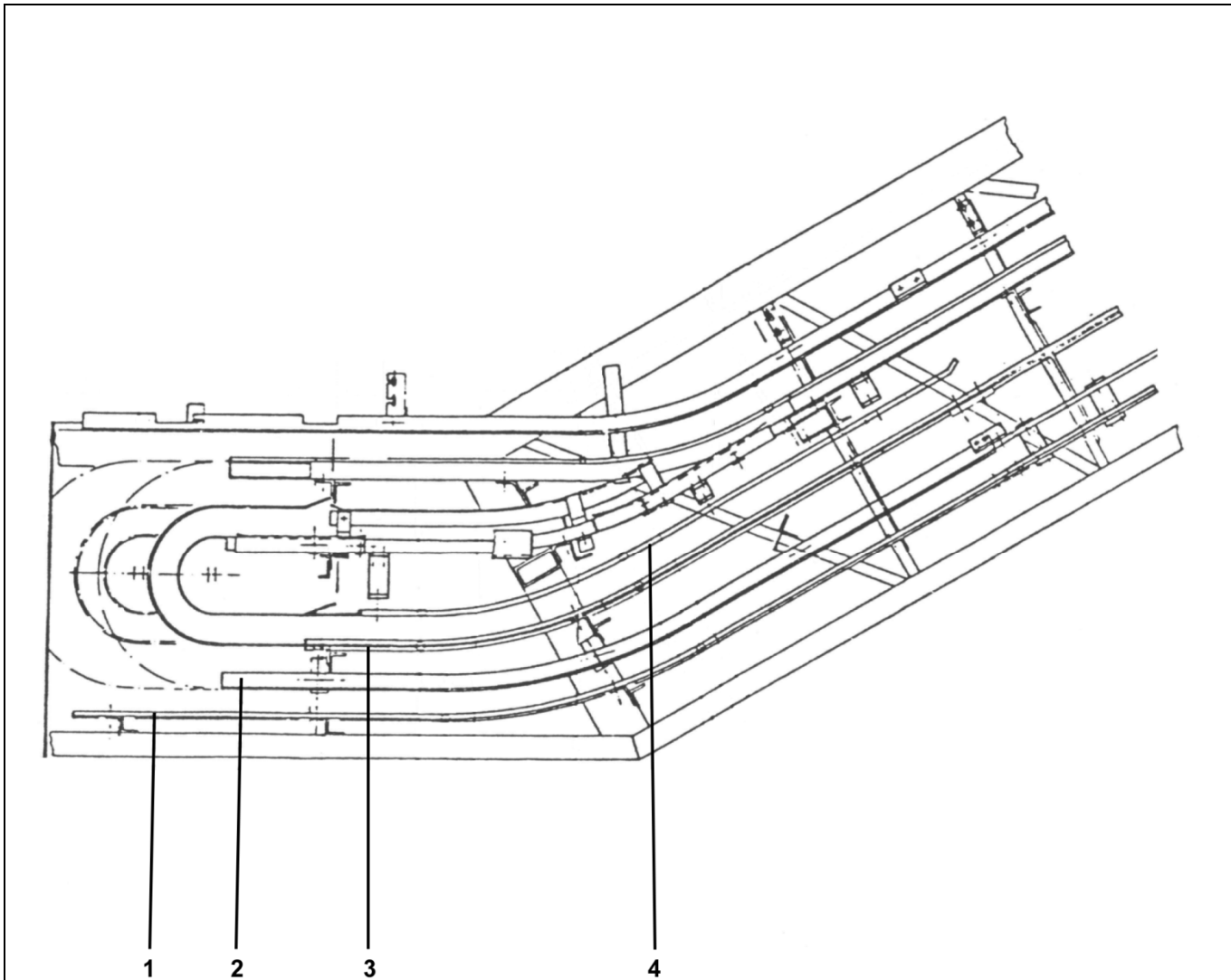

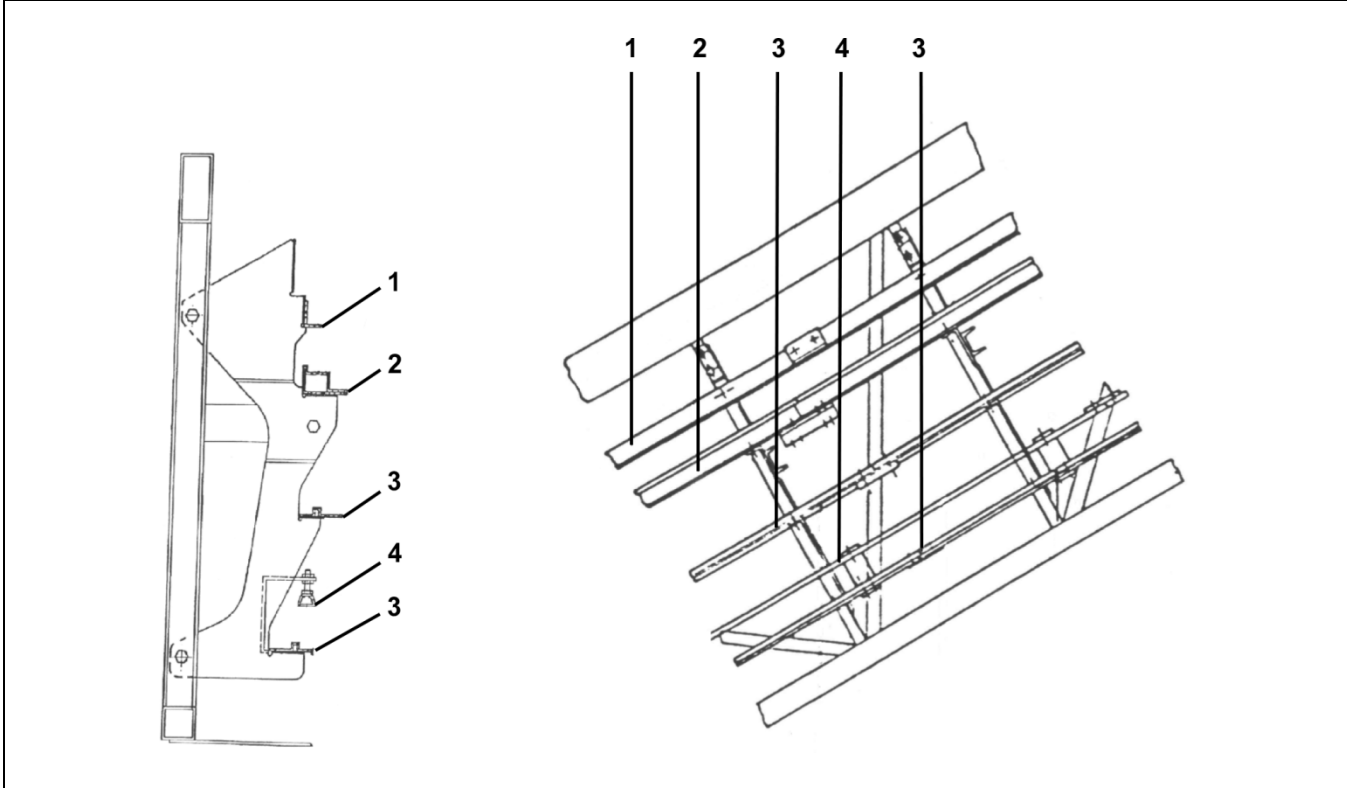

W/O VINTAGE				
REF. No.	PART No.		DESCRIPTION	Approx. Length (mm)
	L 	R 		
1	GO483ABB4 GO483ABB5	GO483ABB2 GO483ABB6	Step Upthrust, Curved	491
2	GO483ABC4 YYGO483ABC1	GO483ABC2 YYGO483ABC2	Step Upthrust, Straight	370
3	EA2029-375 EA2029-417	EA2029-376 EA2029-418	Track, Step Chain Roller Upthrust	2387
4	GO483WW1	GO483WW2	Track, Step Chain Roller	1594
5	GO483WX1	GO483WX2	Track, Step Roller	1643
6	GO483AAY4 GO483AAY5	GO483AAY2 GO483AAY6	Track, Step Roller Upthrust Assembly Complete with Spring and Brackets	885

506 Track, Lower Landing,
Return Line





REF. No.	W/O VINTAGE		DESCRIPTION	Approx. Length (mm)
	PART No.			
	L 	R 		
1	GO483XC1	GO483XC2	Track, Step Chain Roller	2662
2	EA2029-17 EA2029-415	EA2029-18 EA2029-416	Track, Step Chain Roller Upthrust	2289
3	GO483XA1	GO483XA2	Track, Step Roller	2213
4	EA2029-25	---	Track, Step Roller Upthrust (Left Only)	1707

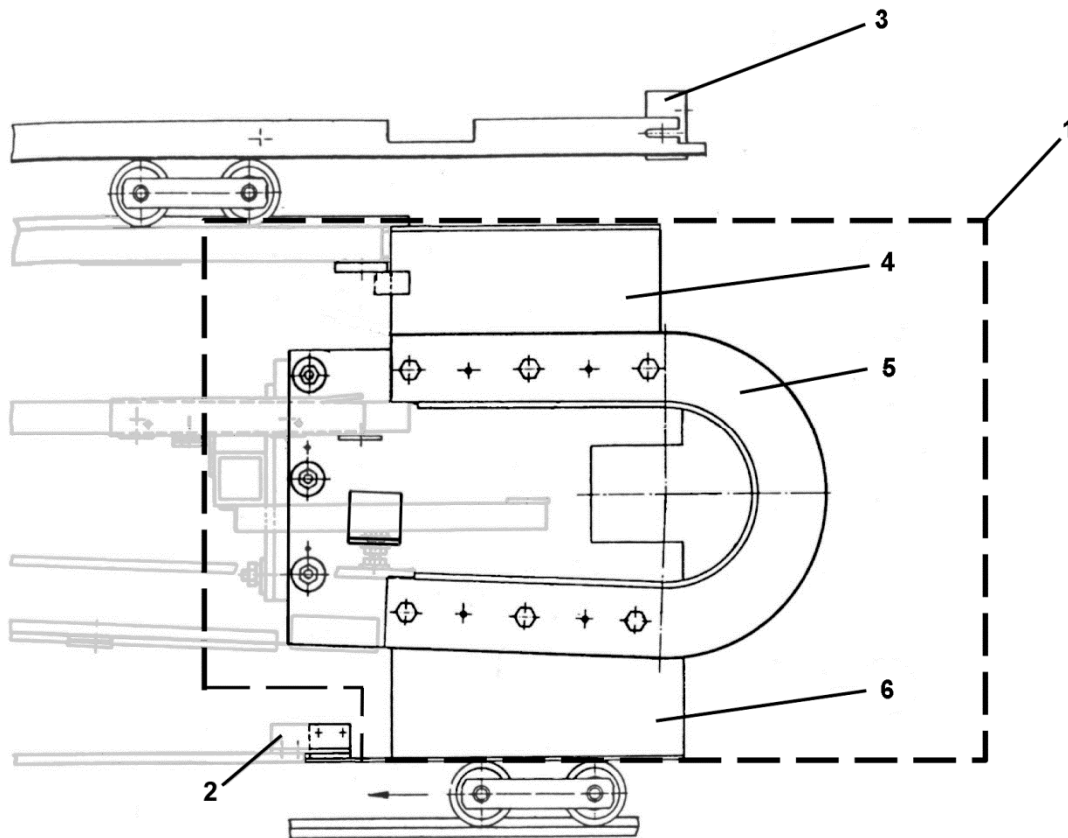

W/O VINTAGE		Description	Approx. Length	PROFILE
REF. No.	PART No.			
	L  R 			
1	GO483XP_		Varies	
	YXGO483AEB1 See NOTE	YXGO483AEB2 See NOTE	3660	
2	GO483XT_		Varies	 GOA50FK
	156-141 See NOTE		6000	
3	GO483XS_ GO483XR_		Varies	 GO50AAD
	1S-GO50AAD6000 See NOTE		6000	
4	GO483PX_		Varies	 GO50WH
	GO50WH1 See NOTE		6000	

NOTE: This part to be cut to suit during installation.





W/O VINTAGE				
REF. No.	PART No.		DESCRIPTION	Approx. Length (mm)
	L 	R 		
1	EA2029-339	EA2029-340	Assembly, Step Roller Return	---
2	EA2029-33	EA2029-34	Angle	105
3	GO272DAM1	GO272DAM2	Bracket, Angle	58
4	GO483YC1	GO483YC2	Track, Transition Passenger	315
5	GO483WR1		Track, Step Roller Turnaround	515
	GAA483AXY1	GAA483AXY2		
6	EA2029-341 EA2029-437	EA2029-342 EA2029-438	Track, Transition Return	315

506 Track, Hardware,
Upper Landing

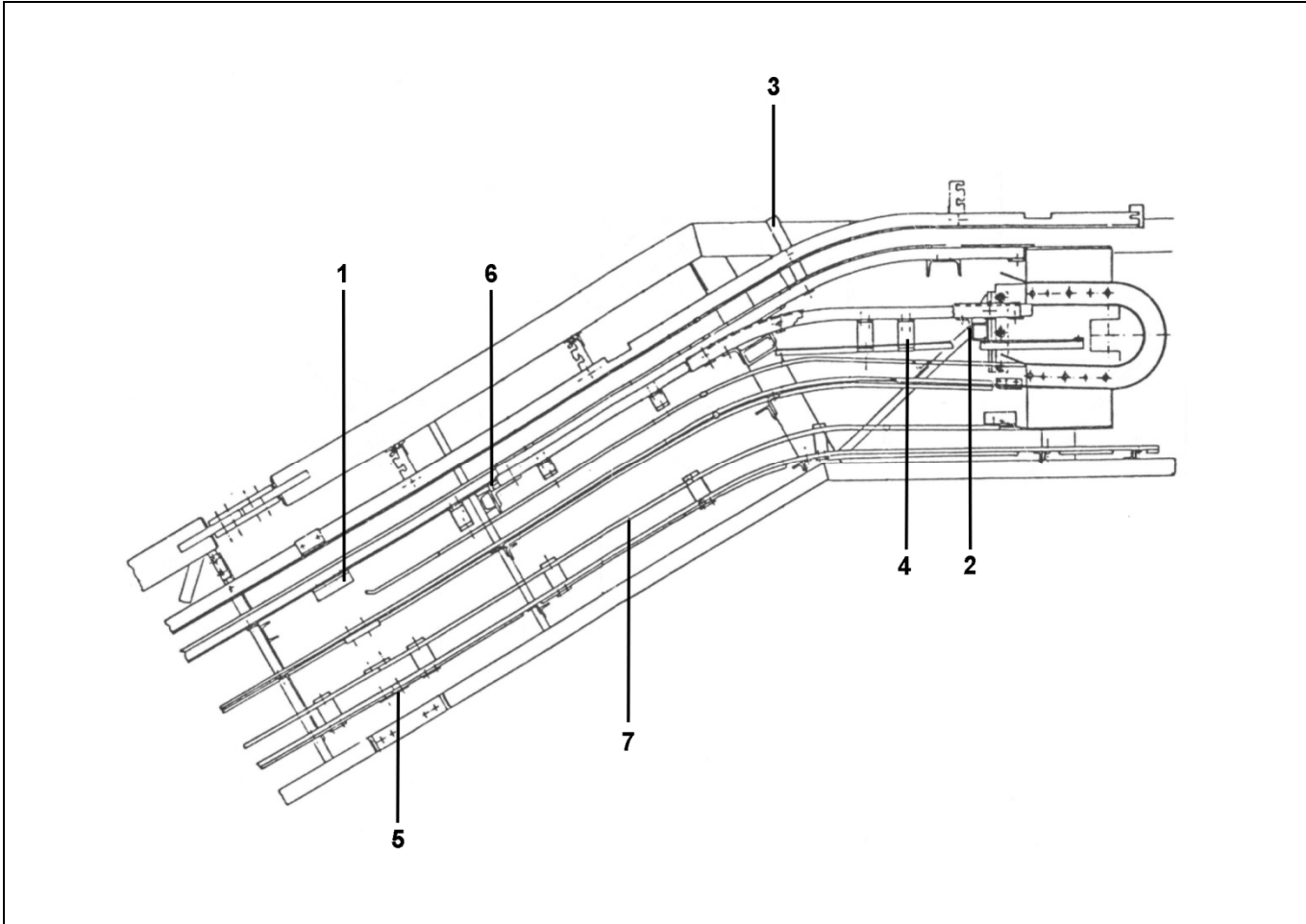

52-EA2029

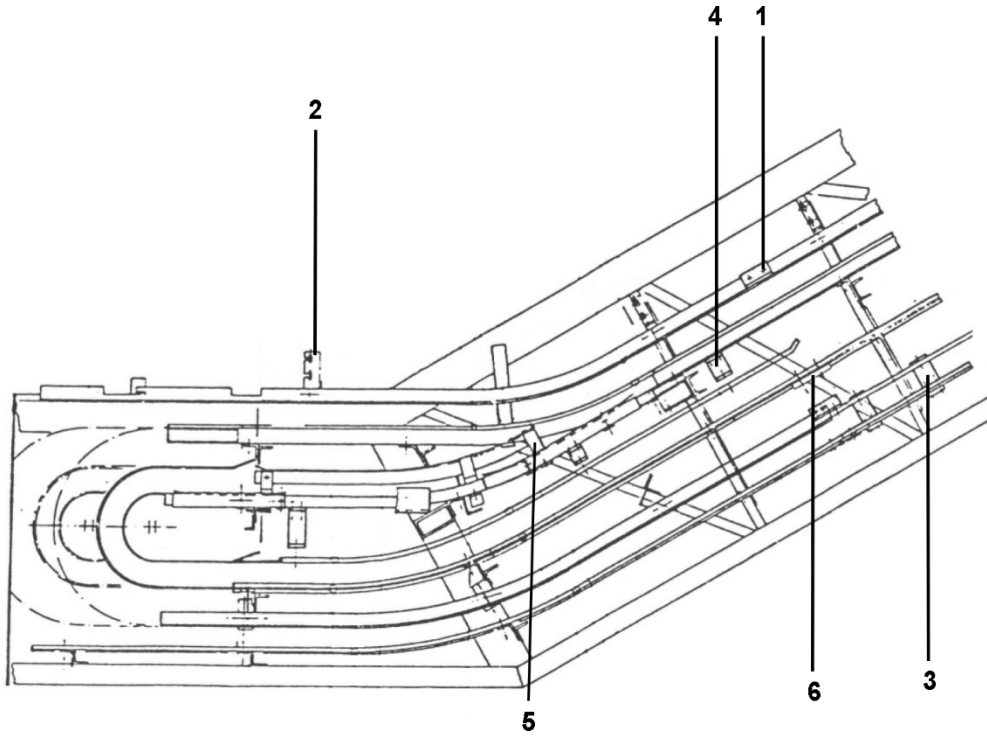

REF. No.	W/O VINTAGE		DESCRIPTION
	PART No.		
	L 	R 	
1	GO272CBN1		Angle, Track Splice
2	GO283ADV1		Angle, Track Holder
3	GO283ADW1 GO283ADW2		Bracket, Upthrust Support
4	EA2029-41 EA2029-410		Holder, Track
5	GO386BRG3 GO386BRG4		Plate, Splice for Return Track
6	GOA298HD1		Spacer
7	GO298AAR1 DAA298AC1		Strip, Upthrust Track Splice

506 Track, Hardware,
Lower Landing



W/O VINTAGE			DESCRIPTION
REF. No.	PART No.		
	L 	R 	
1	YXGO272CBT1		Angle, Splice for Upthrust
2	GO316BMM1 GO316BMM3		Holder
3	EA2029-30		Holder, Upthrust Track
4	EA2029-42 EA2029-411		Holder, Track
5	GO180AAA3	GO180AAA4	Holder, Track
6	GO386BRG1 GO386BRG2		Plate, Return Track Splice