

SPL 57-UT2179 - Transformer Fluorescent Lamps Otis 606

Unpublished Work - © Otis Elevator Company. Any unauthorized reproduction, disclosure, or distribution of copies or content by any person of any portion of this work may be a violation of Copyright Law of the United States of America. All rights reserved.

June 1983

Page 1

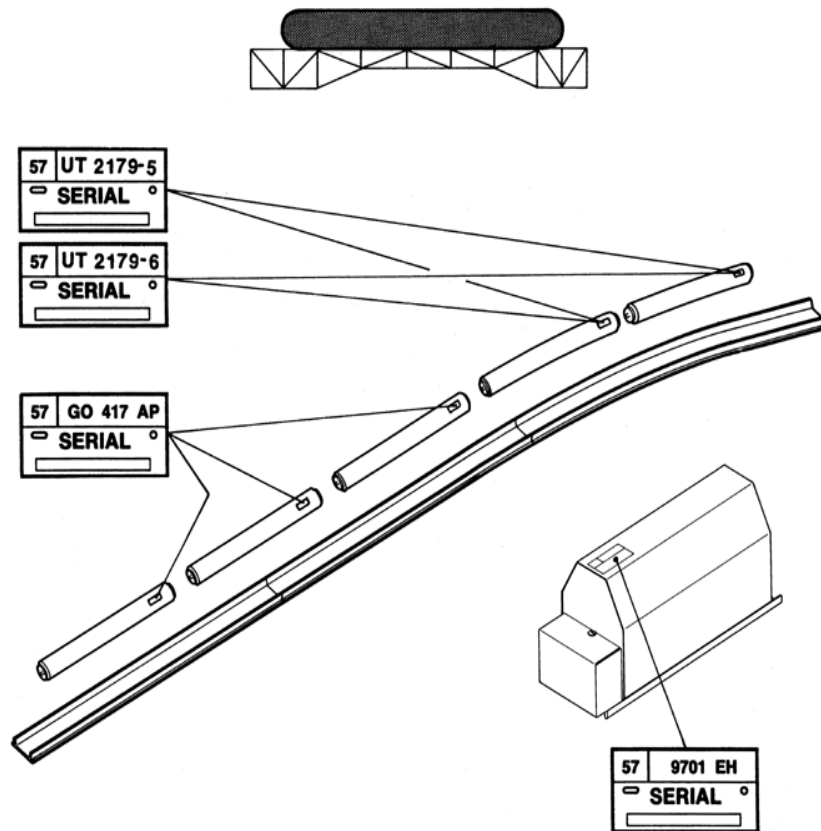

SPL 57-UT2179 - Transformer Fluorescent Lamps Otis 606

Page 2 - Transformer Fluorescent Lamps Otis 606

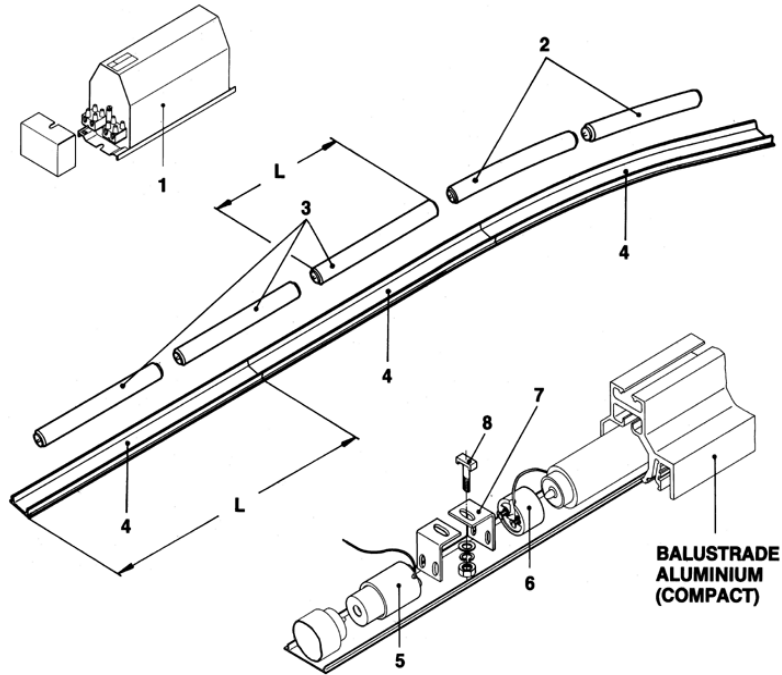

Page 2 - Transformer Fluorescent Lamps Otis 606

REF. No.	PART No.	DESCRIPTION
	G.01	
1	9701EH13	Transformer prim. 220 VAC--sec. 600 VAC
2	UT2179-5	Fluorescent Lamp for Trav-O-Lator 10 degrees
	UT2179-6	Fluorescent Lamp for Trav-O-Lator 12 degrees
3	GO417AP1	Fluorescent Lamp L = 1000 mm
	GO417AP2	Fluorescent Lamp L = 1100 mm
	GO417AP3	Fluorescent Lamp L = 1175 mm
	GO417AP4	Fluorescent Lamp L = 1250 mm
	GO417AP5	Fluorescent Lamp L = 1325 mm
	GO417AP6	Fluorescent Lamp L = 1400 mm
4	1S-GO50AAR	Cover for Fluorescent Lamps for Balustrade, Aluminum L = mm Cut to Length
5	GO6644B1	Tension Socket
6	GO6644B2	Socket
7	GO283AEF1	Angle
8	GO63AD1	T-head Screw M5

SPL 57-UT2179 - Transformer Fluorescent Lamps Otis 606

Page 3 - Transformer Fluorescent Lamps Otis 606

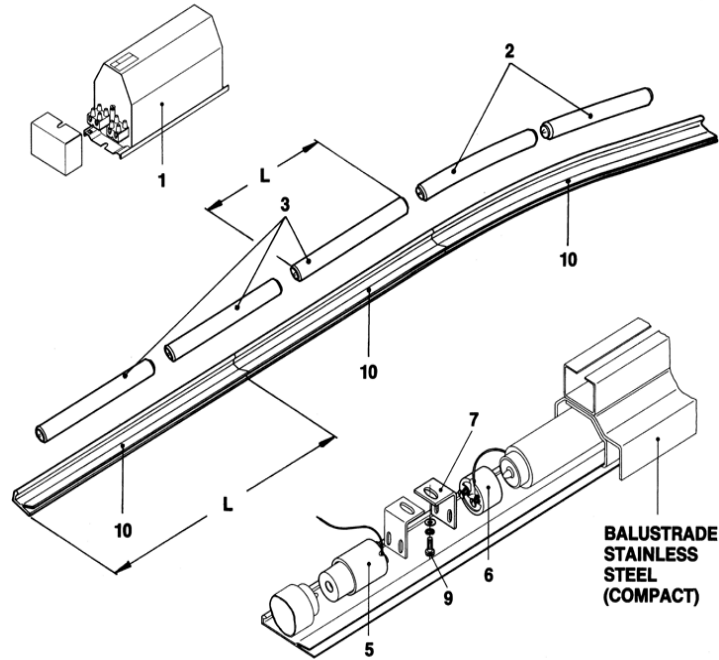

Page 3 - Transformer Fluorescent Lamps Otis 606

G.01		
REF. No.	PART No.	DESCRIPTION
1	9701EH13	Transformer prim. 220 V AC_sec. 600 V AC
2	UT2179-5	Fluorescent Lamp for Trav-O-Lator 10°
	UT2179-6	Fluorescent Lamp for Trav-O-Lator 12°
3	GO417AP1	Fluorescent Lamp L = 1000 mm
	GO417AP2	Fluorescent Lamp L = 1100 mm
	GO417AP3	Fluorescent Lamp L = 1175 mm
	GO417AP4	Fluorescent Lamp L = 1250 mm
	GO417AP5	Fluorescent Lamp L = 1325 mm
	GO417AP6	Fluorescent Lamp L = 1400 mm
5	GO6644B1	Tension Socket
6	GO6644B2	Socket
7	GO283AEF1	Angle
9	20719	Hex. Screw M5 x 20 DIN 933
10	1S-GOA50ABF	Cover for Fluorescent Lamps for Balustrade Stainless Steel L = mm Cut to Length