

# Hydraulic Elevator with Type 5A Hydraulic Machine

## Spare Parts Leaflet C-1027

May 18, 2022 / Page 1 of 14

# OBSOLESCENCE NOTICE

The product covered in this SPL has been designated as obsolete and is no longer supported. See TIP 32.2-1, *Obsolete Components*, for potential upgrade. Replacement lower level parts listed within and unique to this design are not being restocked when depleted. Some of these parts, depending on availability and other factors, may be quoted through Customer Service, but most will have extended lead times and increased cost due to low volume production.

New York Design

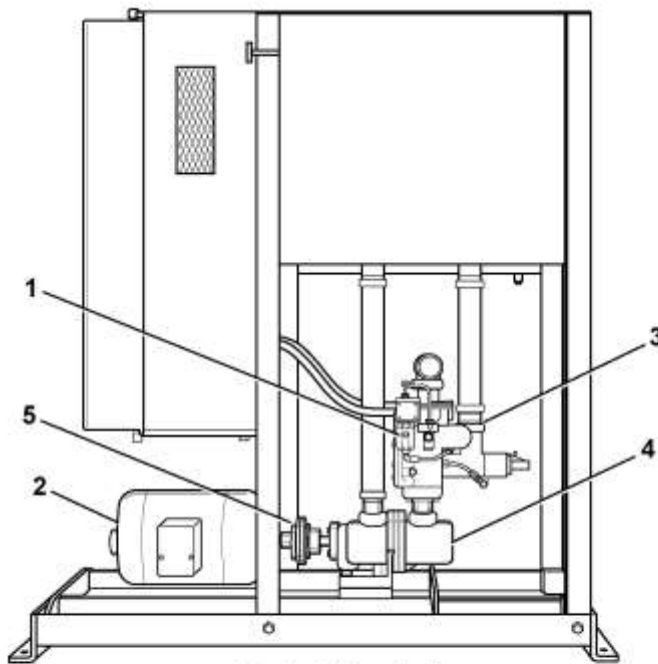

Typical Illustration

1. Pilot Valve	Page 4
2. Motor	Page 6
3. Manifold Valve	Pages 7, 8, 9, 10
4. Pump	Page 11
5. Coupling	Page 13

NOTE: For lubrication and hydraulic oil, see Lubrication Chart, Form #2422H.

Order Forms O-351A, O-352C, O-352E & O-352F

# OTIS

This document does not contain any technical data subject to EAR or ITAR

**SERVICE ENGINEERING**  
**Otis Elevator Company**  
**Bloomfield, Connecticut USA**

Unpublished Work—© Otis Elevator Co.; 2022

**Leaflet Description**

This leaflet provides information for replacement parts for the New York Design hydraulic elevator, also known as plunger electric elevator, with type 5A machine, direct driven pump and manifold valve.

**Leaflet Revisions**

<b>Date Revised</b>	<b>Subject Matter Expert</b>	<b>Reason for Revision</b>
February 1, 1963	Works Service Dept., Yonkers, NY	New SPL
April 1, 1997	Technical Publications Dept., Otis Service Center	Update parts numbers
July 31, 2003	Troy Chicoine	Change pump part number, p. 12
May 18, 2022	Brian Regan	Updated document template and obsolescence info

**Related Drawings**

<b>Drawing No.</b>	<b>Title</b>	<b>Drawing No.</b>	<b>Title</b>
---	---	---	---

**Related Documents**

<b>Document ID</b>	<b>Title</b>
Order Form O-351A	---
Order Form O-352C	---
Order Form O-352E	---
Order Form O-352F	---

**Subject Matter Expert**

<b>Name</b>	<b>Department</b>
Brian Regan	OSC Service Engineering

**About Spare Parts Leaflets...**

This document lists the lowest replaceable units (LRUs) for the standard version of the product. The LRUs are chosen by a team of Otis associates representing engineering and manufacturing.

While goal of this document is to make parts identification as easy as possible, the document cannot be all-inclusive. Elevator and escalator contracts classified as “special” or “custom” are not addressed here. For such contracts, please refer to specified information, the contract folder, TIPs, Field Education Articles, Construction Letters, etc. for further information.

If you have any suggestions about this document, please contact the subject matter expert listed on this page.

# Type 5A Hydraulic Machine

**C-1027**

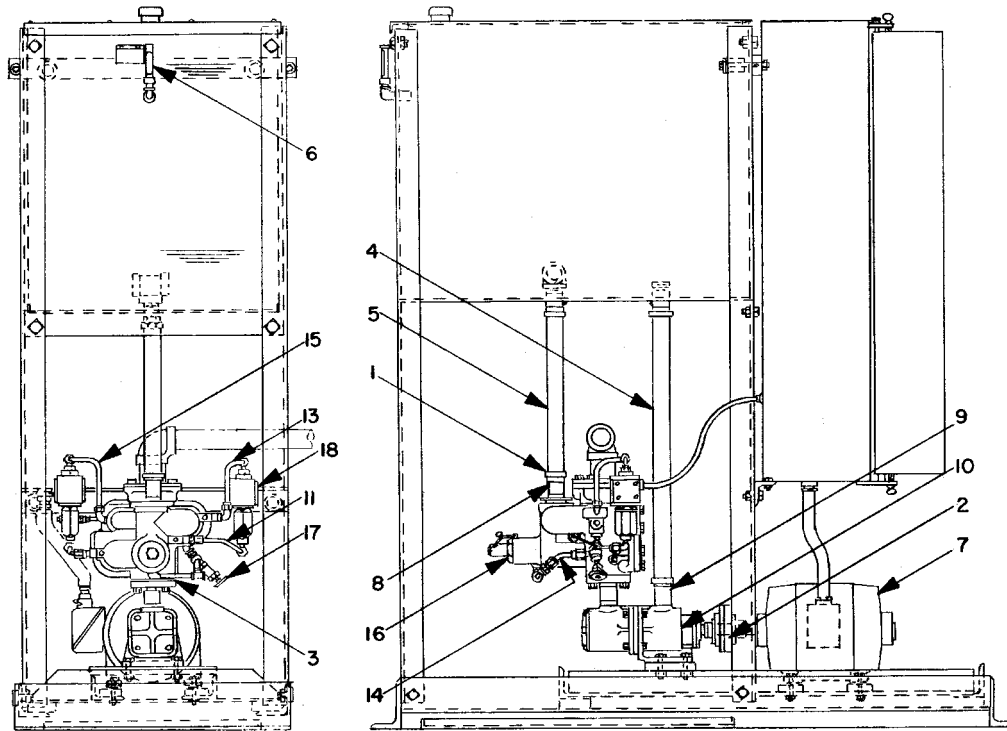

## Type 5A Hydraulic Machine

Order Form O-352F

M.L. 2084E2, 6962D2 & 2223A20, 21

W/O VINTAGE		
REF. No.	PART No.	DESCRIPTION
---	B254D1	Bonnet, Oil Filter (for Oil Tank)- not shown
1	336DY1	Clamp, Hose
2	---	Coupling (for details, see Page 13)
3	376AA2	Gasket, 4-1/2" x 4-1/2" x 1/16" thick, Vellumoid (Flange to Pump)
4	134A7	Hose, 2-1/4" I.D., 16-1/2" Long (Tank to Pump)
5	134A7	Hose, 2-1/4" I.D., 16-1/2" Long (Tank to Valve)
6	269AW1	Indicator, Oil
7	-	Motor, Single Speed (for details, see Page 6)
8	441AH3	Pipe, Half Nipple, 2" std., 6" Long (Hose to Valve)
9	441AH8	Pipe, Half Nipple, 2" std., 16-5/8" Long (Hose to Pump)
10	---	Pump (for details, see Page 11)
11	136AH2	Tubing, with Fittings
12	136AJ2	Tubing, with Fittings
13	136AJ4	Tubing, with Fittings
14	136AK2	Tubing, with Fittings
15	136AL2	Tubing, with Fittings
16	---	Valve, 2" Manifold (for details, see Pages 7 through 10)
17	---	Valve, Manual Lowering, Angle Screwed, 400# bronze
18	6941A1	Valve, Pilot (for details, see Page 4)

**6941A Pilot Valve**

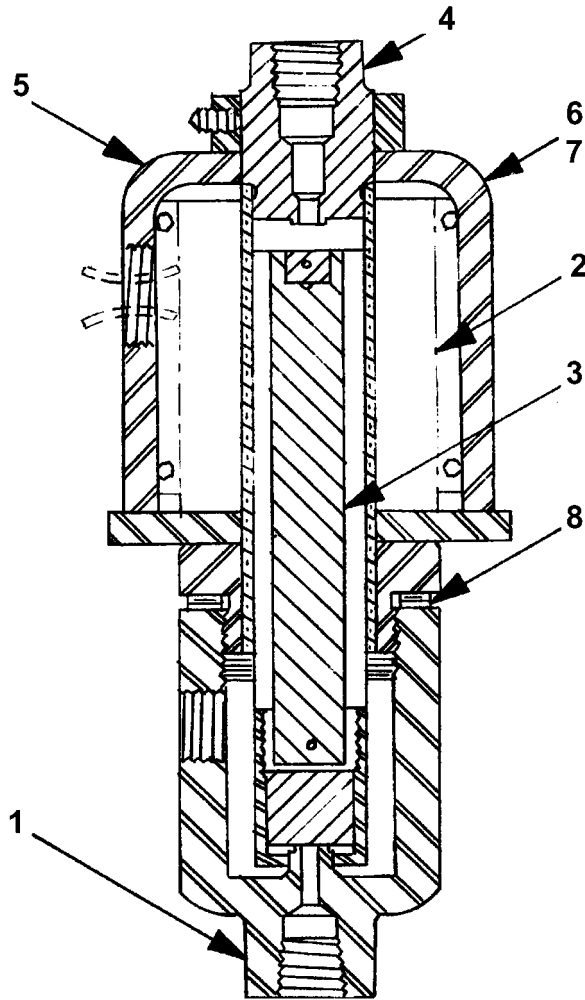

**Pilot Valve**  
for Leveling and Lowering Valves  
M.L. 6941A1

W/O VINTAGE		
REF. No.	PART No.	DESCRIPTION
1	330BF1	Case, Pilot Valve
2	222CV6	Coil, Magnet, 7300 Turns, No. 31 Wire
3	400BJ2	Core, Moveable
4	400BK1	Core, Stationary
5	374JG1	Frame, Magnet
6	386JR10	Plate, 2-3/8 in. Wide x 2-5/8 in. Long x 1/16 in. Thick
7	96H138	Rod, 1/8 in. Diameter, 3-1/4 in. Long (for Plates)
8	255CJ1	Shim, Laminum, (3) .003 in. Laminations, Brass

# 6962E Check Valve

**C-1027**

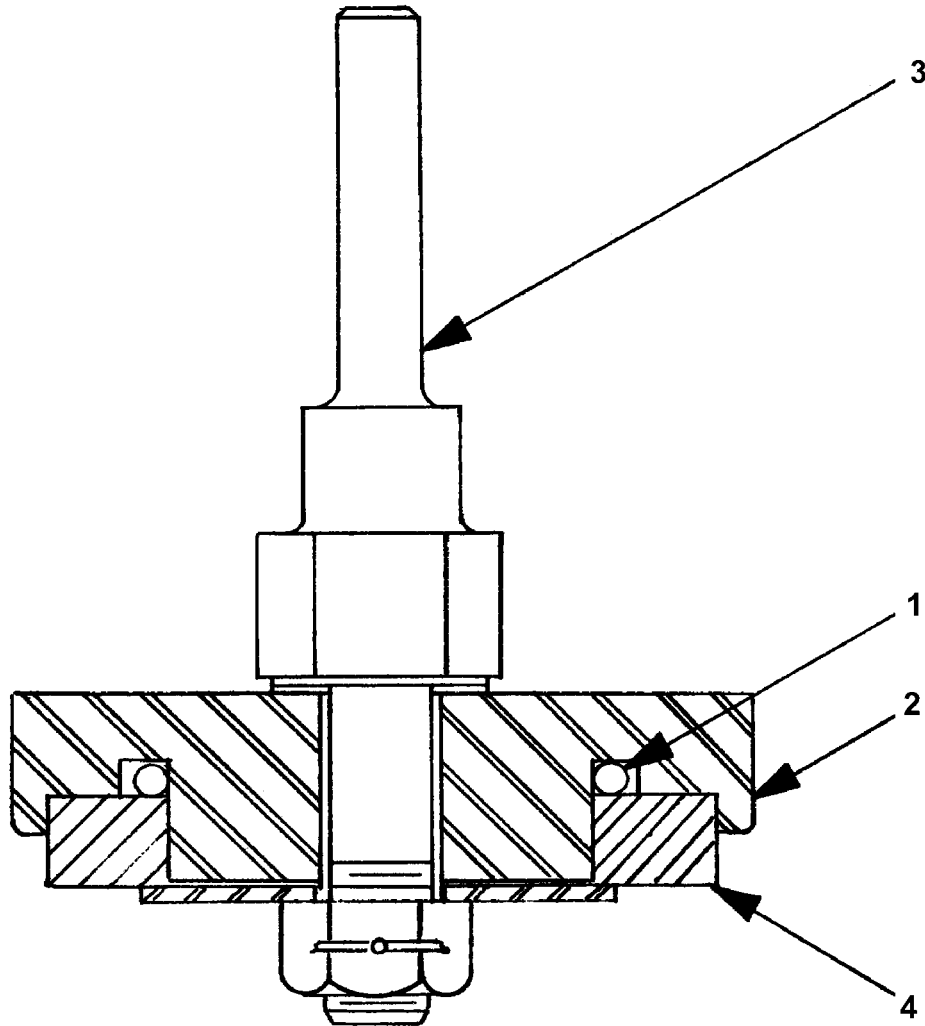

**Check Valve**  
M.L. 6962E1

	<b>W/O VINTAGE</b>	
<b>REF. No.</b>	<b>PART No.</b>	<b>DESCRIPTION</b>
1	182H2	Packing, "O" Ring
2	445AW1	Plunger
3	95BP2	Rod, Shouldered
4	129BL2	Washer, Valve Disc

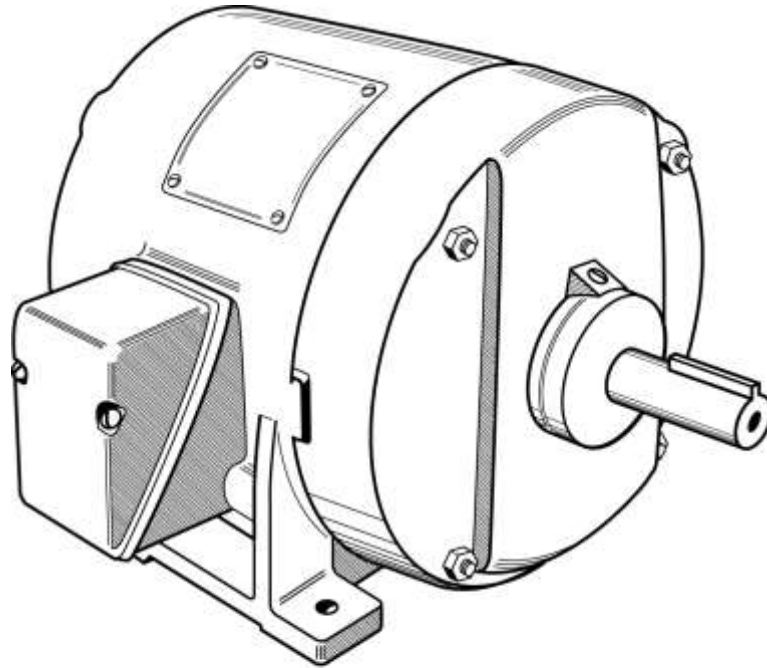
**Single Speed Motors**

**Single Speed Motors**  
3 Phase, 60 Cycles, A.C., 3600 RPM

<b>W/O VINTAGE</b>			
<b>PART No.</b>	<b>VOLTS</b>	<b>NAME PLATE H.P.</b>	<b>FRAME No.</b>
6333BV1	208	5	213
A6333P2	220/440 ( <i>specify voltage</i> )	5	213
A6333P3	550	5	213
A6333R1	208	7-1/2	215
A6333R2	220/440 ( <i>specify voltage</i> )	7-1/2	215
A6333R3	550	7-1/2	215
A6333T1	208	10	254U
A6333T2	220/440 ( <i>specify voltage</i> )	10	254U
A6333T3	550	10	254U

# 2223B "2" Manifold Valve

**C-1027**

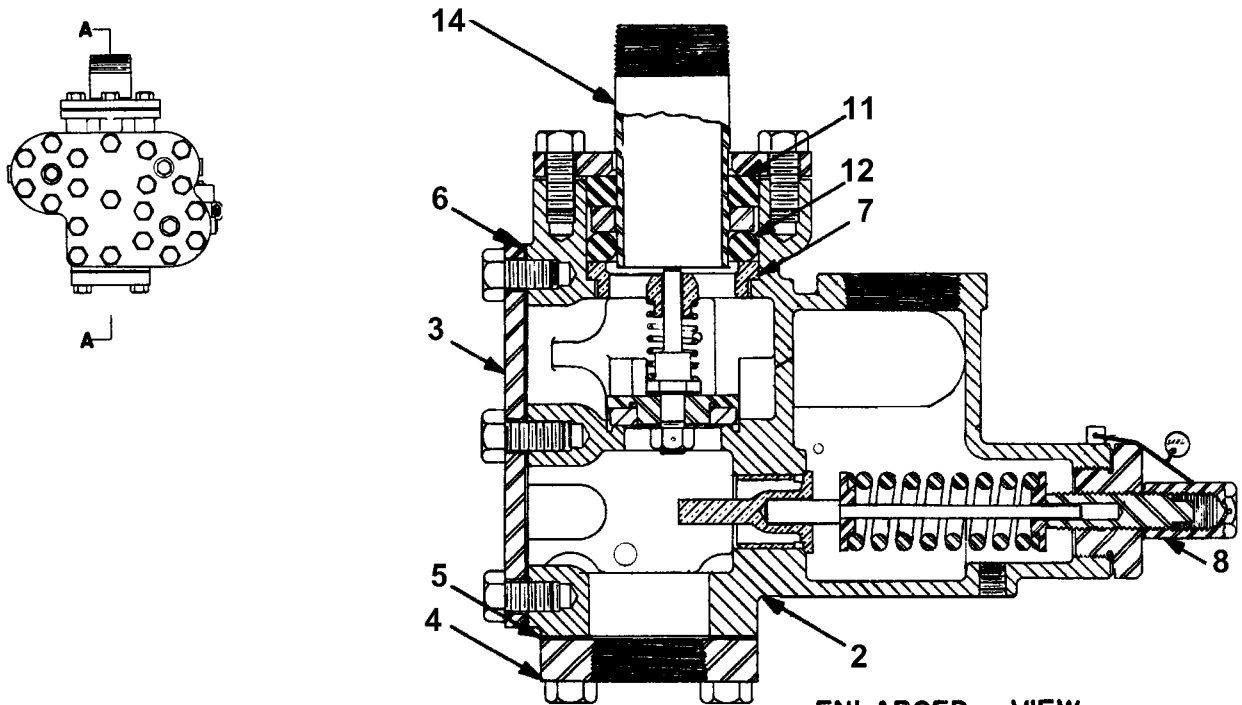

## 2" Manifold Valve

ENLARGED VIEW  
SECTION A-A

M.L. 2223B9, 2223B10, 2223B19 & 2223B23  
Order Form O-352C & O-352E

	W/O VINTAGE	
REF. No.	PART No.	DESCRIPTION
2	---	Case, Valve (If necessary to order, give elevator sales number and size of manifold valve).
3	346AAB1	Cover, Valve
4	441AB2	Fitting, Flange, 2 in. Pipe Tap
	441AB3	Fitting, Flange, 1-1/2 in. Pipe Tap
5	376AA2	Gasket, 4-1/2 in. square x 1/16 in. Thick, Vellumoid (for Fitting)
6	376DD1	Gasket, Vellumoid (for Cover)
7	385GS1	Guide, Check Valve
8	72BY1	Nut, Cap, 1 in. Hex, 3/4 in. Tap (for screw Ref. 26)
11	182G2	Packing, Ring, 2-5/16 in. I.D., 3-9/16 in. O.D., 5/8 in. Thick, Neoprene
12	182F2	Packing, Ring, 5/8 in. Diameter, 9 in. Long (form at assembly)
14	377BE2	Pipe, 2 in. std., 5 in. Long

(Continued on next page)

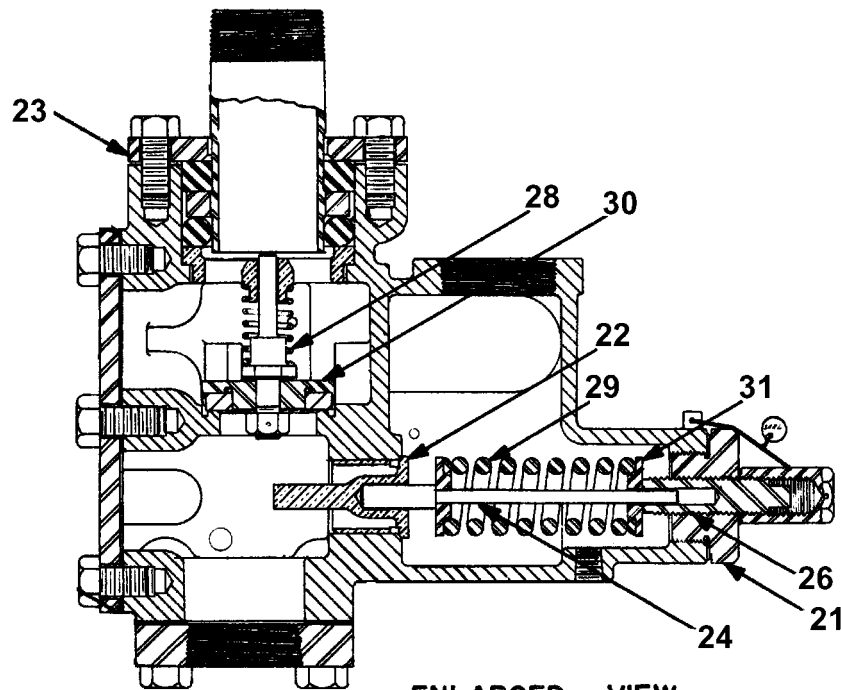
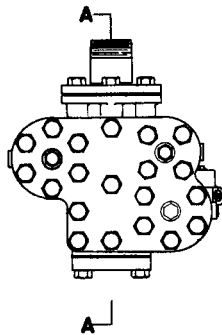
**C-1027****2223B "2" Manifold Valve****ENLARGED VIEW  
SECTION A-A****2" Manifold Valve**

M.L. 2223B9, 2223B10, 2223B19 & 2223B23  
Order Form O-352C & O-352E

REF. No.	W/O VINTAGE PART No.	DESCRIPTION
21	441AR1	Plug, 2-3/8 in. Hex (for Case)
22	445AV1	Plunger, Relief Valve
23	172JG1	Ring, Clamp (for Case)
24	96BE2	Rod, Relief Valve Piston, 5/16 in. Diameter, 6-5/8 in. Long
26	124BK2	Screw, 3/4 in. Thread, 3-1/8 in. Long (for Plug)
28	90VB7	Spring, Compression, 27/32 in. I.D., 2-3/8 in. Long, 5-3/4 Active Turns (for Check Valve)
29	90BD4	Spring, Compression, 1-5/8 in. O.D., 4-1/2 in. Long, 7-1/2 Active Turns (for Relief Valve)
30	6962E1	Check Valve (for details, see Page 5)
31	133G6	Washer, Spring Seat

(Continued on next page)



# 2223B "2" Manifold Valve

**C-1027**

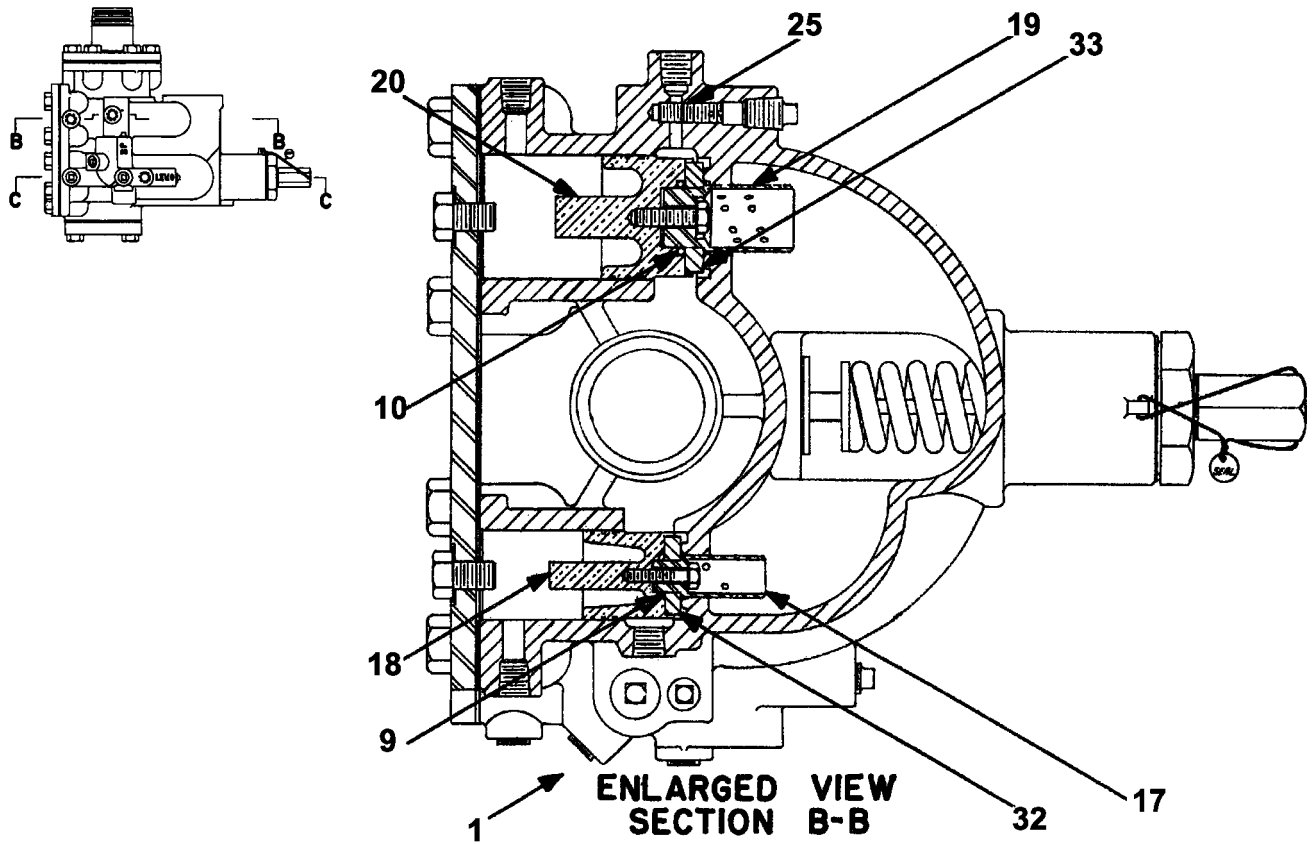

## 2" Manifold Valve

M.L. 2223B9, 2223B10, 2223B19 & 2223B23  
Order Form O-352C & O-352E

REF. No.	W/O VINTAGE PART No.	DESCRIPTION
1*	295B3	Ball, 5/8 in. Steel
9	182H4	Packing, "O" Ring, 9/16 in. I.D., 3/32 in. Thick, Rubber (for Piston Ref. 18)
10	182H1	Packing, "O" Ring, 1 in. I.D., 1/8 in. Thick, Rubber (for Piston Ref. 20)
17	◇	Piston (Metering Shell), Leveling Valve (for Piston Ref. 18)
18	442AE1	Piston, Leveling Valve
19	◇	Piston (Metering Shell), Lowering Valve (for Piston Ref. 20)
20	442P1	Piston, Lowering Valve
25	124BL1	Screw, Headless, 3/8 in. thread, 3/4 in. Long
32	129BL4	Washer, Valve Disc, 37/64 in. I.D., 1-13/32 in. O.D., 9/32 in. Thick, composition
33	129BL1	Washer, Valve Disc, 1-1/16 in. I.D., 2 in. O.D., 11/32 in. Thick, composition

\* Arrow indicates location. The part itself is not showing in the illustration.

◇ When ordering pistons (metering shells), give the elevator sales number and state for which valve the piston is required.

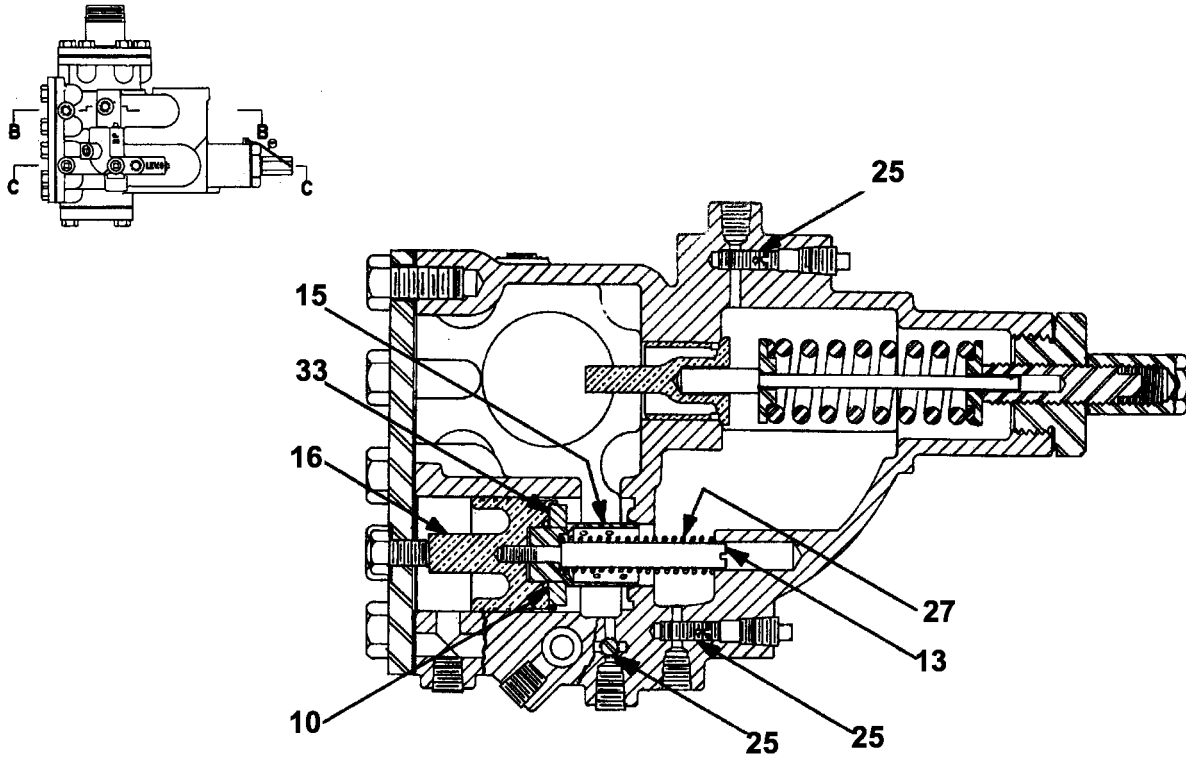
**C-1027****2223B "2" Manifold Valve****ENLARGED VIEW  
SECTION C-C****2" Manifold Valve**

M.L. 2223B9, 2223B10, 2223B19 & 2223B23  
Order Form O-352C & O-352E

<b>W/O VINTAGE</b>		
<b>REF. No.</b>	<b>PART No.</b>	<b>DESCRIPTION</b>
10	182H1	Packing, "O" Ring, 1 in. I.D., 1/8 in. Thick, Rubber (for Piston Ref. 16)
13	77NF3	Pin, By-pass Valve, 1/2 in. Diameter x 5-3/4 in. Long
	77NF2	Pin, By-pass Valve, 1/2 in. Diameter x 4-1/8 in. Long
15	◇	Piston (Metering Shell), By-Pass Valve (for Piston # Ref. 16)
16	442P1	Piston, By-Pass Valve
25	124BL1	Screw, Headless, 3/8 in. Thread, 3/4 in. Long
27	90XB3	Spring, Compression, 9/16 in. I.D., 4-5/8 in. Long, 20 Active Turns (for By-pass Valve)
	90XB6	Spring, Compression, 9/16 in. I.D., 4-3/4 in. Long, 15 Active Turns (for By-pass Valve)
33	129BL1	Washer, Valve Disc, 1-1/16 in. I.D., 2 in. O.D., 11/32 in. Thick, composition

◇ When ordering Pistons (Metering Shells), give the elevator sales number and state for which valve the piston is required.

# Pump

**C-1027**

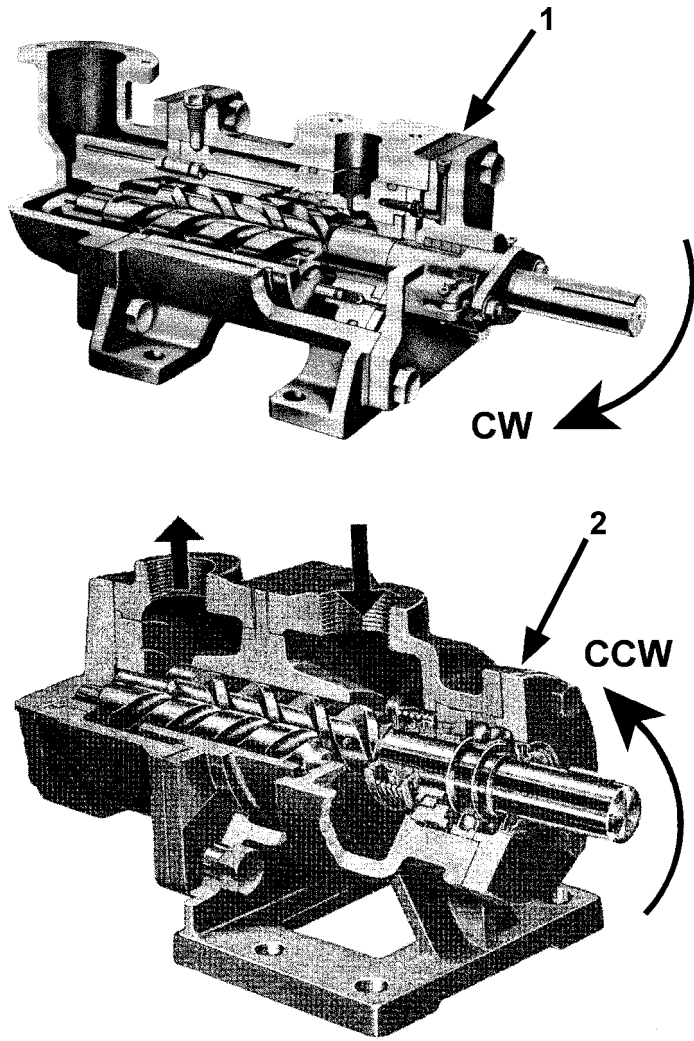

	<b>W/O VINTAGE</b>	
<b>REF. No.</b>	<b>PART No.</b>	<b>DESCRIPTION</b>
1	6962J2	Pump, DeLaval IMO, "D" Design (3DB-156), 46 G.P.M., 3600 R.P.M.
*	AAA27076AX2	Kit, Minor Repair, for IMO Pump, 3DB-156 (Ref. 1)
*	AAA27076AX3	Kit, Minor Repair, for IMO Pump, A3DB-156 (Ref. 1)
2	** ---	Pump, DeLaval IMO, Series A313B

**NOTE:** \* Part not shown.

\*\* When ordering, give elevator sales number.

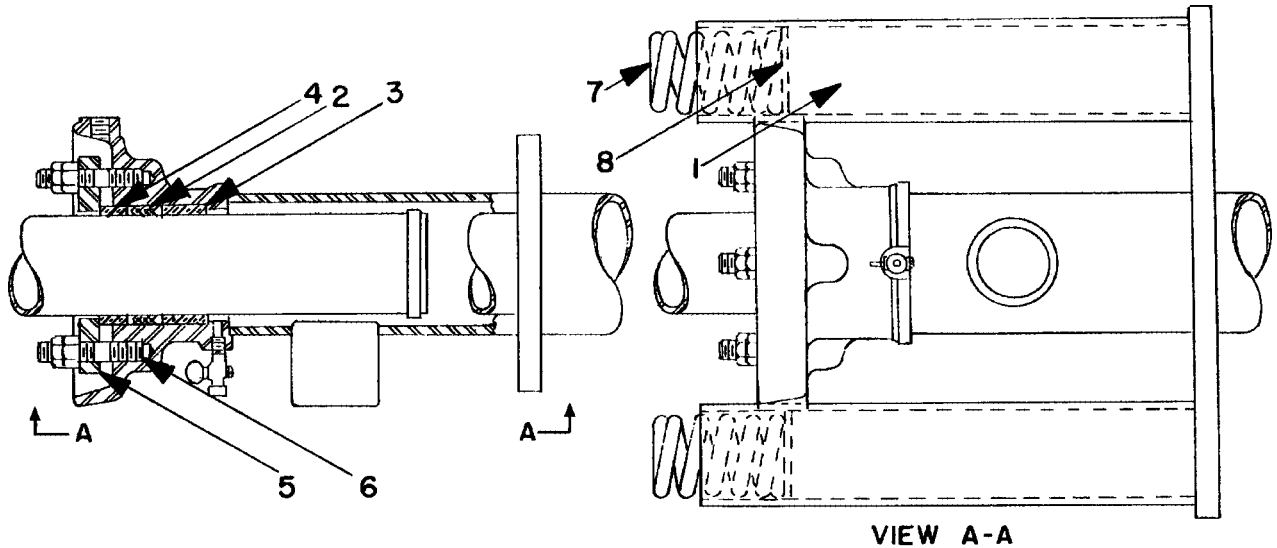
**C-1027****Cylinder Head Packing & Buffer**

ML 2223C-

W/O VINTAGE			
REF. No.	PART No.	DESCRIPTION	
1	310C10	Block	For Cylinder Head Packing Replacement Parts, See SPL: 03-6942Y
2	---182R_	Disogrin Packing	
3	---172GK_	Bottom Ring	
4	---172GK_	Top Ring	
5	---172GJ_	Clamp Ring	
6	---96H_	Rod	
7	90GD6	Spring	
8	127XA17	Washer	

# Type "F" Couplings

**C-1027**

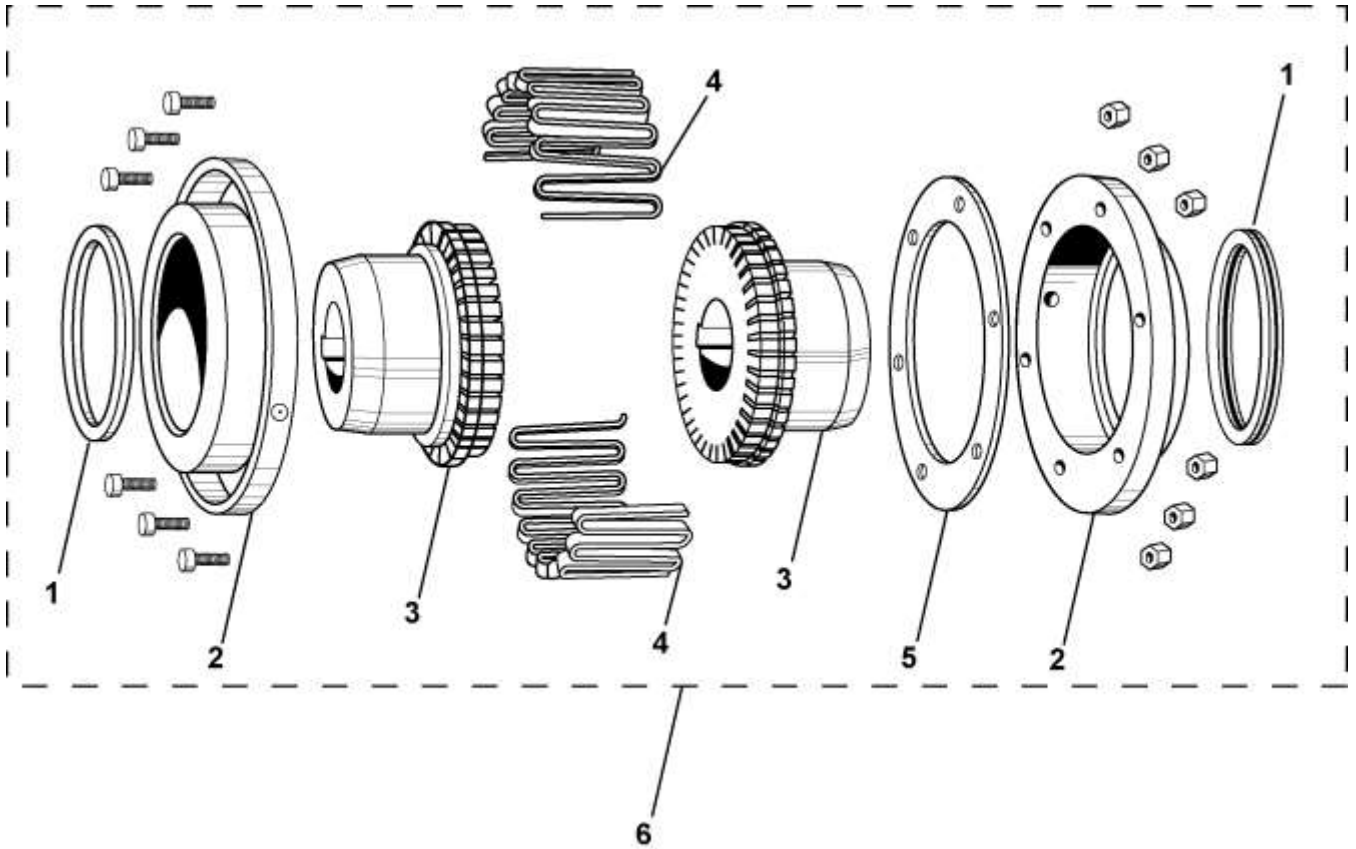

W/O VINTAGE		
REF. No.	PART No.	DESCRIPTION
1	---	Neoprene Seals
2	---	Cover Halves
3	---	Hubs
4	---	Gridmember
5	---	Gasket
6	215Y16	Type 5F, 4-1/2" dia., 1 in. bore pump-side, 1-1/8 in. bore motor-side (for 5, 7-1/2 HP motor)
	215Y17	Type 6F, 5 in. dia., 1 in. bore pump-side, 1-3/8 in. bore motor-side (for 10 HP motor)

**NOTE:** When ordering renewal parts, be sure to give the coupling size stamped on Cover and Coupling Hub. Also give the sales number, machine type, and motor HP.

**Isoline Unit & Hydraulic Muffler**

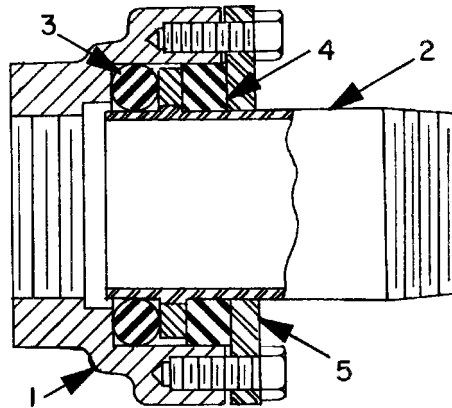

**Isoline Unit**

Part No.	Pipe Line Size (in.)	Ref. 1 Case	Ref. 2 Pipe	Ref. 3 Ring Pkg.	Ref. 4 Ring Pkg.	Ref. 5 Clamp Ring
6944A1	2	330CC1	377BE2	182F2	182G2	172GY1
6944A2	3	330CD1	377BE3	182F3	182G3	172GY2

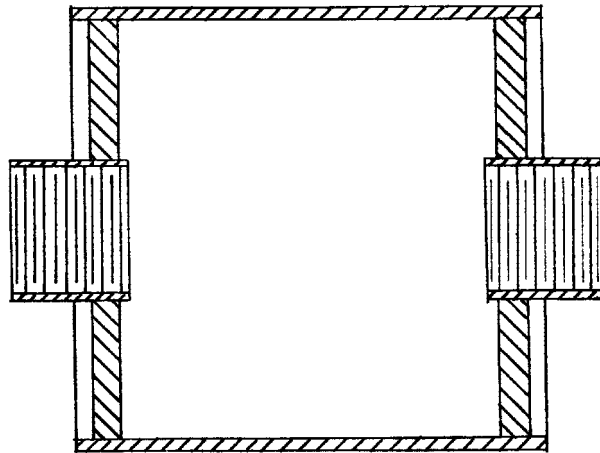

**Hydraulic Muffler**

12" O.D., 13" long, w/ Couplings  
Complete P/N 441AJ1