

Hydraulic Elevator with Type 13A Hydraulic Machine

Spare Parts Leaflet

C-1029

May 18, 2022 / Page 1 of 14

OBSOLESCENCE NOTICE

The product covered in this SPL has been designated as obsolete and is no longer supported. See TIP 32.2-1, *Obsolete Components*, for potential upgrade. Replacement lower level parts listed within and unique to this design are not being restocked when depleted. Some of these parts, depending on availability and other factors, may be quoted through Customer Service, but most will have extended lead times and increased cost due to low volume production.

New York Design

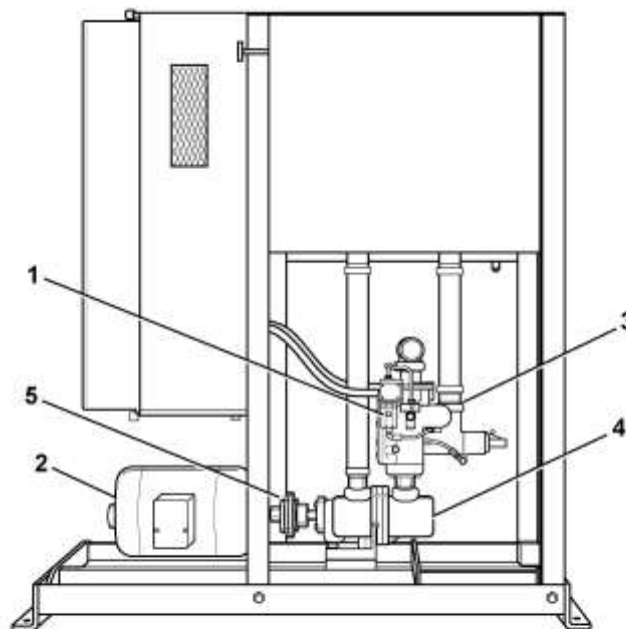

Typical Illustration

1. Pilot Valve	Page 4
2. Motor	Page 6
3. Manifold Valve	Pages 7, 8, 9, 10
4. Pump	Page 11
5. Coupling	Page 13

NOTE: For lubrication and hydraulic oil, see Lubrication Chart, Form #2422H.

Order Forms O-351A, O-352C, O-352E & O-352F

OTIS

This document does not contain any technical data subject to EAR or ITAR

SERVICE ENGINEERING
Otis Elevator Company
Bloomfield, Connecticut USA

Unpublished Work—© Otis Elevator Co.; 2022

Leaflet Description

This leaflet provides information for replacement parts for the New York Design hydraulic elevator, also known as plunger electric elevator, with type 13A machine, direct driven pump and manifold valve.

Leaflet Revisions

Date Revised	Subject Matter Expert	Reason for Revision
February 1, 1963	Works Service Dept., Yonkers, NY	New SPL
April 1, 1997	Technical Publications Dept., Otis Service Center	Update parts numbers
July 31, 2003	Troy Chicoine	Change pump part number, p. 11
September 14, 2007	Troy Chicoine	Corrected typos from 6962 to 6926.
May 18, 2022	Brian Regan	Updated document template and obsolescence info

Related Drawings

Drawing No.	Title	Drawing No.	Title
6926D1	---	6926E	Check Valve

Related Documents

Document ID	Title	Document ID	Title
Order Form O-351A	---	M.L. 2084E4	---
Order Form O-352E	---	M.L. 2223A22 through 25	---
Order Form O-352F	---	---	---

Subject Matter Expert

Name	Department
Brian Regan	OSC Service Engineering

About Spare Parts Leaflets...

This document lists the lowest replaceable units (LRUs) for the standard version of the product. The LRUs are chosen by a team of Otis associates representing engineering and manufacturing.

While goal of this document is to make parts identification as easy as possible, the document cannot be all-inclusive. Elevator and escalator contracts classified as "special" or "custom" are not addressed here. For such contracts, please refer to specified information, the contract folder, TIPs, Field Education Articles, Construction Letters, etc. for further information.

If you have any suggestions about this document, please contact the subject matter expert listed on this page.

Type 13A Hydraulic Machine

C-1029

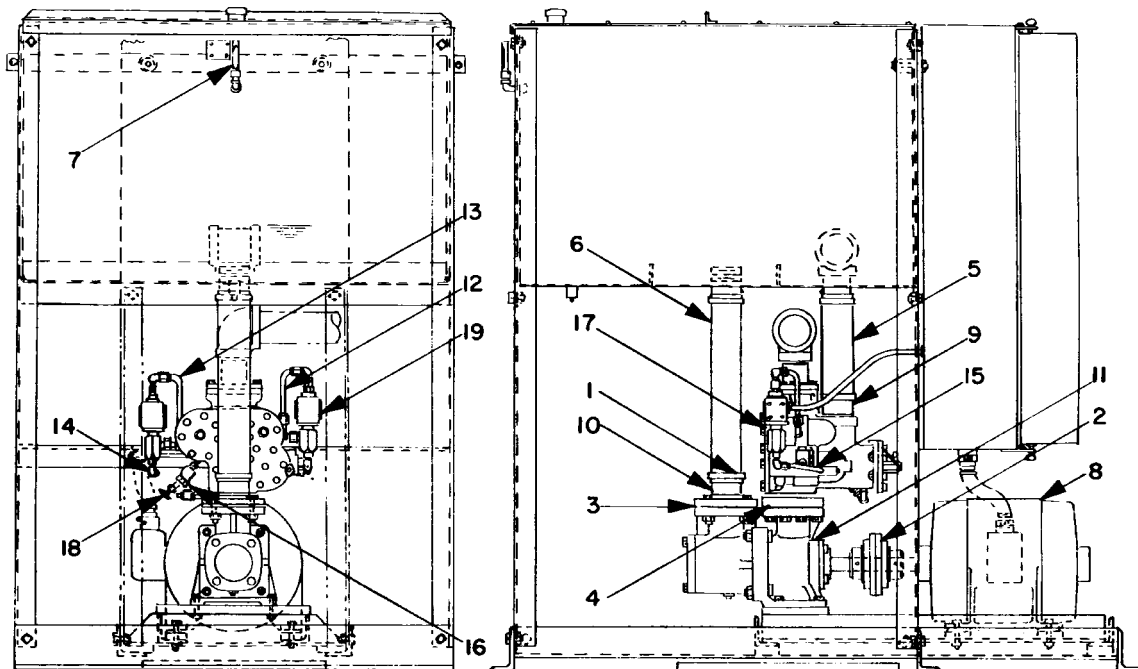

Order Form O-352F
ML 2084E4, 6926D1, 2, and 2223A22, 23, 24, 25

W/O VINTAGE		
REF. No.	PART No.	DESCRIPTION
*	254D1 B254D1	Bonnet, Oil Filter (for Oil Tank)
1	336DY1	Clamp, Hose
2	---	Coupling (for details, see Page 13)
3	376H7	Gasket, 2-7/8 in. id, 7 in. od, 1/16 in. Thick, Vellumoid (pump to tank)
4	376AA4	Gasket, 2-7/8 in. id, 5 in. square, 1/16 in. Thick, Vellumoid (pump to valve)
5	134A5	Hose, 3-1/2 in. id, 12-1/2 in. L (valve to tank)
6	134A11	Hose, 2-3/4 in. id, 23-1/4 in. L (pump to tank)
7	269AJ1 269AW1	Indicator, Oil
8	---	Motor, Single Speed (for details, see Page 6)
9	441AH10	Pipe, Half Nipple, 3 in. Std., 6 in. L (hose to valve)
10	441AH11	Pipe, Half Nipple, 2-1/2 in. Std., 6 in. L (hose to pump)
11	---	Pump (for details, see Page 11)
12	136AB2	Tubing, with Fittings
13	136AB4	Tubing, with Fittings
14	136AD2	Tubing, with Fittings
15	136AE2	Tubing, with Fittings
16	136AF2	Tubing, with Fittings
17	---	Valve, 2-1/2 in. Manifold (for details, see Pages 7 through 10)
18	---	Valve, Manual Lowering, Angle Screwed, 400# bronze
19	6941A1	Valve, Pilot (for details, see Page 4)

* Part not shown.

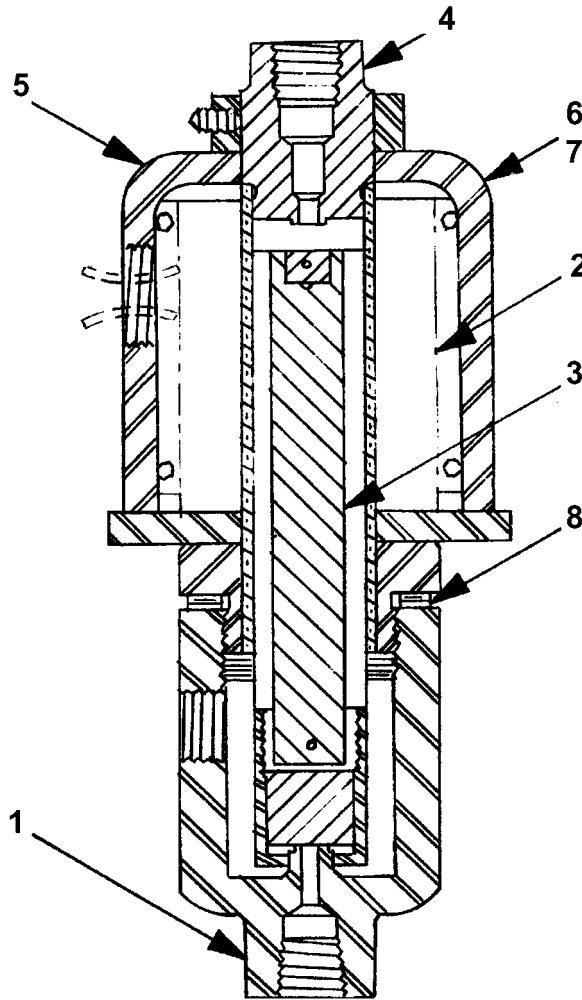

Pilot Valve
 for Leveling and Lowering Valves
 M.L. 6941A1

W/O VINTAGE		
REF. No.	PART No.	DESCRIPTION
1	330BF1	Case, Pilot Valve
2	222CV6	Coil, Magnet, 7300 Turns, No. 31 Wire
3	400BJ2	Core, Moveable
4	400BK1	Core, Stationary
5	374JG1	Frame, Magnet
6	386JR10	Plate, 2-3/8 in. Wide x 2-5/8 in. Long x 1/16 in. Thick
7	96H138	Rod, 1/8 in. Diameter, 3-1/4 in. Long (for Plates)
8	255CJ1	Shim, Laminum, (3) 0.003 in. Laminations, Brass

6926G Check Valve

C-1029

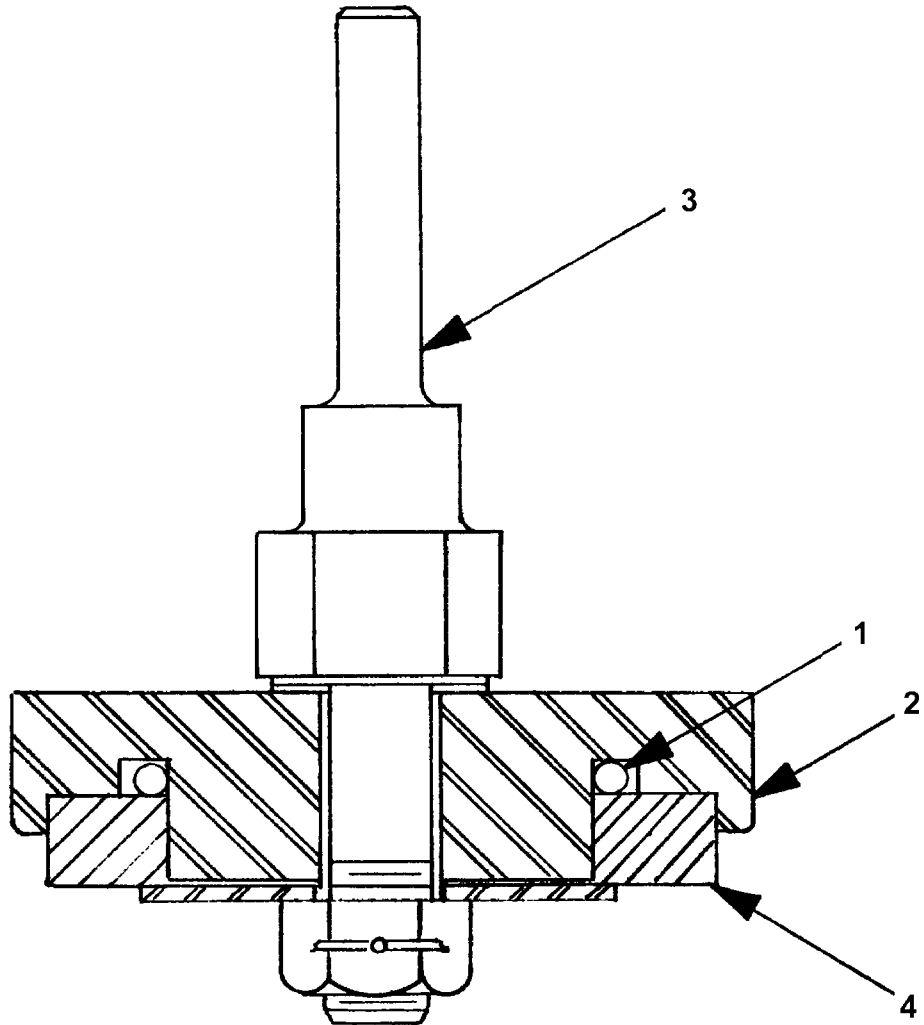

Check Valve
ML 6926G1

	W/O VINTAGE	
REF. No.	PART No.	DESCRIPTION
1	182H3	Packing, "O" Ring
2	445AT1	Plunger
3	95BP1	Rod, Shouldered
4	129BL3	Washer, Valve Disc

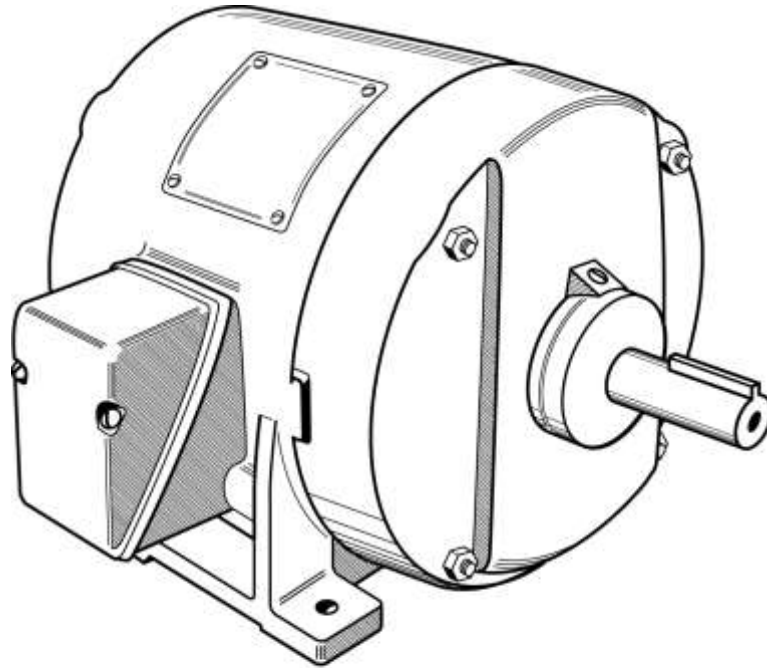
Single Speed Motors

Single Speed Motors
3 Phase, 60 Cycles, A.C., 3600 RPM

W/O VINTAGE

PART No.	VOLTS	NAME PLATE H.P.	FRAME No.
A6333Y1	208	20	284U
A6333Y2	220/440*	20	284U
A6333Y3	550	20	284U
A6333AA1	208	25	286U
A6333AA2	220/440*	25	286U
A6333AA3	550	25	286U
A6333AB1	208	30	324U
A6333AB2	220/440*	30	324U
A6333AB3	550	30	324U

* Specify voltage

2223B 2-1/2 Inch Manifold Valve

C-1029

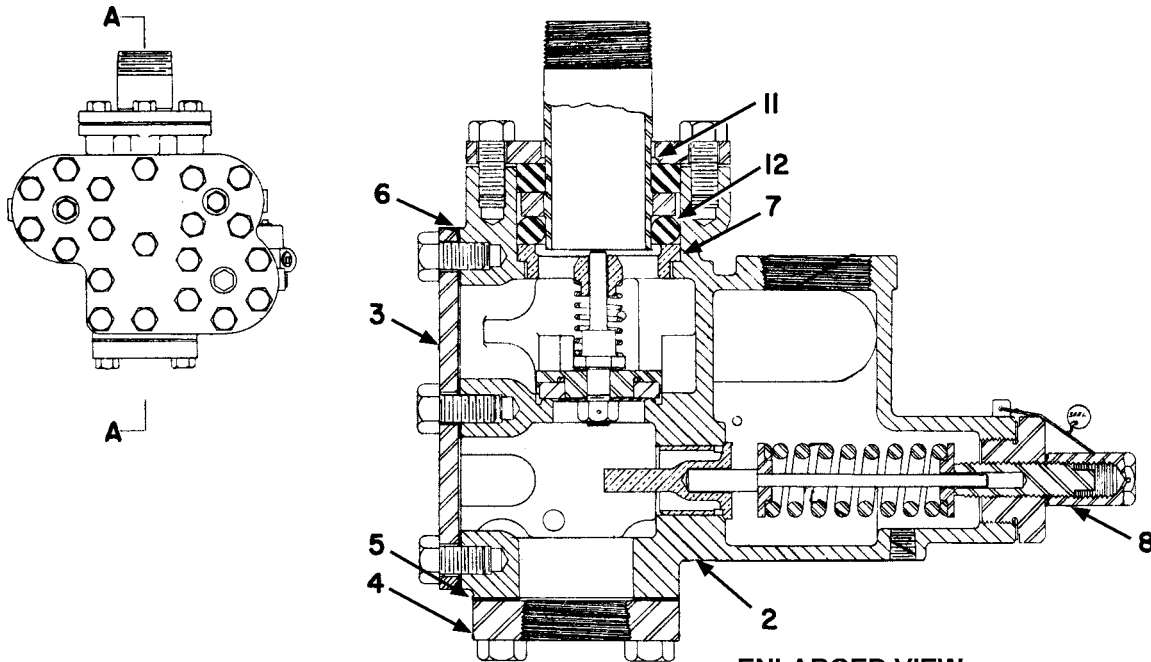

**ML 223B18 and 2223B22
Order Form O-352E**

W/O VINTAGE		
REF. No.	PART No.	DESCRIPTION
2	---	Case, Valve (If necessary to order, give elevator sales no. and size of manifold valve)
3	346WM1	Cover, Valve
4	346WL1	Cover
5	376CH1	Gasket, Vellumoid (for Cover Ref. # 4)
6	376CM1	Gasket, Vellumoid (for Cover Ref. # 3)
7	441AD1	Guide, Check Valve
8	72BY1	Nut, Cap, 1in. hex, 3/4 in. tap (for screw Ref. # 26)
11	182G1	Packing, Ring, 2-13/16 in. I.D., 4-5/16 in. O.D., 3/4 in. thick neoprene
12	182F1	Packing, Ring, 3/4 in. dia., 11 in. long (form at assembly)

(Continued on next page)

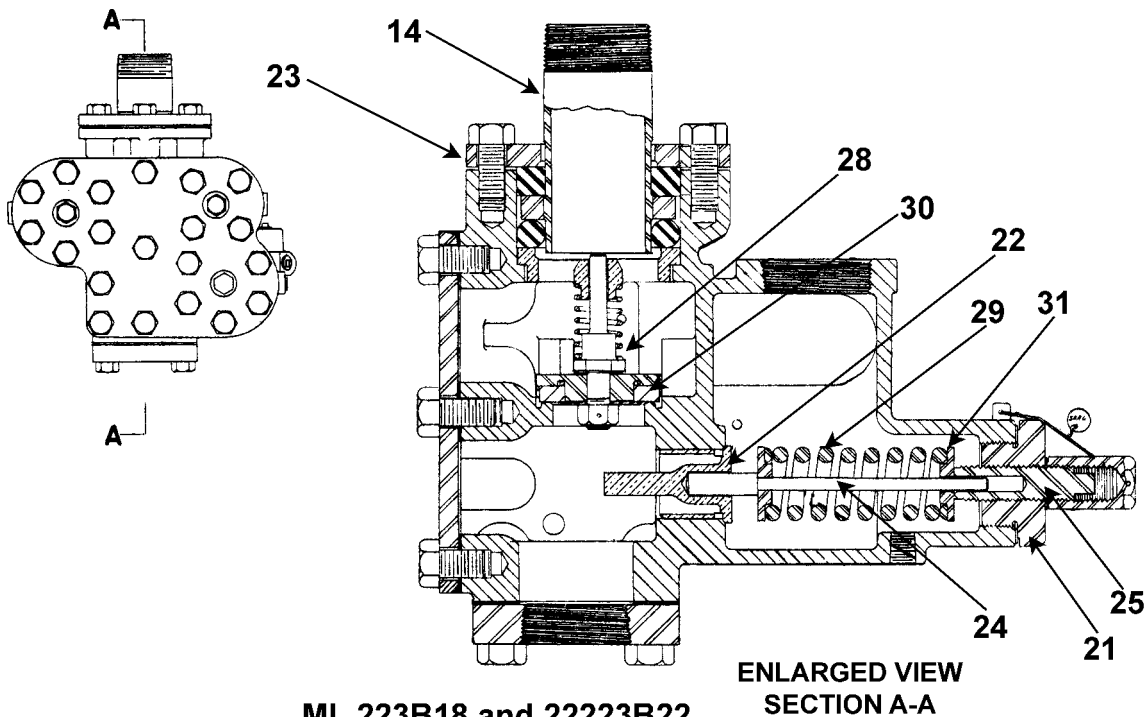

**ML 223B18 and 2223B22
Order Form O-352E**

W/O VINTAGE		
REF. No.	PART No.	DESCRIPTION
14	377BE1	Pipe, 2-1/2 in. std., 6 in. long
21	445AS1	Plunger, Relief Valve (for Rod Ref. # 23)
22	172GS1	Ring, Clamp (for Case)
23	96BE1	Rod, Relief Valve Piston, 3/8 in. dia., 8-9/32 in. long
24	96H137	Rod, 3/4 in. dia., 2-7/8 in. long
26	124BK1	Screw, 3/4 in. thread, 2-3/4 in. long (for Cover Ref. # 4)
28	90VB7	Spring, Check Valve, 27/32 in. I.D., 2-3/8 in. long, 5-3/4 active turns
29	90HD9	Spring, Relief Valve, 3-1/8 in. O.D., 6-1/8 in. long, 6 active turns
30	6926G1	Valve, Check (for details, see Page 5)
31	133G5	Washer, Spring Retaining

(Continued on next page)

2223B 2-1/2 Inch Manifold Valve

C-1029

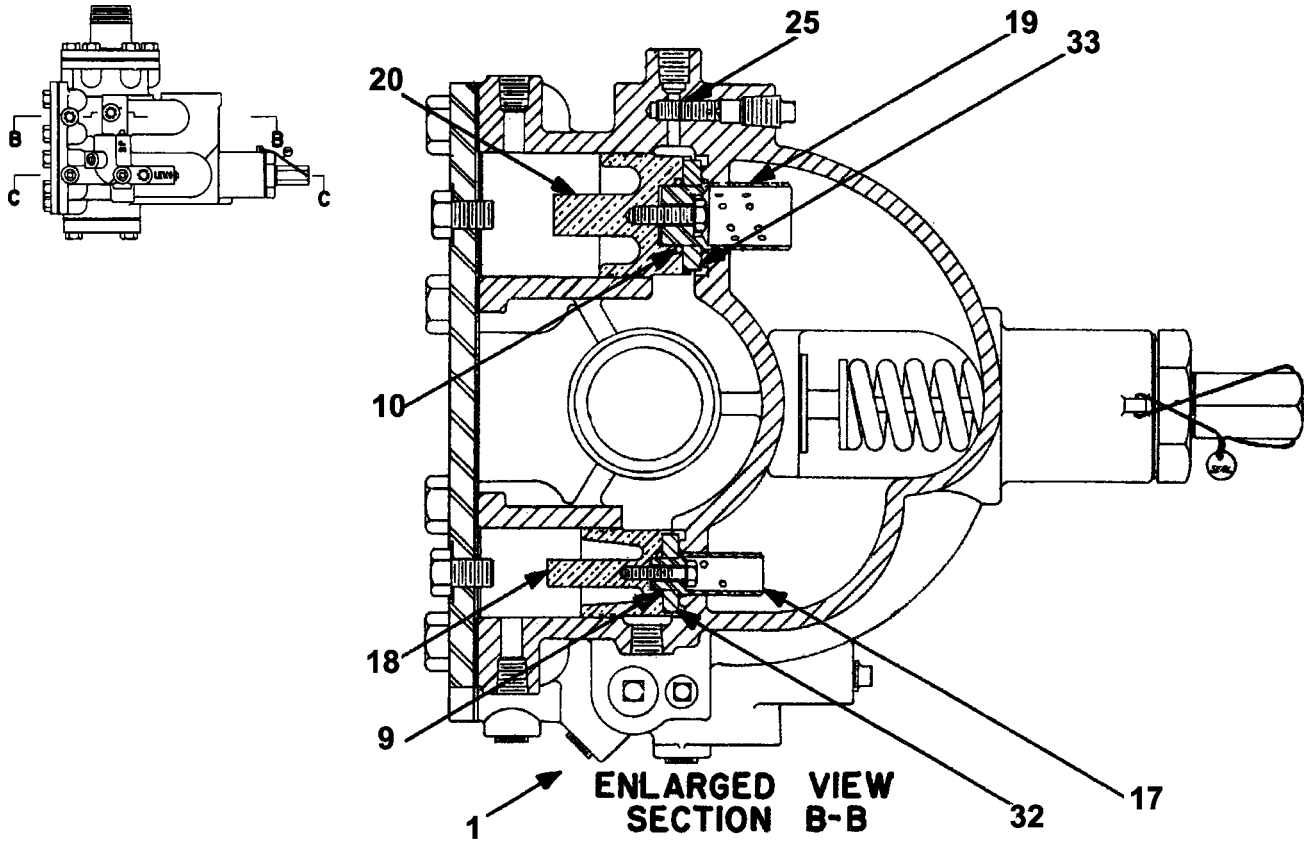

**ML 223B18 and 2223B22
Order Form O-352E**

W/O VINTAGE		
REF. No.	PART No.	DESCRIPTION
1*	295B3	Ball, 5/8 in. Steel
9	182H1	Packing, "O" Ring, 1 in. I.D., Rubber (for Piston Ref. 18)
10	182H2	Packing, "O" Ring, 1-7/16 in. I.D., Rubber (for Piston Ref. 16 & 20)
17	◇	Piston (Metering Shell), Leveling Valve (for Piston Ref. 18)
18	442P2	Piston, Leveling Valve
19	◇	Piston (Metering Shell), Lowering Valve (for Piston Ref. 20)
20	442W1	Piston, Lowering Valve
25	124BL1	Screw, Headless, 3/8 in. thread, 3/4 in. Long
32	129BL1	Washer, Valve Disc-1-1/16 in. I.D., 2 in. O.D., 11/32 in. Thick, composition
33	129BL2	Washer, Valve Disc, 1-1/2 in. I.D., 2-39/64 in. O.D., 3/8 in. Thick, composition

* Arrow indicates location. The part itself is not showing in the illustration.
 ◇ When ordering pistons (metering shells), give the elevator sales number and state for which valve the piston is required.

(Continued on next page)

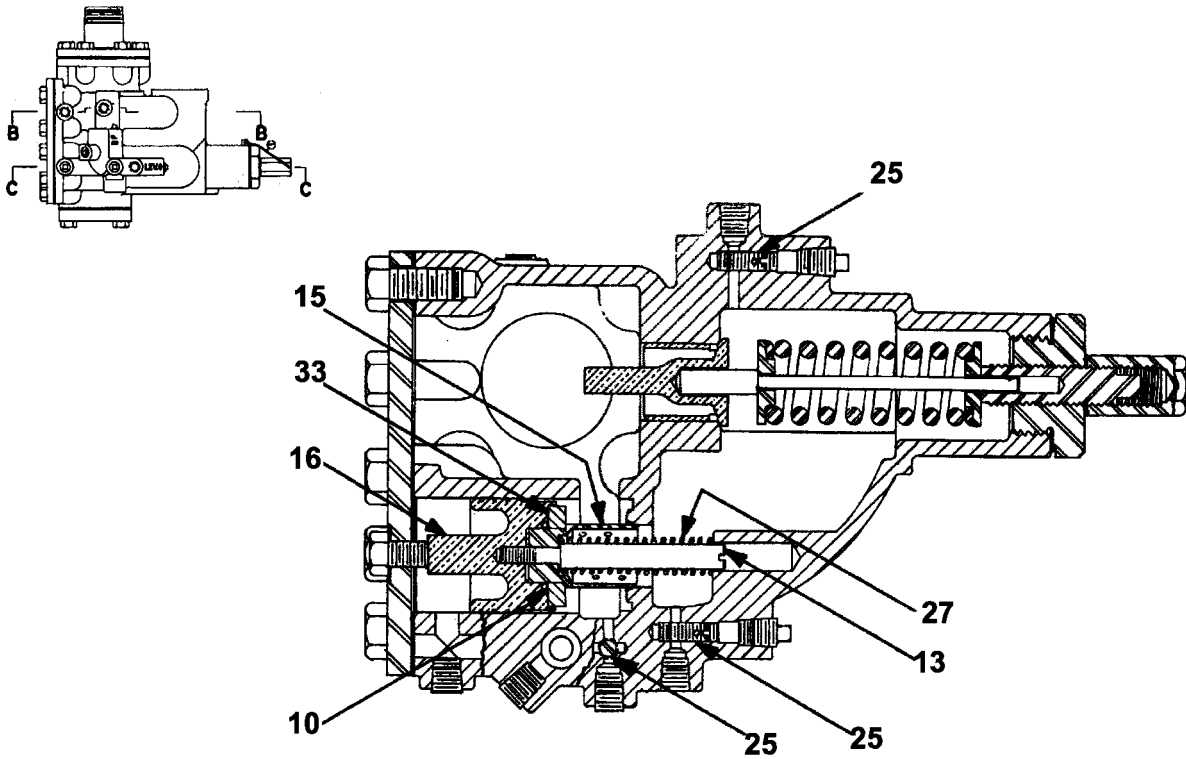
C-1029**2223B 2-1/2 Inch Manifold Valve**

**ENLARGED VIEW
SECTION C-C**

**ML 223B18 and 22223B22
Order Form O-352E**

W/O VINTAGE		
REF. No.	PART No.	DESCRIPTION
10	182H2	Packing, "O" Ring, 1-7/16 in. I.D., Rubber (for Piston Ref. 16 & 20)
13	77NF3	Pin, By-pass Valve, 1/2 in. Diameter x 5-3/4 in. Long
15	◇	Piston (Metering Shell), By-Pass Valve (for Piston # Ref. 16)
16	442W1	Piston, By-Pass Valve
25	124BL1	Screw, Headless, 3/8 in. Thread, 3/4 in. Long
27	90XB6	Spring, Compression, 9/16 in. I.D., 4-3/4 in. Long, 15 Active Turns (for By-pass Valve)
33	129BL2	Washer, Valve Disc, 1-1/2 in. I.D., 2-39/64 in. O.D., 3/8 in. Thick, composition

◇ When ordering Pistons (Metering Shells), give the elevator sales number and state for which valve the piston is required.

Pump

C-1029

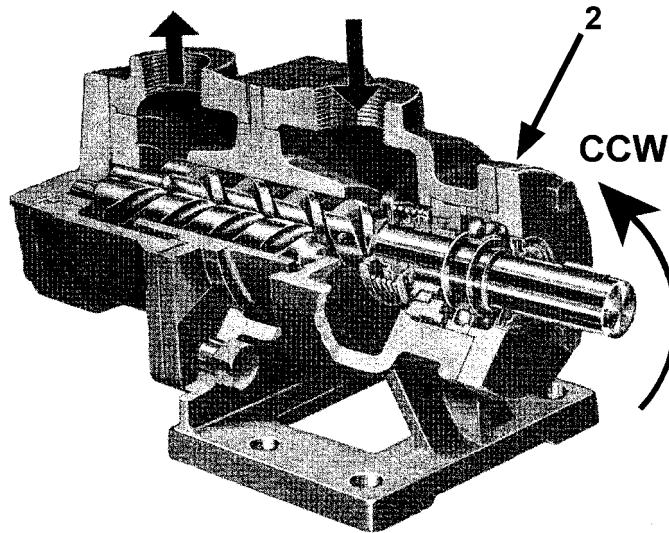
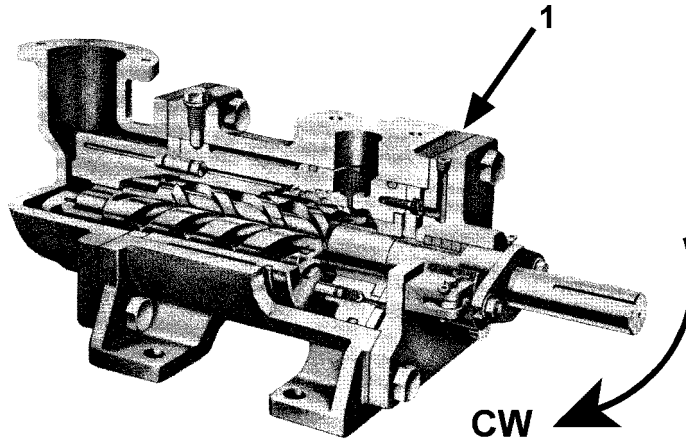

W/O VINTAGE		
REF. No.	PART No.	DESCRIPTION
1	A6926AW1	Pump, DeLaval IMO, "D" Design (3DB-218), 130 G.P.M., 3600 R.P.M.
*	AAA27076AX7	Kit, Minor Repair for IMO Pump, 3DB-218 (Ref. 1)
*	AAA27076AX8	Kit, Minor Repair for IMO Pump, A3DB-218 (Ref. 1)
*	AAA27076AX9	Kit, Minor Repair for IMO Pump, G3DB-218 (Ref. 1)
2	** - - -	Assembly, DeLaval IMO Pump, Series A313B

NOTE: * Part not shown.

** When ordering, give elevator sales number.

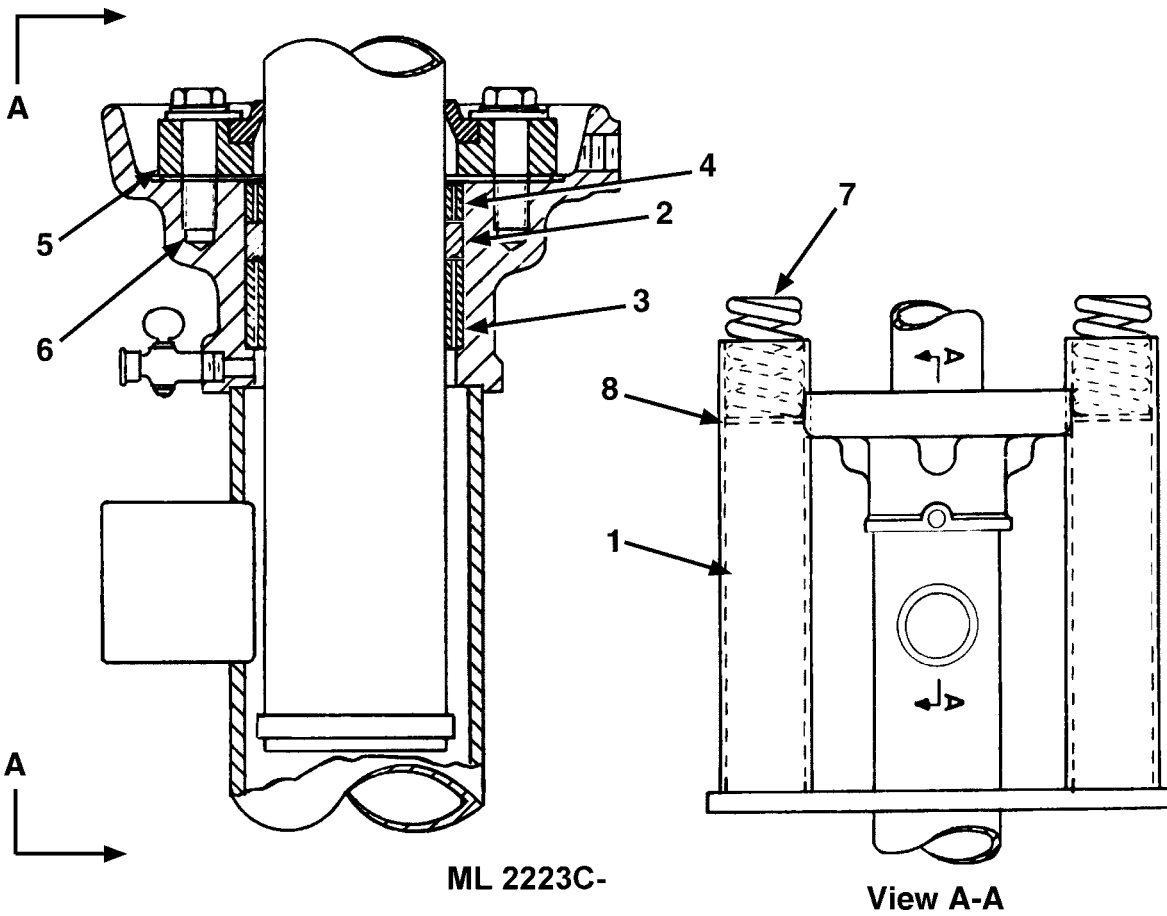

W/O VINTAGE			
REF. No.	PART No.	DESCRIPTION	
1	310C10	Block	
2	---182R_	Disogrin Packing	
3	---172GK_	Bottom Ring	
4	---172GK_	Top Ring	
5	---172GJ_	Clamp Ring	
6	---96H_	Rod	
7	90GD6	Spring	
8	127XA17	Washer	

**For Cylinder Head Packing Replacement Parts,
See SPL 03-6942Y.**

Type "F" Couplings

C-1029

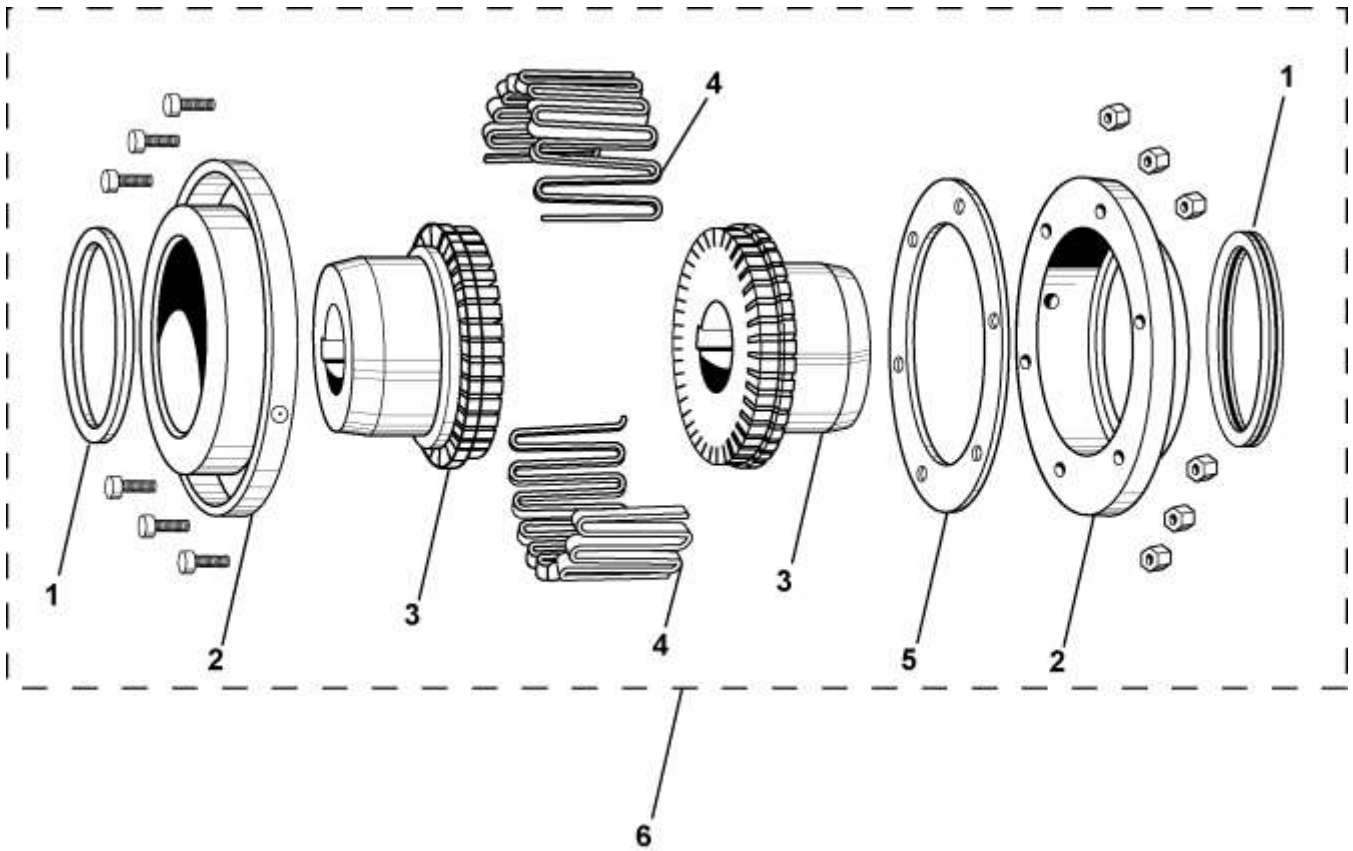

		W/O VINTAGE
REF. No.	PART No.	DESCRIPTION
1	---	Neoprene seals
2	---	Cover Halves
3	---	Hubs
4	---	Gridmember
5	---	Gasket
6	215Y2	Type 7F, 5-5/8 in. Dia., 1-1/2 in. Bore-Pump Side, 1-5/8 in. Bore-Motor Side (for 20 or 25 HP motors)
	215Y8	Type 8F, 7-1/8 in. Dia., 1-1/2 in. Bore-Pump Side, 1-7/8 in. Bore-Motor Side (for 30 HP motor)

Note: When ordering renewal parts, be sure to give the coupling size stamped on Cover and Coupling Hub. Also give the sales number, machine type, and motor HP.

C-1029

Isoline Unit & Hydraulic Muffler

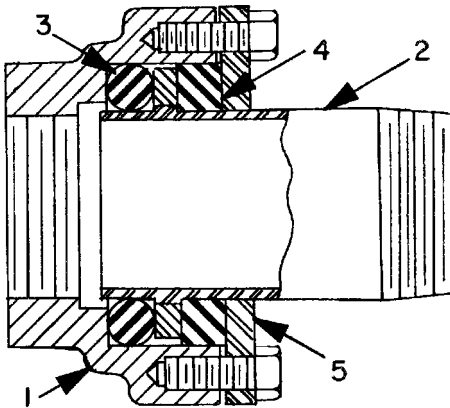

Isoline Unit

Part No.	Pipe Line Size (in.)	Ref. 1 Case	Ref. 2 Pipe	Ref. 3 Ring Pkg.	Ref. 4 Ring Pkg.	Ref. 5 Clamp Ring
6944A1	2	330CC1	377BE2	182F2	182G2	172GY1
6944A2	3	330CD1	377BE3	182F3	182G3	172GY2

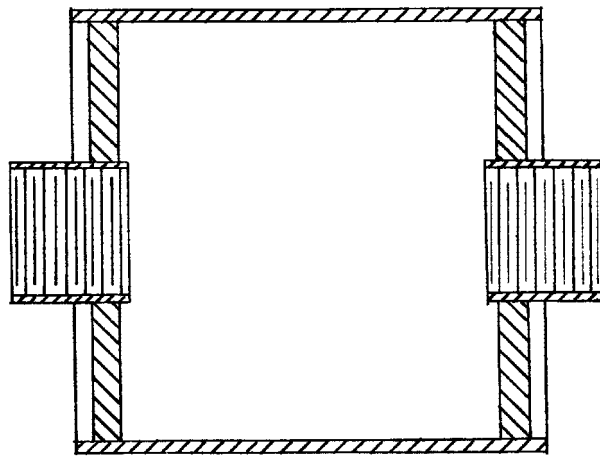

Hydraulic Muffler

12" O.D., 13" long, w/ Couplings
Complete P/N 441AJ1