

**Hydraulic Elevator with
Type
5B Hydraulic Machine**

Spare Parts Leaflet

C-1049

May 18, 2022 / Page 1 of 11

OBSOLESCENCE NOTICE

The product covered in this SPL has been designated as obsolete and is no longer supported. See TIP 32.2-1, *Obsolete Components*, for potential upgrade. Replacement lower level parts listed within and unique to this design are not being restocked when depleted. Some of these parts, depending on availability and other factors, may be quoted through Customer Service, but most will have extended lead times and increased cost due to low volume production.

New York Design

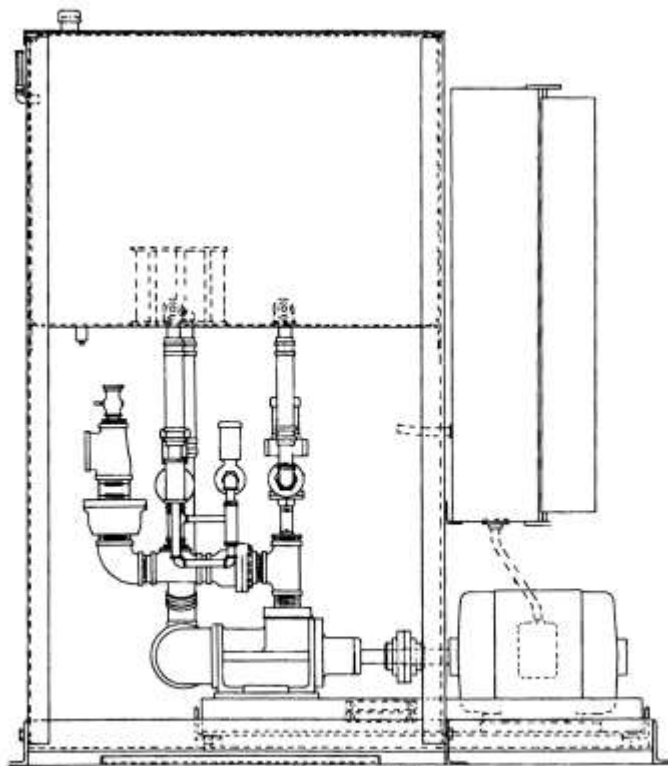

Typical Illustration

NOTE: For Lubrication and Hydraulic Oil, see Lubrication Chart Form #2422H.
Order Form: O-352G

OTIS

This document does not contain any
technical data subject to EAR or ITAR

SERVICE ENGINEERING
Otis Elevator Company
Bloomfield, Connecticut USA

Unpublished Work—© Otis Elevator Co.; 2022

Leaflet Description

This leaflet provides information for replacement parts for the New York Design hydraulic elevator, also known as plunger electric elevator, with type 5B machine, direct driven pump and EECO valves.

Leaflet Revisions

Date Revised	Subject Matter Expert	Reason for Revision
May 16, 1966	Works Service Dept., Yonkers, NY	New SPL
April 1, 1997	Technical Publications Dept., Otis Service Center	Update parts numbers
July 31, 2003	Troy Chicoine	Change pump part number, p. 11
May 18, 2022	Brian Regan	Updated document template and obsolescence info

Related Drawings

Drawing No.	Title	Drawing No.	Title
6962D1	---	6962E	Check Valve

Related Documents

Document ID	Title	Document ID	Title
Order Form O-352G	---	M.L. 2084E4	---
Order Form O-352E	---	M.L. 2084E6	---
Order Form O-352F	---	M.L. 2223A22 through 25	---
---	---	M.L. 2223F2	---

Subject Matter Expert

Name	Department
Brian Regan	OSC Service Engineering

About Spare Parts Leaflets...

This document lists the lowest replaceable units (LRUs) for the standard version of the product. The LRUs are chosen by a team of Otis associates representing engineering and manufacturing.

While goal of this document is to make parts identification as easy as possible, the document cannot be all-inclusive. Elevator and escalator contracts classified as "special" or "custom" are not addressed here. For such contracts, please refer to specified information, the contract folder, TIPS, Field Education Articles, Construction Letters, etc. for further information.

If you have any suggestions about this document, please contact the subject matter expert listed on this page.

Type 5B Hydraulic Machine

C-1049

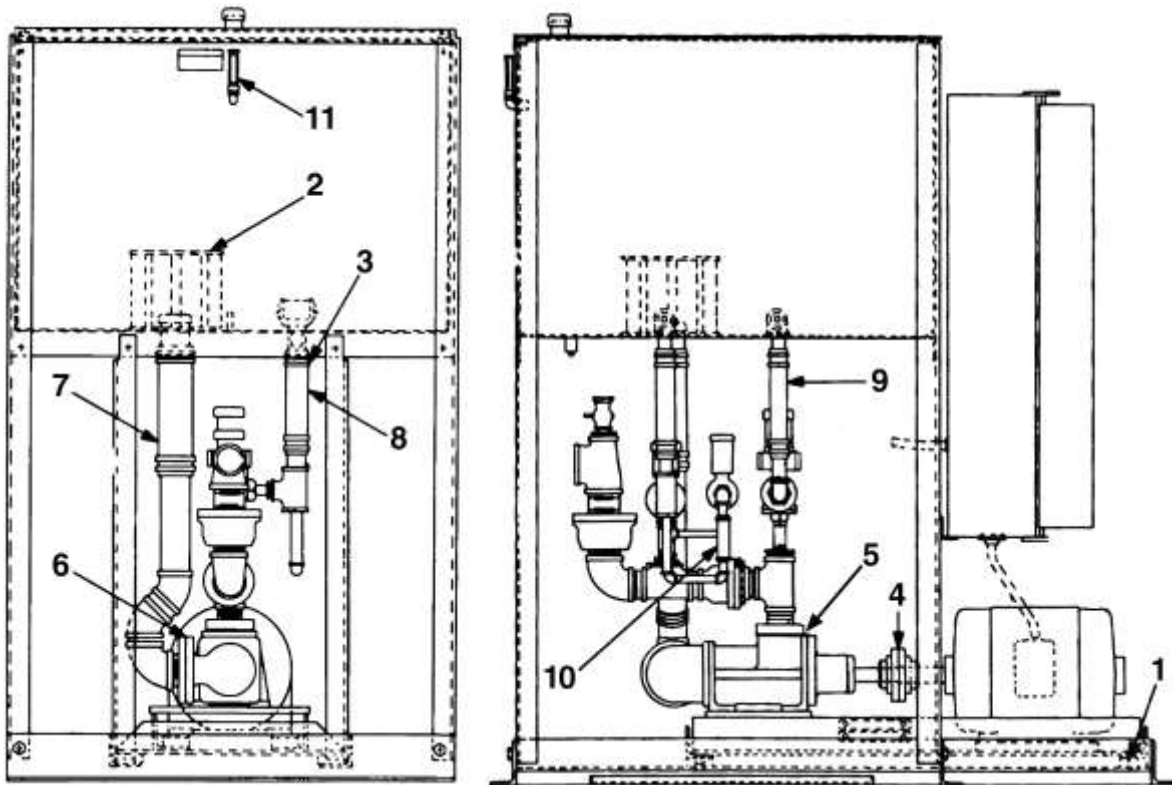

W/O VINTAGE

REF. No.	PART No.	DESCRIPTION
1	310BE3	Block, rubber, 3 inch wide, 3 inch long, 1 inch thick
2	254D4	Bonnet, Oil Filter (for Oil tank)
	B254D1	
3	336DY1	Clamp, Hose
---	6926AE1	Clamp, Hose Shut-off (Not illustrated, stored in bedplate when not in use.)
4	---	Coupling (for details, see Page 10)
5	---	See NOTE
6	---	See NOTE
7	134A10	Hose, 2-1/4inch I.D., 17-3/4inch long (for Tank to Pump)
8	134A14	Hose, 1-5/8 inch I.D., 15 inch long (for tank to valve)
9	134A13	Hose, 1 inch I.D., 15 inch long (for tank to valve)
10	134A21	Hose, 1 inch I.D., 5 inch long (for tank to valve)
11	269AW1	Indicator, Oil

NOTE: For 5B Machine, piping from tank to pump will be straight. Also, reference numbers 5 and 6 are gaskets not required for this machine.

(Continued on next page)

Type 5B Hydraulic Machine

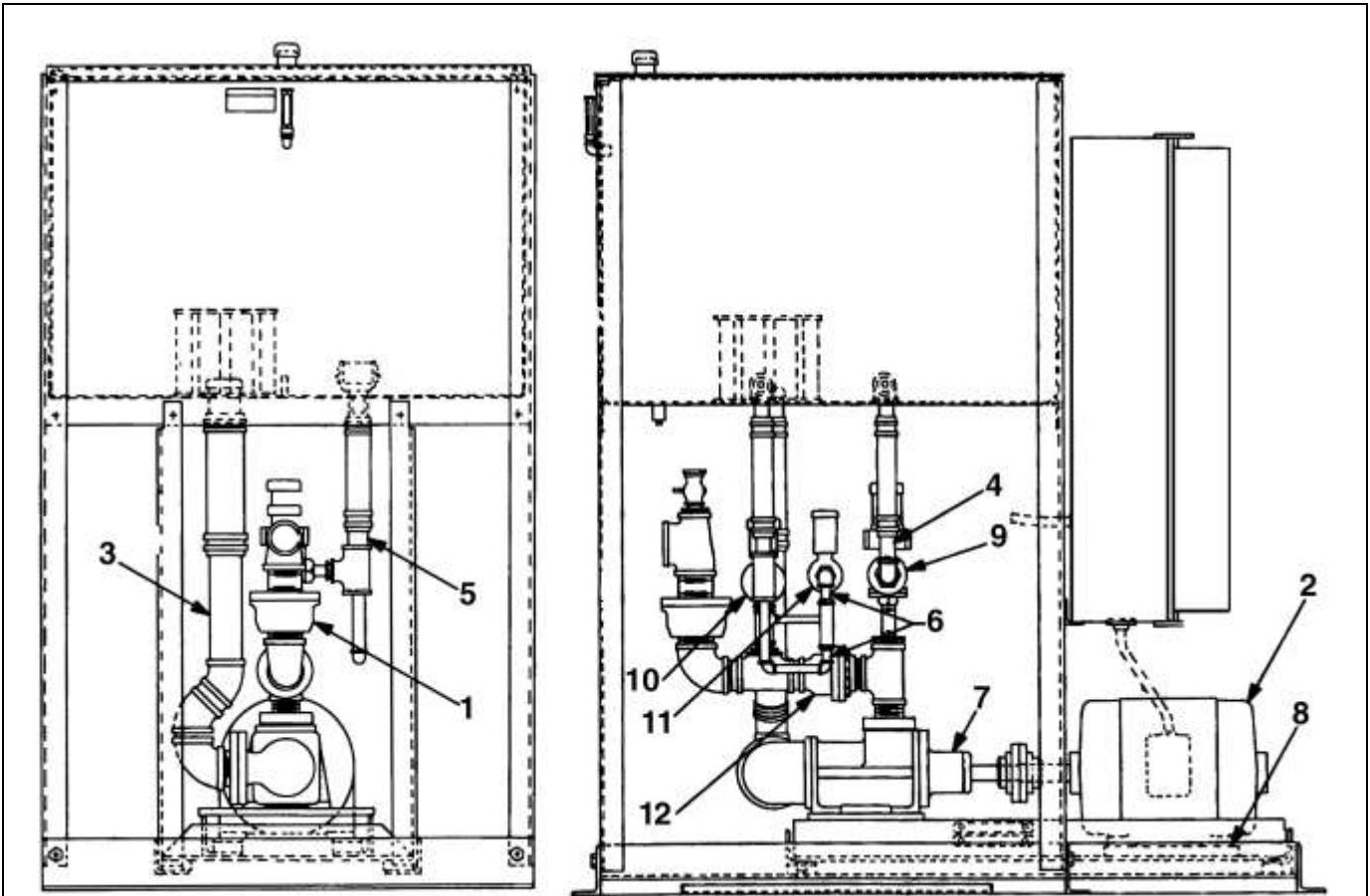

W/O VINTAGE

REF. No.	PART No.	DESCRIPTION
1	6944A1	Isoline, Pipe Line Silencer (for details, see Page 10)
2	---	Motor (for details, see Page 6)
3	441AH8	Pipe, Half Nipple, 2 inch std., 16-5/8 inch long (for Hose p/n 134A10)
4	441AH14	Pipe, Half Nipple, 3/4 inch std., 6 inch long (for hose p/n 134A13)
5	441AH17	Pipe, Half Nipple, 1-1/4 inch std., 4 inch long (for Hose p/n 134A14)
6	441AH23	Pipe, Half Nipple, 3/4 inch std., 2 inch long (for Hose p/n 134A21)
7	6962J1	Pump (for details, see Page 7)
8	255AB24	Shim, steel, 2 inch wide, 2 inch long, .0598 inch thick (for Motor)
	255AB25	Shim, steel, 2 inch wide, 2 inch long, .0299 inch thick (for Motor)
9	---	Valve, By-pass (used when Up Leveling is not required) (see page 5)
	---	Valve, Up Leveling (for details, see Page 5)
10	---	Valve, Down (for details, see Page 8)
11	---	Valve, Down Leveling (for details, see Page 8)
12	271W2	Valve, Check (for details, see Page 7)

By-Pass & Up Leveling Valves

C-1049



By-Pass Valve
EECO Type BP-3

W/O VINTAGE		
PART No.	DESCRIPTION	VALVE SIZE
271J2	Valve, Bypass	3/4

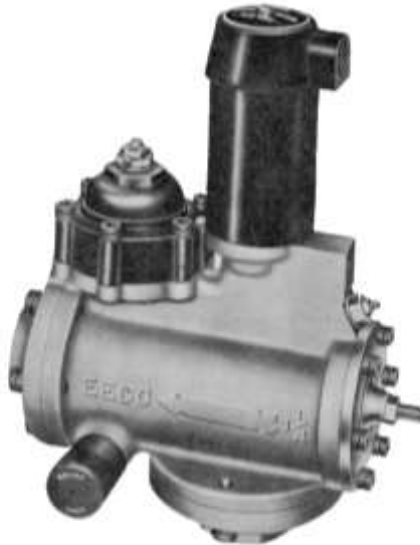

Up Leveling Valve
EECO Type UV-2

W/O VINTAGE		
PART No.	DESCRIPTION	VALVE SIZE
271P2	For replacement of EECO Type UV-2 valve, refer to TIP 6.3.0-12	3/4

Single Speed Motors

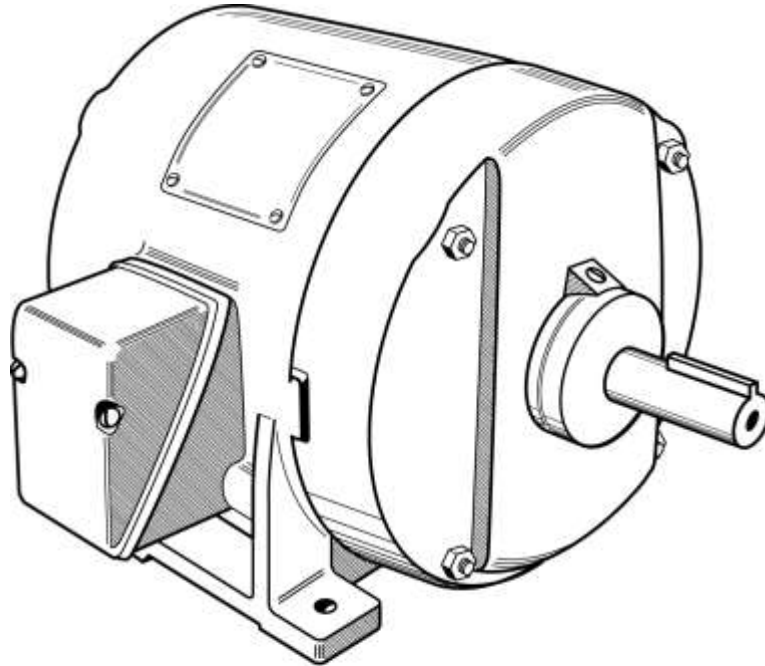

Single Speed Motors
3 Phase, 60 Cycles, A.C., 3600 RPM

W/O VINTAGE			
REF. No.	PART No.	Name Plate H.P.	Frame No.
A6333BV1	208	5	213
A6333P2	220/440*	5	213
A6333P3	550	5	213
A6333R1	208	7-1/2	215
A6333R2	220/440*	7-1/2	215
A6333R3	550	7-1/2	215
A6333T1	208	10	254U
A6333T2	220/440*	10	254U
A6333T3	550	10	254U

* Specify voltage

Check Valve & Pump

C-1049



Check Valve
EECO Series 3000

W/O VINTAGE		
PART No.	DESCRIPTION	VALVE SIZE
271W2	Check Valve	1-1/2

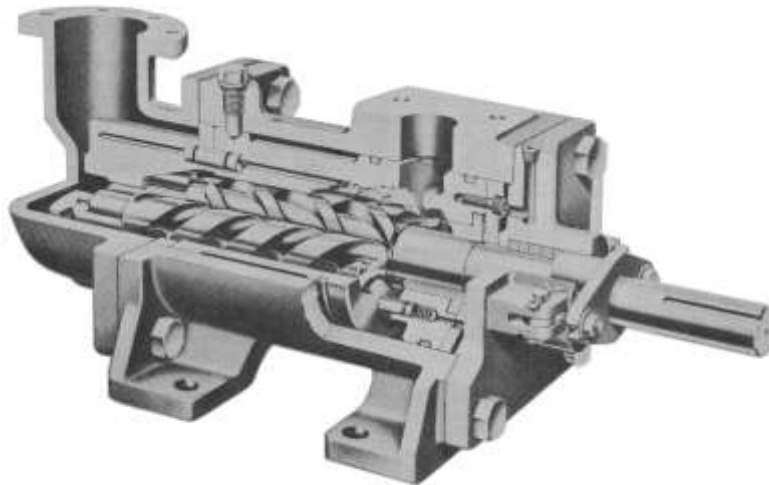

De Laval Imo Pump

W/O VINTAGE		
PART No.	DESCRIPTION	
6962J2	Pump, Type 156, 46 GPM, at 3600 RPM	
AAA27076AX2	Minor Repair Kit (for pump model 3DB-156)	
AAA27076AX3	Minor Repair Kit (for pump model A3DB-156)	

DL-3 Down & Down Leveling Valves



W/O VINTAGE

Down Valve

New - EECO Type DL-3		Replaces - EECO Type DL-2	
PART NO.	VALVE SIZE	PART NO.	VALVE SIZE
* 271BA3	1/2	271T5	1/2
		271T6	
* 271BA4	3/4	271T7	3/4
		271T8	

Down Leveling Valve

New - EECO Type DL-3		Replaces - EECO Type DL-2	
PART NO.	VALVE SIZE	PART NO.	VALVE SIZE
271BA1	1/4	271T1	1/4
		271T2	
271BA2	3/8	271T3	3/8
		271T4	
* 271BA3	1/2	271T5	1/2

NOTES: 1. The DL-3 valve is identical to the DL-2 valve with an additional throttle.

*2. Refer to TIP 6.3.0-12 for replacement of these EECO type DL-3 valves.

Cylinder Head Packing & Buffer Data

C-1049

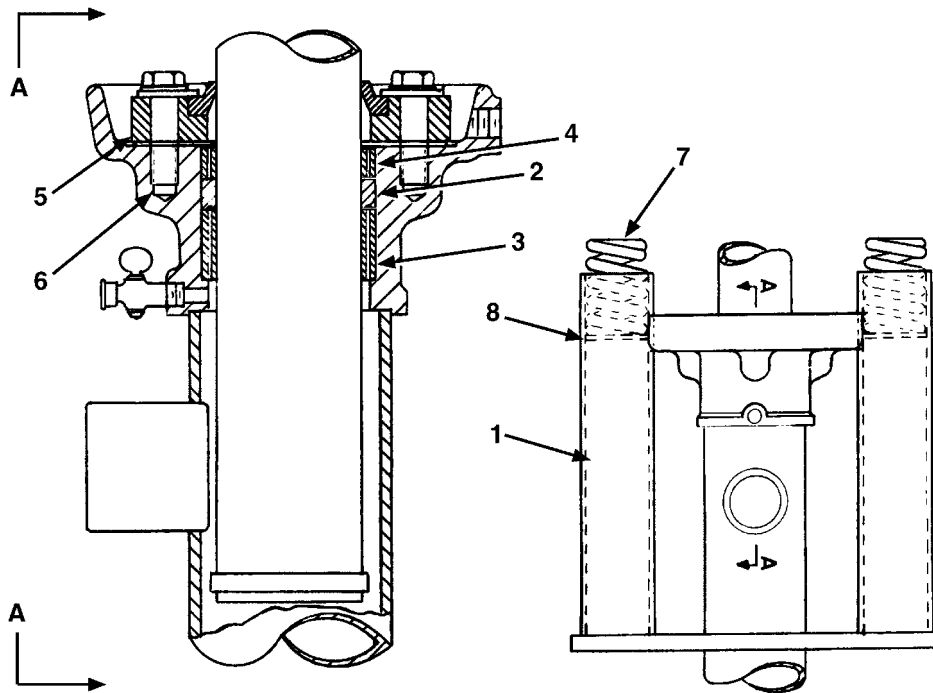

ML 2223C-
DWG 6942AA, 6942Y

View A-A

W/O VINTAGE

Cylinder Size (inch)	Plunger (inch)	Ref. 1 Part No. Block 2-Req'd	Ref. 2 Part No. Disogrin Packing 1-Req'd	Ref. 3 Part No. Bottom Ring 1-Req'd	Ref. 4 Part No. Top Ring 1-Req'd	Ref. 5 Part No. Clamp Ring 1-Req'd	Ref. 6 Part No. Rod *- Req'd	Ref. 7 Part No. Spring 2-Req'd	Ref. 8 Part No. Washer 2-Req'd	Ref. 9 Part No. Wiper Clamp Ring 1-Req'd	Ref. 10 Part No. Spring *-Req'd	Ref. 11 Part No. Washer *-Req'd
5	4	310C11 ▲ 310C12 ▲	376NG1	A390AMI	182R1	172LL1	172KN1	172KP1	172LG1	172LK1	90KD8 ▲ 90ND5 ▲	127VD14
6	4-1/2	310C11 ▲ 310C12 ▲	376NG2	A390ANI	182R2	172LL2	172KN2	172KP2	172LG2	172LK2	90KD8 ▲ 90ND5 ▲	127VD14
8	5-1/2	310C13	376NG3	A390API	182R3	172LL3	172KN3	172KP3	172LG3	172LK3	90ND5 ▲ 90TD4 ▲	127VD15
8	6-1/2	310C14	376NG4	A390ARI	182R4	172LL4	172KN4	172KP4	172LG4	172LK4	90TD4 ▲ 90AL2 ▲	127XA10
10	7-1/2	310C15	376NG5	A390ASI	182R5	172LL5	172KN5	172KP5	172LG5	172LK5	90AL2 ▲ 90ZD3 ▲	127VE8
10	8-1/2	310C15	376NG6	A390ATI	182R6	172LL6	172KN6	172KP6	172LG6	172LK6	90AL2 ▲ 90ZD3 ▲	127VE8
12	9-1/2	310C14	376NG7	A390AVI	182R7	172LL7	172KN7	172KP7	172LG7	172LK7	90TD4 ▲ 90AL2 ▲	127XA10
12	10-1/2	310C15	376NG8	A390AWI	182R8	172LL8	172KN8	172KP8	172LG8	172LK8	90AL2 ▲ 90ZD3 ▲	127VE8
16	12-1/2	310C15	376NG9	A390AXI	182R9	172LL9	172KN9	172KP9	172LG9	172LK9	90ZD3 ▲	127VE8

**FOR CYLINDER HEAD PACKING
REPLACEMENT PARTS
SEE SPARE PARTS LEAFLET**

03-6942Y

* Quantity variable.

▲ Gross load determines part to use. For replacement, give elevator sales number.

Couplings

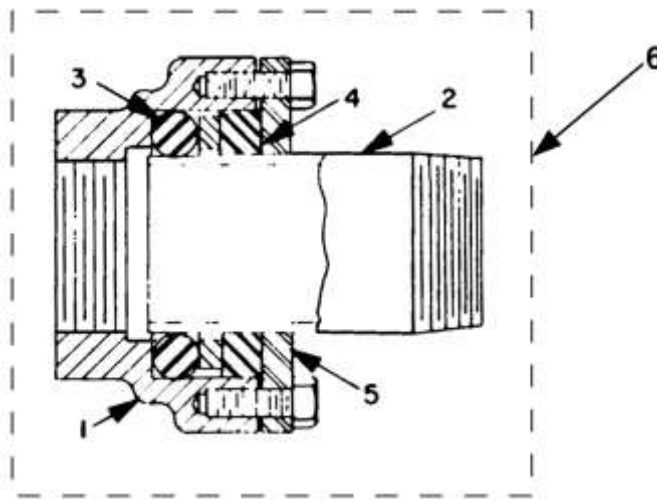

W/O VINTAGE

REF. No.	PART No.	DESCRIPTION
1	330CC1	Case, Ductile Iron
2	377BE2	Pipe, 2" Std., Steel
3	182F2	Ring, Packing, Neoprene
4	182G2	Ring, Packing, Neoprene
5	172GY1	Ring, Clamp, Steel
6	6944A1	Isoline, Complete

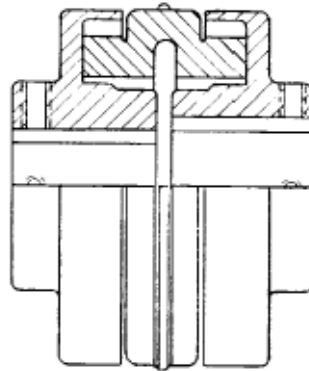

Couplings

W/O VINTAGE

PART No.	O.D. (inch)	Bore Pump Side (inch)	Bore Motor Side (inch)	Used With
215AR2	3-1/4	1	1-1/8	5 H.P. Motor
215AR3	4			7-1/2 H.P. Motor
215AR4			7/8	10 H.P. Motor

Hydraulic Muffler

C-1049

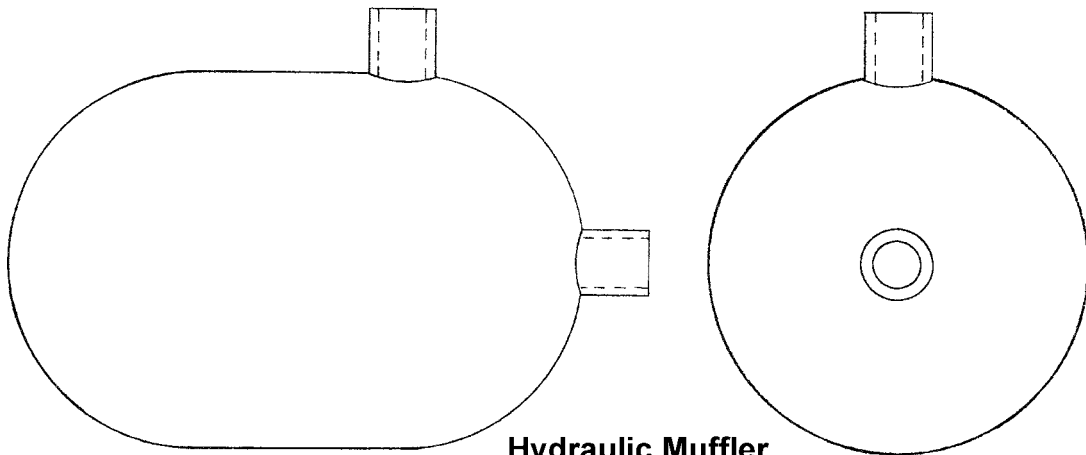

Hydraulic Muffler
8-5/8" O.D., with Couplings
Part No. 441AM1