

# Type 6379P Inductor Switch

## Spare Parts Leaflet C-1069

October 20, 2006 / Page 1 of 2

Supersedes C-1069 Dated October 15, 1968

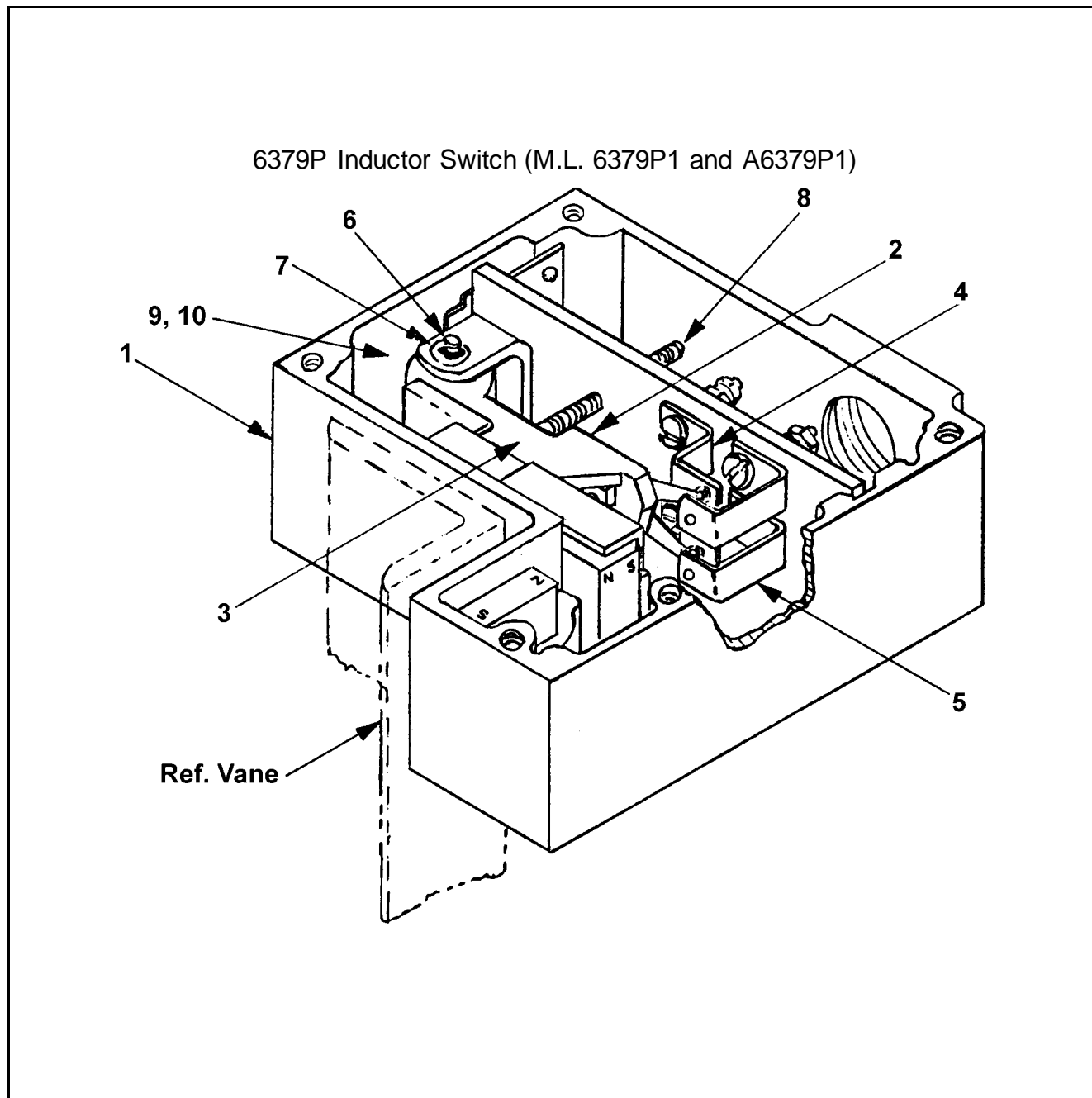

Unpublished Work—©Otis Elevator Co.; 2006

# OTIS

**Safety First!**

**SERVICE ENGINEERING**

**Otis Elevator Company**

**Bloomfield, Connecticut USA**

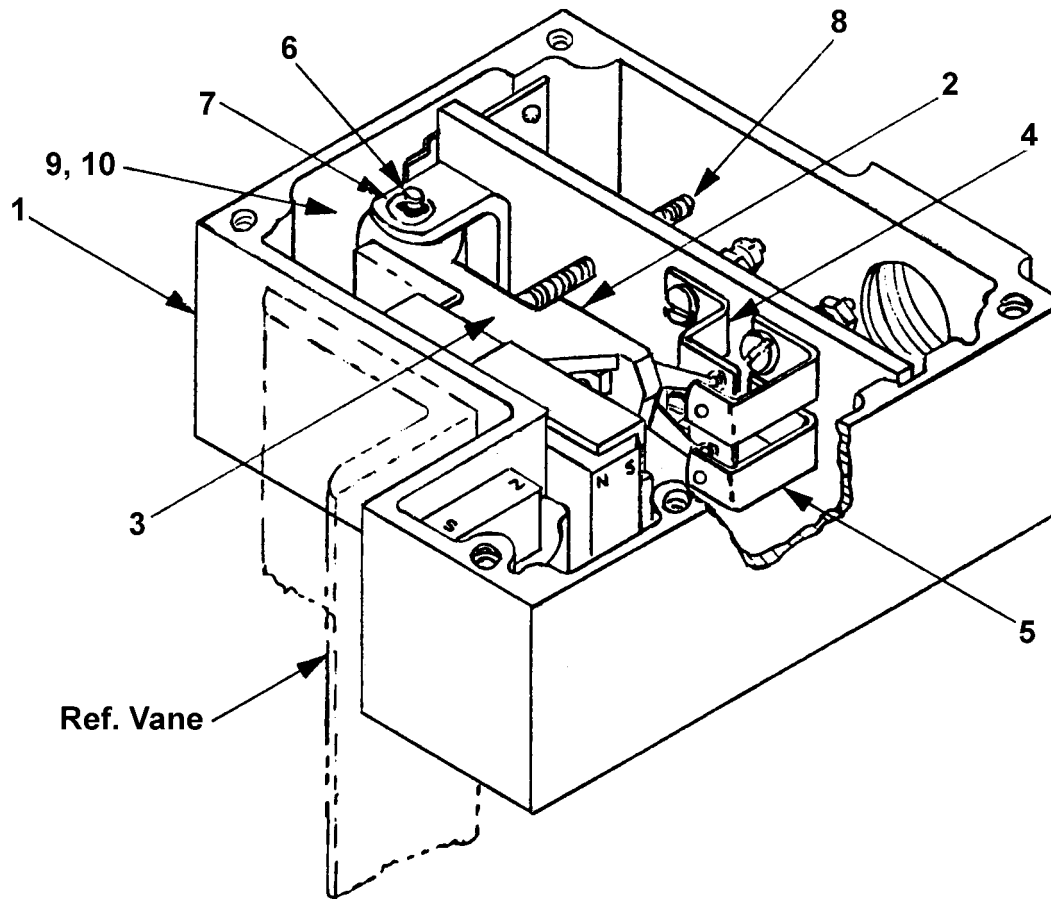

REF No.	PART No.	QTY USED	DESCRIPTION
1	GS-A308FD3 A6379P1	1	Box, Aluminum, Complete with Stationary Magnet
2	2700BF1	1	Contact Assembly., Complete with Movable Magnet
---	346AEV2	1	Cover, See <b>NOTE 1</b>
3	353BE1	1	Disc, Felt
4	179CD2	2	Holder, Contact, Stationary Breaking
5	179CE2	2	Holder, Contact, Stationary Making
6	77NM3	1	Pin (for Contact Base and Panel Assemblies)
7	---	2	Ring, Retaining (for Pin)
8	124CP1	1	Screw, 10-32" x 1-1/2" Length
9	128AF50	4	Washer, Special, Brass, See <b>NOTE 2</b>
10	---	2	Washer, No. 10 Brass, See <b>NOTE 2</b>

**NOTE 1:** Not illustrated.

**NOTE 2:** General location; parts not shown.