

C-3077 - GAL DOOR OPERATOR, TYPE: "MODL"

December, 1983

Page 1

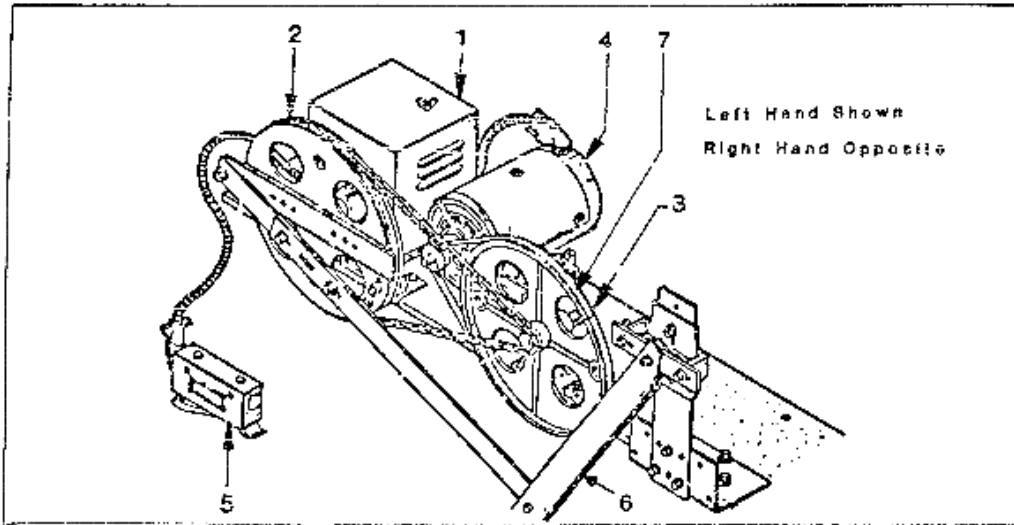

REF NO.	PART NO.	QTY	DESCRIPTION
1		1	MOD Operator Limit Control with
		1	MOD Limit Switch
		4	Bridging Cam Assemblies
		8	Activating Cam Set
		1	Resistor Assembly
		2	Resistors, 300 OHMS. 100W
	2		1
		1	Chain and U-Bolts
		1	Rubber Suppressor
		1	Bearing and Bearing Block
		1	MODL Stop Roller & Bracket
3			1
		1	Intermediate Bearing Block
		1	Adjusting Stud
		1	Adjusting Angle & Bolt
		1	Chain Sprocket, No. 35 w/15 Teeth
4	VP-782008	1	Motor, 1/6 HP 220 VDC, 1140 RPM
5	VP-782017	1	GAL Type 'G' Contact (LRV Systems)
5	6098E5	1	Mechanical Gate Switch Left Hand or Center Open (MRV Systems)
5	6098E6	1	Mechanical Switch, Right Hand (MRV Systems)
6		1	'L' Operator Door Drive Arm Assy.
RECOMMENDED SPARE PART 7	VP-782009	1	'V' Belt, 4L 440

NOTE: If no Part Number Listed, Give Part Description